

# APPROVAL SHEET

## WW25A

$\pm 1\%$ ,  $\pm 5\%$ , 3W

Ultra low ohm power chip resistors

Size 2512 (6432)

Metal Current Sensing Type

RoHS Exemption free and Lead free products

Halogen free

\*Contents in this sheet are subject to change without prior notice.

## FEATURE

1. Ultra low and stable TCR performance
2. High power rating and compact size
3. High reliability and stability
4. Reduced size of final equipment
5. RoHS exemption free and Lead free.
6. Inductance below 1nH

## APPLICATION

- Power supply
- PDA
- Digital meter
- Computer
- Automotives
- Battery charger
- DC-DC power converter

## DESCRIPTION

The resistors are constructed in a high grade low resistive metal body. The resistive layer is covered with a protective coat and printed a resistance marking code over it. Finally, the two external end terminations are added. For ease of soldering the outer layer of these end terminations is a tin (lead-free) alloy.

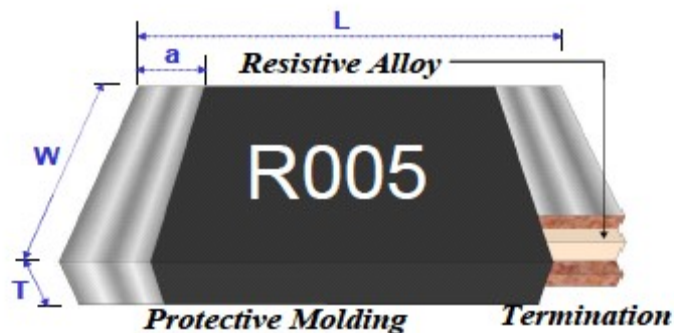

Item	Protective Molding	Resistive Element	Internal Terminal	External Terminal
Material	Resin	Alloy Metal	Copper	Solder

Fig 1. Construction of Chip-R

**QUICK REFERENCE DATA**

Item	General Specification	
Series No.	WW25A	
Size code	2512 ( 6432 )	
Resistance Tolerance	±5%, ±1%	
Resistance Value	0.0005Ω, 0.00075Ω, 0.001Ω, 0.002Ω, 0.003Ω, 0.004Ω 0.005Ω, 0.006Ω, 0.007Ω,, 0.008Ω, 0.009Ω, 0.010Ω	0.012Ω, 0.014Ω, 0.015Ω, 0.016Ω, 0.018Ω, 0.020Ω, 0.025Ω, 0.030Ω, 0.033Ω, 0.035Ω, 0.040Ω, 0.050Ω, 0.060Ω, 0.075Ω, 0.080Ω, 0.100Ω
TCR (ppm/°C) +25 ~ +155°C	≤ ±70 ppm/°C	≤ ±50 ppm/°C
Max. dissipation at T <sub>amb</sub> =70°C	3 W	
Operation temperature	-55 ~ +170°C	

Note :

- Resistance value will be changed by soldering condition and design of soldering pad, please design products in consideration of this change of resistance value.

**MECHANICAL DATA**

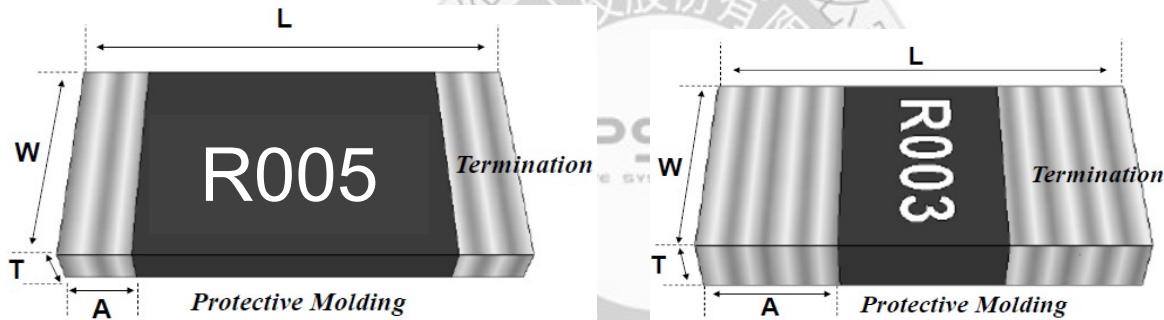

Unit : mm

WW25A	L	W	T	A
2512 3W 4~100mΩ	6.20±0.20	3.25±0.20	0.65±0.20	0.80±0.20
2512 3W 2~3 mΩ	6.40±0.20	3.25±0.20	0.75±0.20	2.00±0.20
2512 3W 1mΩ	6.40±0.20	3.25±0.20	0.80±0.20	2.00±0.20
2512 3W 0.5~0.75mΩ	6.30±0.20	3.25±0.20	0.80±0.20	2.25±0.20



**FOOT PRINT**

Type	W	D	L
2512 3W 4m~100mΩ	3.70	1.60	7.60
2512 3W 0.5~3 mΩ	4.00	3.00	7.30



## MARKING

Each resistor is marked with a three or four-digit code on the protective coating to designate the nominal resistance value.

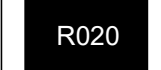
PN	Resistance	Marking digit	Marking
R0L5	0.5 mΩ	three -digit	
0L75	0.75 mΩ	three -digit	
R005	5 mΩ	four -digit	
R020	20 mΩ	four -digit	

## FUNCTIONAL DESCRIPTION

### Derating curve

The power that the resistor can dissipate depends on the operating temperature; see Fig.2

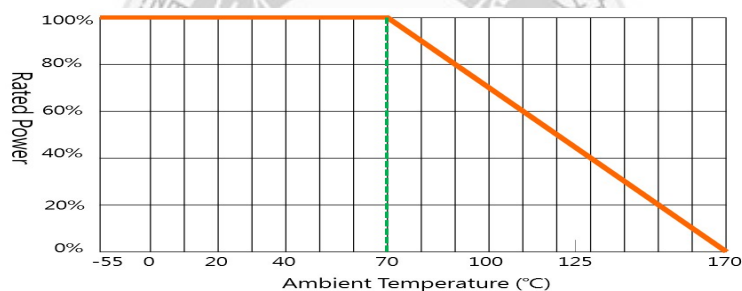

## MOUNTING

Due to their rectangular shapes and small tolerances, Surface Mountable Resistors are suitable for handling by automatic placement systems.

Chip placement can be on ceramic substrates and printed-circuit boards (PCBs).

Electrical connection to the circuit is by individual soldering condition.

The end terminations guarantee a reliable contact.

## SOLDERING CONDITION

The robust construction of chip resistors allows them to be completely immersed in a solder bath of 260°C for 10 seconds. Therefore, it is possible to mount Surface Mount Resistors on one side of a PCB and other discrete components on the reverse (mixed PCBs).

Surface Mount Resistors are tested for solderability at 235°C during 2 seconds. The test condition for no leaching is 260°C for 30 seconds. Typical examples of soldering processes that provide reliable joints without any damage are given in Fig 3.

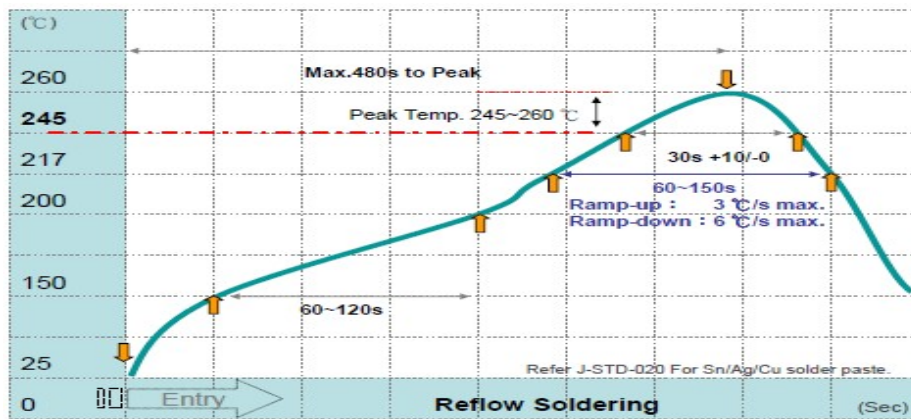

Fig 3. Infrared soldering profile for Chip Resistors WW25A

## CATALOGUE NUMBERS

The resistors have a catalogue number starting with .

WW25	A	R005	J	T	L
<b>Size code</b> WW25 : 2512	<b>Type code</b> A : 3W Sensing type	<b>Resistance code</b> R is first digit followed by 3 significant digits. 0.010Ω = R010 0.005Ω = R005 0.5mΩ = R0L5 0.75mΩ = 0L75	<b>Tolerance</b> J : ±5% F : ±1%	<b>Packaging code</b> T : 7" reeled in tape	<b>Termination code</b> L = Sn base (lead free)

Reeled tape packaging : 12mm width plastic emboss taping 4,000pcs per reel.

## TEST AND REQUIREMENTS(JIS C 5201-1 : 1998)

Essentially all tests are carried out according to the schedule of IEC publication 115-8, category **LCT/UCT/56**(rated temperature range : Lower Category Temperature, Upper Category Temperature; damp heat, long term, 56 days). The testing also meets the requirements specified by EIA, EIAJ and JIS.

The tests are carried out in accordance with IEC publication 68, "Recommended basic climatic and mechanical robustness testing procedure for electronic components" and under standard atmospheric conditions according to IEC 60068-1, subclause 5.3. Unless otherwise specified, the following value supplied :

Temperature: 15°C to 35°C.

Relative humidity: 45% to 75%.

Air pressure: 86kPa to 106 kPa (860 mbar to 1060 mbar).

All soldering tests are performed with mildly activated flux.

TEST	PROCEDURE	REQUIREMENT
Temperature Coefficient of Resistance(T.C.R) <b>Clause 4.8</b>	Natural resistance change per change in degree centigrade. $\frac{R_2 - R_1}{R_1(t_2 - t_1)} \times 10^6 \text{ (ppm/}^\circ\text{C)}$ $t_1 : 20^\circ\text{C}+5^\circ\text{C}-1^\circ\text{C}$ $R_1$ : Resistance at reference temperature $R_2$ : Resistance at test temperature $+155^\circ\text{C}$	Refer to "QUICK REFERENCE DATA"
Short time overload (S.T.O.L) <b>Clause 4.13</b>	Permanent resistance change after a 5second application of 5 times rated power	no visible damage $\Delta R/R$ max. $\pm(1\%+0.5\text{m}\Omega)$
Resistance to soldering heat(R.S.H) <b>Clause 4.18</b>	Un-mounted chips completely immersed for $10\pm 1$ second in a SAC solder bath at $260^\circ\text{C}\pm 5^\circ\text{C}$	no visible damage $\Delta R/R$ max. $\pm(0.5\%+0.5\text{m}\Omega)$
Solderability <b>Clause 4.17</b>	Un-mounted chips completely immersed for $3\pm 0.5$ second in a SAC solder bath at $235^\circ\text{C}\pm 5^\circ\text{C}$	good tinning (>95% covered) no visible damage
Temperature cycling <b>Clause 4.19</b>	30 minutes at $-55^\circ\text{C}\pm 3^\circ\text{C}$ , 2~3 minutes at $20^\circ\text{C}+5^\circ\text{C}-1^\circ\text{C}$ , 30 minutes at $+155^\circ\text{C}\pm 3^\circ\text{C}$ , 2~3 minutes at $20^\circ\text{C}+5^\circ\text{C}-1^\circ\text{C}$ , total 5 continuous cycles	no visible damage $\Delta R/R$ max. $\pm(0.5\%+0.5\text{m}\Omega)$
Load life (endurance) <b>Clause 4.25</b>	1000 $+48/-0$ hours, loaded with RCWV or $V_{\text{max}}$ in chamber controller $70\pm 2^\circ\text{C}$ , 1.5 hours on and 0.5 hours off	no visible damage $\Delta R/R$ max. $\pm(1\%+0.5\text{m}\Omega)$
Load life in Humidity <b>Clause 4.24</b>	1000 $+48/-0$ hours, loaded with RCWV or $V_{\text{max}}$ in humidity chamber controller at $40^\circ\text{C}\pm 2^\circ\text{C}$ and 90~95% relative humidity, 1.5hours on and 0.5 hours off	no visible damage $\Delta R/R$ max. $\pm(1\%+0.5\text{m}\Omega)$
Adhesion <b>Clause 4.32</b>	Pressurizing force: 5N, Test time: $10\pm 1$ sec.	No remarkable damage or removal of the terminations
Bending strength	Bending 2mm on 90mm FR4 PCB	no visible damage $\Delta R/R$ max. $\pm(0.5\%+0.5\text{m}\Omega)$

## PACKAGING

Plastic Tape specifications (unit :mm)

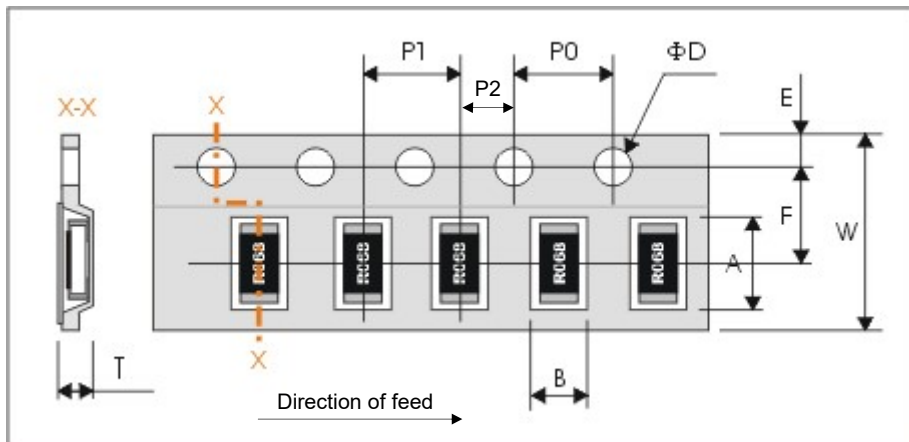

Symbol	A	B	W	F	E
Dimensions	6.75±0.20	3.50±0.20	12.00±0.30	5.50±0.1	1.75±0.10

Symbol	P1	P0	P2	ΦD	T
Dimensions	4.00±0.10	4.00±0.10	2.00±0.10	Φ1.50 ±0.10	Max. 1.2

## Reel dimensions

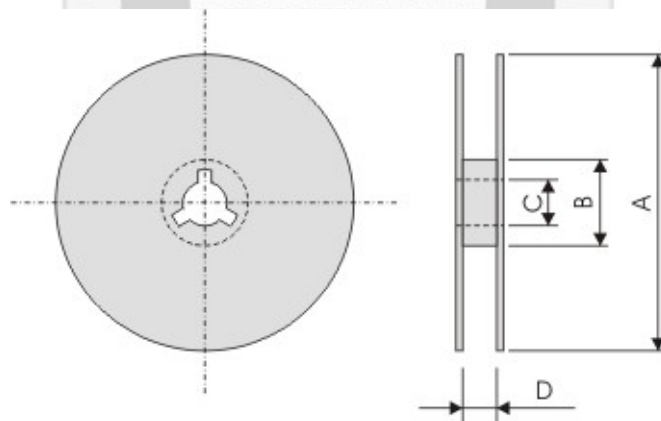

Symbol	A	B	C	D
(unit : mm)	Φ178.0±2.0	Φ60.0±1.0	13.0±0.2	14.0±0.2

## Taping quantity

- Chip resistors 4,000 pcs per reel.

单击下面可查看定价，库存，交付和生命周期等信息

[>>Walsin Technology\(华新科技\)](#)