

# APPROVAL SHEET

## WW25R

$\pm 1\%$ ,  $\pm 5\%$ , **2W**

Metal Plate Low Ohm Power Chip Resistors

Size 2512 (6432)

RoHS Exemption free and Lead free products

Halogen free

Current Sensing Type



\*Contents in this sheet are subject to change without prior notice.

## FEATURE

1. Ultra low and stable TCR performance
2. High power rating and compact size
3. High reliability and stability
4. Reduced size of final equipment
5. RoHS exemption free and Lead free product
6. Low inductance below 3nH

## APPLICATION

- Power supply
- PDA
- Digital meter
- Computer
- Automotives
- Battery charger
- DC-DC power converter

## DESCRIPTION

The resistors are constructed in a **high grade low resistive metal body**. The resistive layer is covered with a protective coat and printed a resistance marking code over it. Finally, the two external end terminations are added. For ease of soldering the outer layer of these end terminations is a Lead-free terminations.



Fig 1. Construction of Chip-R

### QUICK REFERENCE DATA

Item	General Specification
Series No.	WW25R
Size code	2512 ( 6432 )
Resistance Tolerance	±5%, ±1%
Resistance Value	0.001Ω, 0.002Ω, 0.003Ω, 0.004Ω, 0.005Ω, 0.006Ω, 0.007Ω, 0.008Ω, 0.009Ω, 0.010Ω
TCR (ppm/°C)	≤ ±75 ppm/°C
Max. dissipation at T <sub>amb</sub> =70°C	2 W
Max. Operation Current (DC or RMS)	44.7A, 31.6A, 25.8A, 22.3A, 20A, 18.2A, 16.9A, 15.8A, 14.9A, 14.1A
Operation temperature	-55 ~ +155°C

Note :

1. Max. Operation Current : So called RCWC (Rated Continuous Working Current) is determined by

$$RCWC = \sqrt{\text{Rated Power} / \text{Resistance Value}}$$

### MECHANICAL DATA

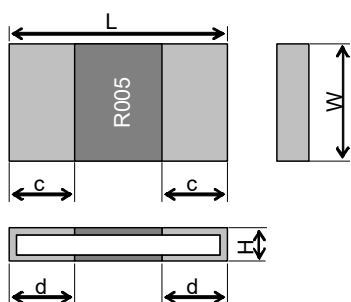

Type	Size(inch)	Resistance	L(mm)	W(mm)	H(mm)	c(mm)	d(mm)	
WW25R	2512	1mΩ	6.3±0.25	3.2±0.25	0.38±0.15	2.2±0.25		
		2mΩ			0.58±0.15			
		3mΩ			0.45±0.15			
		4mΩ			0.34±0.15			
		5mΩ		3.1±0.25	0.51±0.15			1.1±0.25
		6mΩ			0.5±0.15			1.1±0.25
		7mΩ			0.5±0.15			0.6±0.25
		8mΩ			0.35±0.15			1.1±0.25
		9mΩ			0.35±0.15			0.8±0.25
		10mΩ			0.35±0.15			0.5±0.25

## MARKING

Each resistor is marked with a four-digit code on the protective coating to designate the nominal resistance value.

R005 = 5 m $\Omega$

R001 = 1 m $\Omega$

## FUNCTIONAL DESCRIPTION

### Derating curve

The power that the resistor can dissipate depends on the operating temperature; see Fig.2

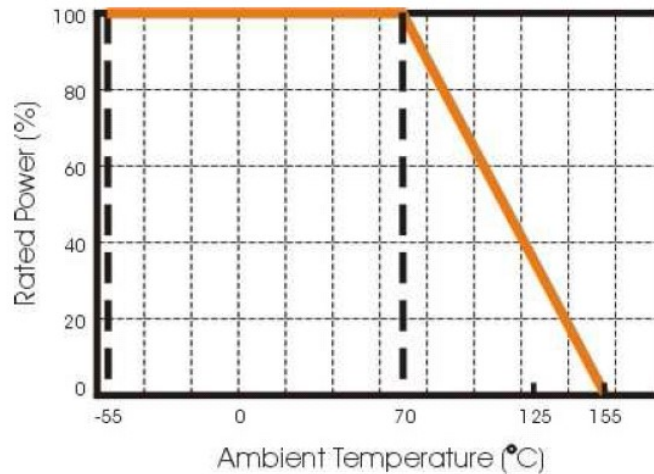

Fig.2 Maximum dissipation in percentage of rated power  
As a function of the ambient temperature

## MOUNTING

Due to their rectangular shapes and small tolerances, Surface Mountable Resistors are suitable for handling by automatic placement systems.

Chip placement can be on ceramic substrates and printed-circuit boards (PCBs).

Electrical connection to the circuit is by individual soldering condition.

The end terminations guarantee a reliable contact.

## SOLDERING CONDITION

The robust construction of chip resistors allows them to be completely immersed in a solder bath of 260°C for 10 seconds. Therefore, it is possible to mount Surface Mount Resistors on one side of a PCB and other discrete components on the reverse (mixed PCBs).

Surface Mount Resistors are tested for solderability at 235°C during 3 seconds. The test condition for no leaching is 260°C for 30 seconds. Typical examples of soldering processes that provide reliable joints without any damage are given in Fig 3.

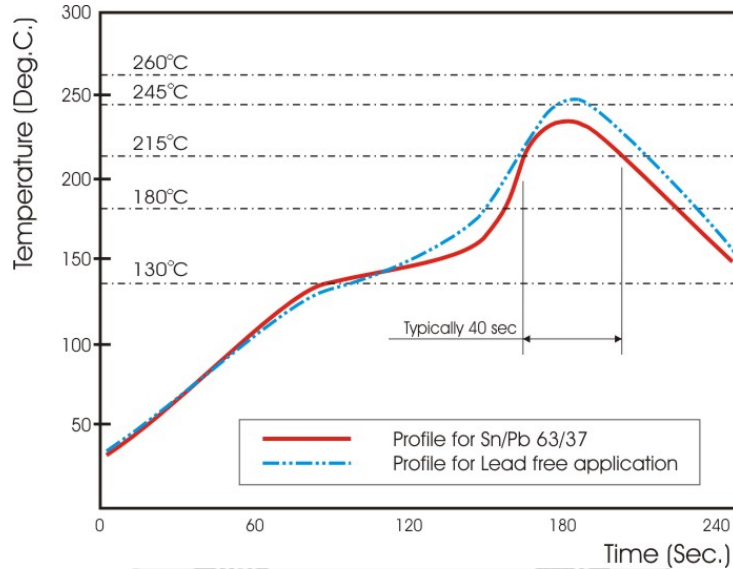

Fig 3. Infrared soldering profile for Chip Resistors WW25

## CATALOGUE NUMBERS

The resistors have a catalogue number starting with .

WW25	R	R001	F	T	L
<b>Size code</b> WW25 : 2512	<b>Type code</b> R : 2W Sensing type	<b>Resistance code</b> R is first digit followed by 3 significant digits. 0.001Ω = R001 0.005Ω = R005 0.010Ω = R010	<b>Tolerance</b> J : ±5% F : ±1%	<b>Packaging code</b> T : 7" reel in tape	<b>Termination code</b> L = Sn base (lead free)

Reeled tape packaging : 12mm width plastic emboss taping 4,000pcs per reel.

### TEST AND REQUIREMENTS(JIS C 5201-1 : 1998)

Essentially all tests are carried out according to the schedule of IEC publication 115-8, category LCT/UCT/56(rated temperature range : Lower Category Temperature, Upper Category Temperature; damp heat, long term, 56 days). The testing also meets the requirements specified by EIA, EIAJ and JIS.

The tests are carried out in accordance with IEC publication 68, "Recommended basic climatic and mechanical robustness testing procedure for electronic components" and under standard atmospheric conditions according to IEC 60068-1, subclause 5.3. Unless otherwise specified, the following value supplied :

Temperature: 15°C to 35°C.

Relative humidity: 45% to 75%.

Air pressure: 86kPa to 106 kPa (860 mbar to 1060 mbar).

All soldering tests are performed with mildly activated flux.

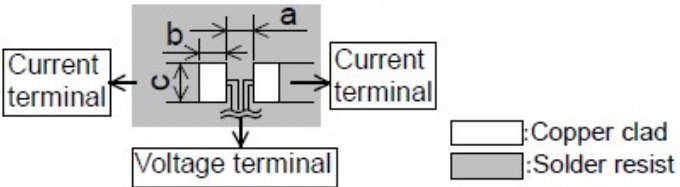
TEST	PROCEDURE	REQUIREMENT													
Dimension Resistance <b>Clause 4.4.2</b>	<p>Resistance value shall be measured by mounting the substrate of the following condition.</p>  <p style="text-align: right;">Unit:mm</p> <table border="1"> <thead> <tr> <th>Style</th> <th>Resistance value(mΩ)</th> <th>a</th> <th>b</th> <th>c</th> </tr> </thead> <tbody> <tr> <td rowspan="2">WW25R</td> <td>2 to 4</td> <td>1.8</td> <td>2.9</td> <td rowspan="2">3.5</td> </tr> <tr> <td>5 to 10</td> <td>4.0</td> <td>1.8</td> </tr> </tbody> </table> <p>Thickness of copper clad: 0.035mm                      4-Terminal method                      Measurement current: 1(A)                      Note: The measuring apparatus corresponding to DC Low-ohm Meter (1A) of AX-1152D for ADEX CORPORATION.</p>	Style	Resistance value(mΩ)	a	b	c	WW25R	2 to 4	1.8	2.9	3.5	5 to 10	4.0	1.8	The resistance should be within specified tolerance per resistance value!
Style	Resistance value(mΩ)	a	b	c											
WW25R	2 to 4	1.8	2.9	3.5											
	5 to 10	4.0	1.8												
Temperature Coefficient of Resistance(T.C.R) <b>Clause 4.8</b>	Natural resistance change per change in degree centigrade. $\frac{R_2 - R_1}{R_1(t_2 - t_1)} \times 10^6 \text{ (ppm/}^\circ\text{C)}$ t <sub>1</sub> : 20°C+5°C-1°C R <sub>1</sub> : Resistance at reference temperature R <sub>2</sub> : Resistance at test temperature	Refer to "QUICK REFERENCE DATA"													
Short time overload (S.T.O.L) <b>Clause 4.13</b>	Permanent resistance change after a 2 second application of a voltage 2.5 times RCWC or the maximum operation current specified in the above list, whichever is less.	no visible damage ΔR/R max. ±(1%+0.0001Ω)													
Resistance to soldering heat(R.S.H) <b>IEC 60068-2-58: 2004</b>	Un-mounted chips completely immersed for 10±0.5 second in a SAC solder bath at 260°C±5°C	no visible damage ΔR/R max. ±(1%+0.0001Ω)													

Solderability <b>IEC 60068-2-58: 2004</b>	Un-mounted chips completely immersed for $2 \pm 0.5$ second in a SAC solder bath at $235^{\circ}\text{C} \pm 5^{\circ}\text{C}$	good tinning (>95% covered) no visible damage
Temperature cycling <b>Clause 4.19</b>	30 minutes at $-55^{\circ}\text{C} \pm 3^{\circ}\text{C}$ , 2~3 minutes at $20^{\circ}\text{C} + 5^{\circ}\text{C} - 1^{\circ}\text{C}$ , 30 minutes at $+155^{\circ}\text{C} \pm 3^{\circ}\text{C}$ , 2~3 minutes at $20^{\circ}\text{C} + 5^{\circ}\text{C} - 1^{\circ}\text{C}$ , total 5 continuous cycles	no visible damage $\Delta R/R$ max. $\pm(1\% + 0.0001\Omega)$
Load life (endurance) <b>Clause 4.25</b>	1000 +48/-0 hours, loaded with RCWC or max. operation current in chamber controller $70 \pm 2^{\circ}\text{C}$ , 1.5 hours on and 0.5 hours off	no visible damage $\Delta R/R$ max. $\pm(5\% + 0.0001\Omega)$
Endurance at upper temperature	1000 +48/-0 hours, no load at $155 \pm 2^{\circ}\text{C}$ ,	no visible damage $\Delta R/R$ max. $\pm(5\% + 0.0001\Omega)$
Load life in Humidity <b>Clause 4.24</b>	1000 +48/-0 hours, no loaded at $40^{\circ}\text{C} \pm 2^{\circ}\text{C}$ and 90~95% relative humidity.	no visible damage $\Delta R/R$ max. $\pm(5\% + 0.0001\Omega)$
Adhesion <b>Clause 4.32</b>	Pressurizing force: 5N, Test time: $10 \pm 1$ sec.	No remarkable damage or removal of the terminations



## PACKAGING

Plastic Tape specifications (unit :mm)

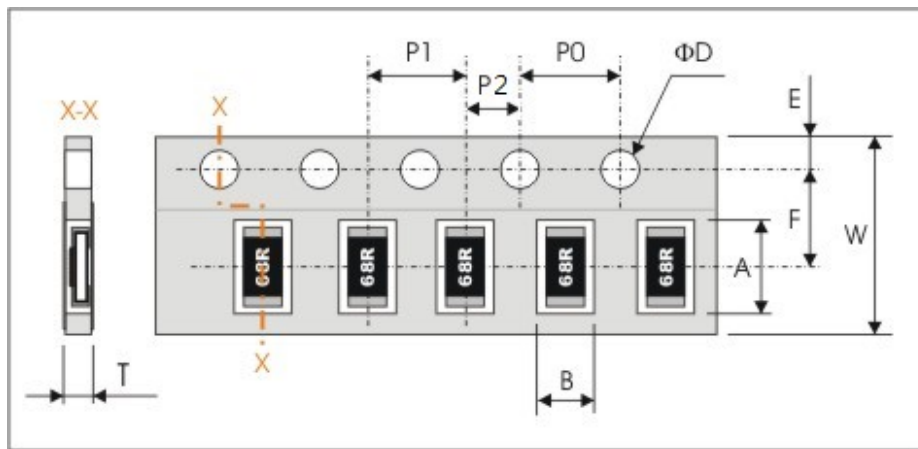

Symbol	A	B	W	F	E
Dimensions	6.75±0.20	3.50±0.20	12.00±0.30	5.50±0.10	1.75±0.10

Symbol	P1	P0	P2	ΦD	T
Dimensions	4.00±0.10	4.00±0.10	2.00±0.10	Φ1.50 <sup>+0.1</sup> <sub>-0.0</sub>	0.90±0.20

## Reel dimensions

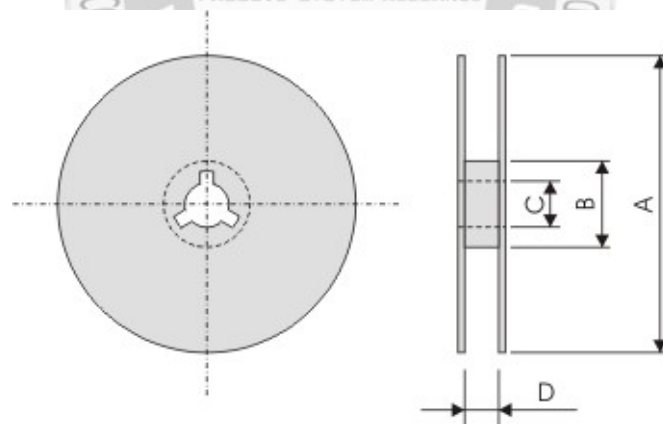

Symbol	A	B	C	D
(unit : mm)	Φ180.0 -1.5	Φ60.0±1.0	13.0±0.2	13.0±1.0

## Taping quantity

- Chip resistors 4,000 pcs per reel.



单击下面可查看定价，库存，交付和生命周期等信息

[>>Walsin Technology\(华新科技\)](#)