

# APPROVAL SHEET

**MF04P, MF06P, MF08P, MF12P, MF10P,  
MF20P, MF25P**

**±1%, ±5% 1Ω~1MΩ**

Thick film High Power Chip Resistors

Size 0402, 0603, 0805, 1206, 1210, 2010, 2512

Automotive Grade & Anti-sulfur

RoHS 2 Compliant with exemption 7C-I

Halogen free

\*Contents in this sheet are subject to change without prior notice.

## FEATURE

1. Automotive grade AEC Q-200 compliant
2. High reliability 1% stability
3. 100% CCD inspection
4. RoHS 2 Compliant with exemption 7C-I and Halogen free products
5. High power rating up to 2W
6. Anti-sulfur ASTM B-809  $50\pm 2^{\circ}\text{C}$ , 1000hrs

## APPLICATION

1. High accuracy dc-power supply
2. Digital multi-meter
3. Telecommunication
4. Computer
5. Automotive industry
6. Medical and military equipment

## DESCRIPTION

The resistors are constructed in a high grade ceramic body (aluminum oxide). Internal metal electrodes are added at each end and connected by a resistive paste that is applied to the top surface of the substrate. The composition of the paste is adjusted to give the approximate resistance required and the value is trimmed to nominated value within tolerance which controlled by laser trimming of this resistive layer.

The resistive layer is covered with a protective coat. Finally, the two external end terminations are added. For ease of soldering the outer layer of these end terminations is a Tin (lead free) alloy.

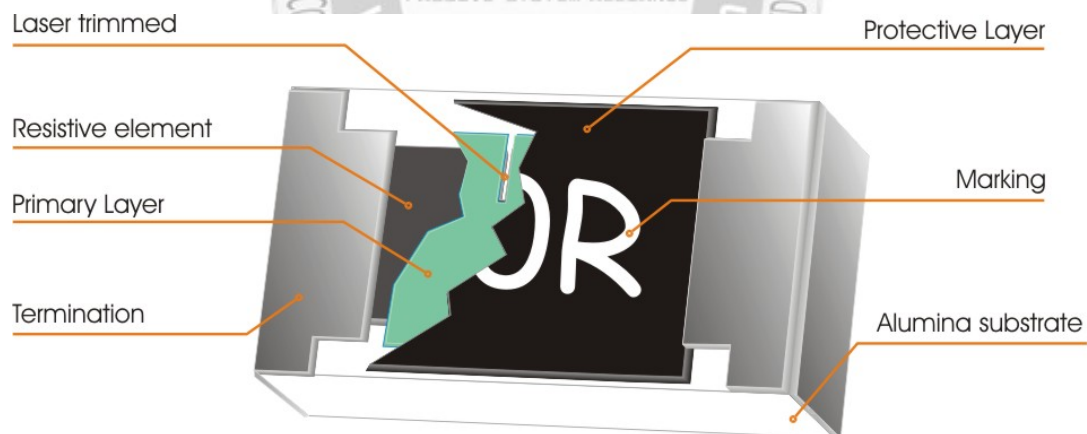

Fig 1. Construction of Chip-R

### QUICK REFERENCE DATA

Type	Size	Power Rating at 70°C	Max. RCWV	Max. Overload Voltage	Resistance Tolerance	Temperature Coefficient (ppm/°C)	Resistance Range		Standard Resistance Values
							Min.	Max.	
MF04P	0402	1/8W	50V	100V	±1%(F)	±100ppm	10Ω	1MΩ	E96/E24
					±1%(F)	-200/+400ppm	1Ω	9.76Ω	E96/E24
					±5%(J)	±200ppm	10Ω	1MΩ	E24
					±5%(J)	-200/+400ppm	1Ω	9.76Ω	E24
MF06P	0603	1/8W	50V	100V	±1%(F)	±100ppm	10Ω	1MΩ	E96/E24
					±1%(F)	±200ppm	1Ω	9.76Ω	E96/E24
					±5%(J)	±200ppm	1Ω	1MΩ	E24
MF08P	0805	1/4W	150V	300V	±1%(F)	±100ppm	10Ω	1MΩ	E96/E24
					±1%(F)	±150ppm	1Ω	9.76Ω	E96/E24
					±5%(J)	±200ppm	1Ω	1MΩ	E24
MF12P	1206	1/2W	200V	300V	±1%(F)	±100ppm	1Ω	1MΩ	E96/E24
					±5%(J)	±200ppm	1Ω	1MΩ	E24
MF10P	1210	1/2W	200V	400V	±1%(F)	±100ppm	1Ω	1MΩ	E96/E24
					±5%(J)	±200ppm	1Ω	1MΩ	E24
MF20P	2010	1W	200V	400V	±1%(F)	±100ppm	1Ω	1MΩ	E96/E24
					±5%(J)	±200ppm	1Ω	1MΩ	E24
MF25P	2512	2W	300V	600V	±1%(F)	±100ppm	1Ω	1MΩ	E96/E24
					±5%(J)	±200ppm	1Ω	1MΩ	E24

Type	Size	Description	Max Rate Current	Resistance
MF04P	0402	Zero Ohm , Jumper	≤ 1.5A	< 50 mΩ
MF06P	0603	Zero Ohm , Jumper	≤ 2A	< 20 mΩ
MF08P	0805	Zero Ohm , Jumper	≤ 4A	< 20 mΩ
MF12P	1206	Zero Ohm , Jumper	≤ 4A	< 20 mΩ
MF10P	1210	Zero Ohm , Jumper	≤ 4A	< 20 mΩ
MF20P	2010	Zero Ohm , Jumper	≤ 6A	< 20 mΩ
MF25P	2512	Zero Ohm , Jumper	≤ 6A	< 20 mΩ

Note :  $RCWV = (P \times R)^{1/2}$  or Max. RCWV listed above, whichever is lower.

RCWV : Working Voltage(V), P: Rated Power (W), R: Resistance Value (Ω)

**DIMENSIONS (unit: mm)**

Symbol	MF04P	MF06P	MF08P	MF12P	MF10P	MF20P	MF25P
L	1.00 ± 0.05	1.60 ± 0.10	2.00 ± 0.10	3.10 ± 0.10	3.10 ± 0.10	5.00 ± 0.20	6.30 ± 0.20
W	0.50 ± 0.05	0.80 ± 0.10	1.25 ± 0.10	1.60 ± 0.10	2.60 ± 0.10	2.50 ± 0.20	3.10 ± 0.20
T	0.35 ± 0.05	0.45 ± 0.10	0.50 ± 0.15	0.55 ± 0.10	0.55 ± 0.10	0.60 ± 0.10	0.60 ± 0.15
Tt	0.25 ± 0.10	0.30 ± 0.20	0.40 ± 0.20	0.50 ± 0.25	0.50 ± 0.20	0.65 ± 0.25	0.60 ± 0.25
Tb	0.20 ± 0.10	0.30 ± 0.20	0.40 ± 0.20	0.50 ± 0.25	0.50 ± 0.20	0.60 ± 0.25	1.80 ± 0.25

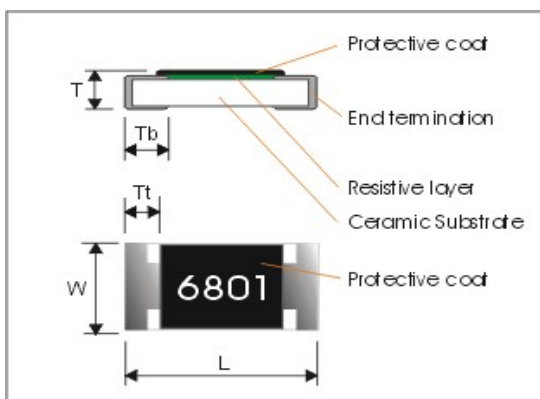

## MARKING

Size \ Nr. Of digit of code \ Tolerance	±5%	±1%
2512 (6432)	3-digits marking	4-digits marking
2010 (5025)	3-digits marking	4-digits marking
1210 (3225)	3-digits marking	4-digits marking
1206 (3216)	3-digits marking	4-digits marking
0805 (2012)	3-digits marking	4-digits marking
0603 (1608)	3-digits marking	3-digits marking

**0402 has no marking.**

**3-digits marking** ( ±1% : 0603 )

Nominal resistance	Description
1.E-24 series	As 0603 WR06X ±5%.
2.E-96 series	The 1st two digit codes are referring to the CODE on the table, the 3rd code is the index of resistance value : Y=10 <sup>-2</sup> , X=10 <sup>-1</sup> , A=10 <sup>0</sup> , B=10 <sup>1</sup> , C=10 <sup>2</sup> , D=10 <sup>3</sup> , E=10 <sup>4</sup> , F=10 <sup>5</sup> EX : 17.8Ω=25X, 178Ω=25A, 1K78 =25B 17K8=25C, 178K=25D, 1M78=25E
3. Remark	There is no marking for the items are not under E-24 and E-96 series

CODE	R_value	CODE	R_value	CODE	R_value	CODE	R_value	CODE	R_value	CODE	R_value	CODE	R_value	CODE	R_value
01	100	13	133	25	178	37	237	49	316	61	422	73	562	85	750
02	102	14	137	26	182	38	243	50	324	62	432	74	576	86	768
03	105	15	140	27	187	39	249	51	332	63	442	75	590	87	787
04	107	16	143	28	191	40	255	52	340	64	453	76	604	88	806
05	110	17	147	29	196	41	261	53	348	65	464	77	619	89	825
06	113	18	150	30	200	42	267	54	357	66	475	78	634	90	845
07	115	19	154	31	205	43	274	55	365	67	487	79	649	91	866
08	118	20	158	32	210	44	280	56	374	68	499	80	665	92	887
09	121	21	162	33	215	45	287	57	383	69	511	81	681	93	909
10	124	22	165	34	221	46	294	58	392	70	523	82	698	94	931
11	127	23	169	35	226	47	301	59	402	71	536	83	715	95	953
12	130	24	174	36	232	48	309	60	412	72	549	84	732	96	976

**4-digits marking** ( ±1% : 2512/ 2010/ 1210/ 1206/ 0805 )

Each resistor is marked with a four digits code on the protective coating to designate the nominal resistance value.

### Example

RESISTANCE	10Ω	12Ω	100Ω	6800Ω	47000Ω
3-digits marking ( 1206 & 0805 & 0603 ±5% )	100	120	101	682	473
4-digits marking	10R0	12R0	1000	6801	4702

## FUNCTIONAL DESCRIPTION

### Product characterization

Standard values of nominal resistance are taken from the E96&E24 series for resistors with a tolerance of  $\pm 1\%$ ,  $\pm 5\%$ . The values of the E96/E24 series are in accordance with "IEC publication 60063".

### Derating

The power that the resistor can dissipate depends on the operating temperature; see Fig.2

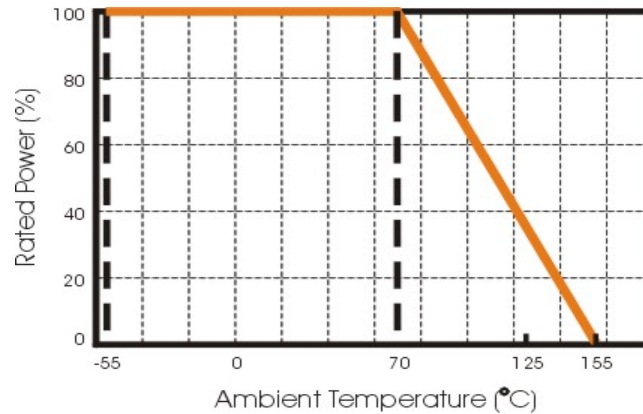

Fig.2 Maximum dissipation in percentage of rated power  
As a function of the ambient temperature

## MOUNTING

Due to their rectangular shapes and small tolerances, Surface Mountable Resistors are suitable for handling by automatic placement systems.

Chip placement can be on ceramic substrates and printed-circuit boards (PCBs).

Electrical connection to the circuit is by individual soldering condition.

The end terminations guarantee a reliable contact.

## SOLDERING CONDITION

The robust construction of chip resistors allows them to be completely immersed in a solder bath of 260°C for 10 seconds. Therefore, it is possible to mount Surface Mount Resistors on one side of a PCB and other discrete components on the reverse (mixed PCBs).

Surface Mount Resistors are tested for solderability at 235°C during 2 seconds. The test condition for no leaching is 260°C for 30 seconds. Typical examples of soldering processes that provide reliable joints without any damage are given in Fig 3.

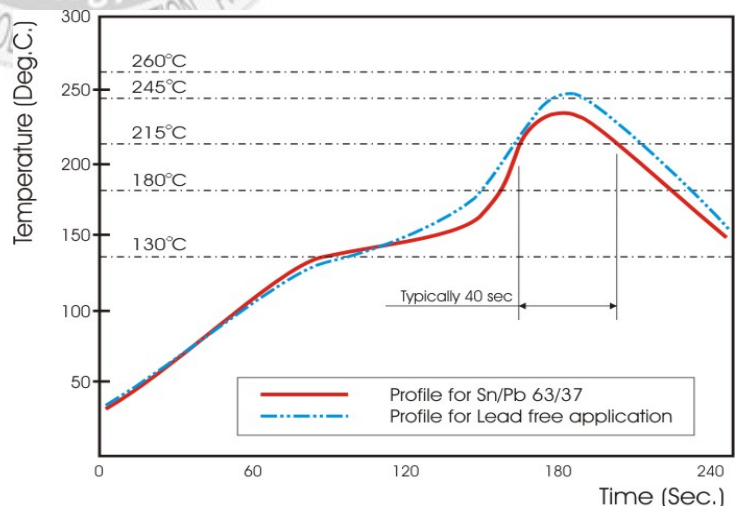

Fig 3. Infrared soldering profile for Chip Resistors

## CATALOGUE NUMBERS

The resistors have a catalogue number starting with:

MF06	P	1002	F	T	L
<b>Size code</b>	<b>Type code</b>	<b>Resistance code</b>	<b>Tolerance</b>	<b>Packaging code</b>	<b>Termination code</b>
MF04: 0402	P :Power	5%, E24:	J : ±5%	T: 7" Reeled taping .	L = Sn base (lead free)
MF06: 0603	0402 size = 1/8W	2 significant digits followed by No. of zeros and a blank	F : ±1%		
MF08: 0805	0603 size = 1/8W	e.g.:	P : Jumper		
MF12: 1206	0805 size = 1/4W	3ohm =3R0_			
MF10: 1210	1206 size = 1/2W	10ohm =100_			
MF20: 2010	1210 size = 1/2W	56Kohm =563_			
MF25: 2512	2010 size = 1W	( "_ means a blank )			
	2512 size = 2W				
		1%, E24+E96:			
		3 significant digits followed by No. of zeros			
		100Ω =1000			
		37.4KΩ =3742			

- Reeled tape packaging : 8mm width paper taping 5000pcs per 7" reel for 0603-1210 sizes.
- Reeled tape packaging : 12mm width plastic taping 4000pcs per 7" reel for 2010, 2512 sizes.

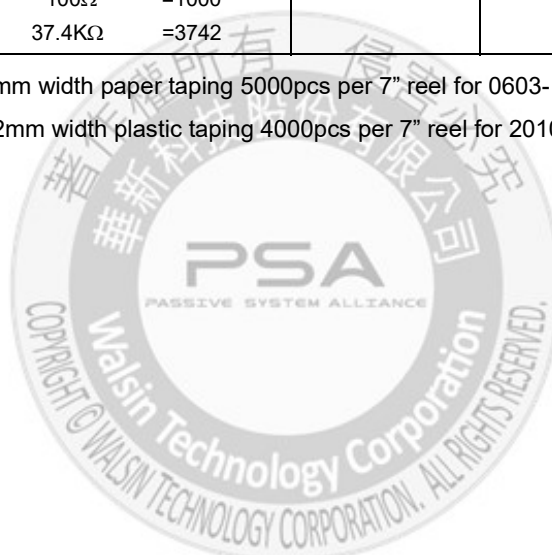

TEST AND REQUIREMENTS ( refer to AEC Q200 )

TEST	PROCEDURE / TEST METHOD	REQUIREMENT
		Resistor
Electrical Characteristics  <b>JISC5201-1: 1998</b> Clause 4.8	- DC resistance values measurement - Temperature Coefficient of Resistance (T.C.R) Natural resistance change per change in degree centigrade. $\frac{R_2 - R_1}{R_1(t_2 - t_1)} \times 10^6 \text{ (ppm/}^\circ\text{C)} \quad t_1 : 20^\circ\text{C}+5^\circ\text{C}-1^\circ\text{C}$ R <sub>1</sub> : Resistance at reference temperature R <sub>2</sub> : Resistance at test temperature	Within the specified tolerance Refer to "QUICK REFERENCE DATA"
Resistance to soldering heat(R.S.H) <b>MIL-STD-202 method 210</b>	Un-mounted chips completely immersed for 10±1second in a SAC solder bath at 270°C±5°C	ΔR/R max. ±(1.0%+0.05Ω) no visible damage
Solderability <b>J-STD-002</b>	a) Bake the sample for 155°C dwell time 4hrs/ solder dipping 235°C/ 5sec. b) Steam the sample dwell time 8 hour/ solder dipping 215°C/ 5sec. c) Steam the sample dwell time 8 hour/ solder dipping 260°C/ 7sec.	95% coverage min., good tinning and no visible damage
Temperature cycling <b>JESD22 Method JA-104</b>	1000 cycles, -55°C ~ +155°C, dwell time 30min maximum.	ΔR/R max. ±(0.5%+0.05Ω) No visible damage
Moisture Resistance <b>MIL-STD-202 method 106</b>	65±2°C, 80~100% RH, 10 cycles, 24 hours/ cycle	ΔR/R max. ±(0.5%+0.05Ω) No visible damage
Bias Humidity <b>MIL-STD-202 method 103</b>	1000+48/-0 hours; 85°C, 85% RH, 10% of operation power	ΔR/R max. ±(1.0%+0.05Ω) No visible damage
Operational Life <b>MIL-STD-202 method 108</b>	1000+48/-0 hours; 35% of operation power, 125±2°C	ΔR/R max. ±(1.0%+0.05Ω) No visible damage
High Temperature Exposure <b>MIL-STD-202 Method 108</b>	1000+48/-0 hours; without load in a temperature chamber controlled 155±3°C	ΔR/R max. ±(1.0%+0.05Ω) No visible damage
Board Flex <b>AEC-Q200-005</b>	Resistors mounted on a 90mm glass epoxy resin PCB(FR4),bending once 2mm for 60sec.	ΔR/R max. ±(0.5%+0.05Ω) No visible damage
Terminal strength <b>AEC-Q200-006</b>	Force: 1.8Kg, Test time: 60±1sec.	No remarkable damage or removal of the terminations
Thermal shock <b>MIL-STD-202 method 107</b>	Test -55 to 155°C/ dwell time 15min/ Max transfer time 20sec 300cycles	ΔR/R max. ±(0.5%+0.05Ω) No visible damage



TEST	PROCEDURE / TEST METHOD	REQUIREMENT
		Resistor
Mechanical Shock <b>MIL-STD-202 method 213</b>	Test ½ Sine Pulse, Peak value: 100g, normal duration: 6ms, Velocity change:12.3ft/sec. Three shocks in each direction, total 18 shocks.	Within product specification tolerance and no visible damage.
Vibration <b>MIL-STD-202 method 204</b>	Test 5g's for 20 min., 12 cycles each of 3 orientations.	$\Delta R/R$ max. $\pm(1\%+0.05\Omega)$ and no visible damage
Resistance to Solvents : <b>MIL-STD-202 Method 215</b>	Solvent is Isopropyl alcohol, immersion 3mins at 25°C and brush 10 strokes with a toothbrush with a handle made of a non-reactive material (wet bristle), immersion and brush 3 times and then air blow dry.	No superficial defect on marking, encapsulation, coating, appearance. Electrical characteristics within products specification and tolerance. Inspect at 3X max. for marking, inspect at 10X for part damage.
External Visual <b>MIL-STD-883 method 2009</b>	Electrical test not required. Inspect device construction, marking and workmanship	No visual damage and refer WTC marking code.
Physical Dimension <b>JESD22 method JB-100</b>	Verify physical dimensions(L, W, T, Tb, Tt)	Within the specified tolerance for WTC.
Short time overload (S.T.O.L) <b>Clause 4.13</b>	5×Rated power or Max. Overload voltage for 5 sec. Measure the resistance after 30 minutes.	no visible damage $\Delta R/R$ max. $\pm(1\%+0.05\Omega)$
Sulfuration test	ASTM B-809 50°C 90% RH, 1000hrs	$\Delta R/R$ max. $\pm(2.0\%+0.05\Omega)$ No visible damage

## PACKAGING

### Paper Tape specifications (unit :mm)

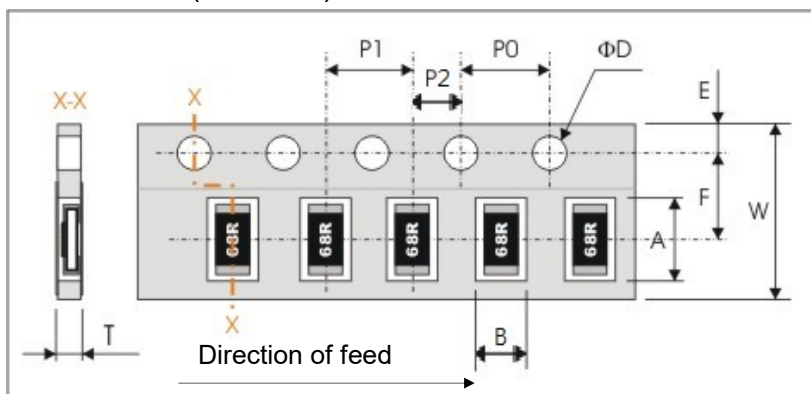

Series No.	A	B	W	F	E
MF25P	6.75±0.20	3.50±0.20	12.00±0.30	5.50±0.10	1.75±0.10
MF20P	5.50±0.20	2.80±0.20			
MF10P	3.60±0.20	3.00±0.20	8.00±0.30	3.50±0.20	1.75±0.10
WF12P	3.60±0.20	2.00±0.20			
MF08P	2.40±0.20	1.65±0.20			
MF06P	1.90±0.20	1.10±0.20			
MF04P	1.20±0.10	0.70±0.10			

Series No.	P1	P0	P2	ΦD	T
MF25P	4.00±0.10	4.00±0.10	2.00±0.10	Φ1.50 <sup>+0.1</sup> <sub>-0.0</sub>	Max. 1.2
MF20P					Max. 1.2
MF10P					Max. 1.0
WF12P					Max. 1.0
MF08P					Max. 1.0
MF06P					0.65±0.05
MF04P	2.00±0.10				0.40±0.05

### Reel dimensions

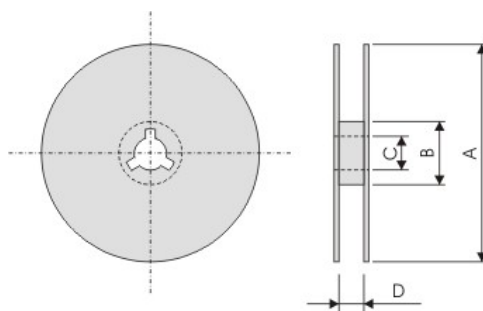

Symbol	A	B	C	D
12 mm tape	Φ178.0±2.0	Φ60.0±1.0	13.0±0.2	12.4±1.0
8 mm tape	Φ178.0±2.0	Φ60.0±1.0	13.0±0.2	9.0±0.5

单击下面可查看定价，库存，交付和生命周期等信息

[>>Walsin Technology\(华新科技\)](#)