



GDTN2RS3B-XX

Gas Discharge Tube

Features

- Excellent SMD handling
- Extremely small size
- Very fast response time
- Stable performance over life
- Extremely low capacitance
- High insulation resistance

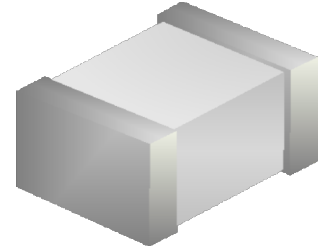

Application

- Modem
- Splitter
- Application with limited space
- Line cards
- PCI cards

Electrical specifications

Part number	DC Spark-over Voltage ^{1) 2)}	Maximum Impulse Spark-over Voltage	Service Life ³⁾	Insulation resistance	Capacitance	Marking Code
		1kv/ μ s	8/20 μ s 10times	@ 100V _{DC}	@ 1 MHz	
	(V)	(V)	(KA)	(G Ω)	(pF)	
GDTN2RS3B-75	75 \pm 30%	550	0.5KA	>1@50V _{DC}	< 1	None
GDTN2RS3B-90	90 \pm 30%	550	0.5KA	>1@50V _{DC}	< 1	None
GDTN2RS3B-150	150 \pm 30%	600	0.5KA	> 1	< 1	None
GDTN2RS3B-200	200 \pm 20%	600	0.5KA	> 1	< 1	None
GDTN2RS3B-230	230 \pm 20%	650	0.5KA	> 1	< 1	None
GDTN2RS3B-300	300 \pm 20%	850	0.5KA	> 1	< 1	None
GDTN2RS3B-350	350 \pm 20%	900	0.5KA	> 1	< 1	None
GDTN2RS3B-400	400 \pm 20%	950	0.5KA	> 1	< 1	None
GDTN2RS3B-400LV	400 \pm 20%	850	0.5KA	> 1	< 1	None

1) At delivery AQL 0.65 level II, DIN ISO 2859.

2) In ionized mode.

3) Tests according to ITU-T Rec. K. 12 and UL 497B.

Terms and current waveforms in accordance with: ITU-T Rec. K.12; IEC 61643-21 and DIN 57845/VDE0845.

Thermal Resistances

Symbol	Parameter	Value	Unit
Ts & Tj	Storage & Operating temperature range	-40 to +85	°C

Soldering Parameters

Reflow Condition		Pb – Free assembly
Pre Heat	Temperature Min ($T_{s(min)}$)	150°C
	Temperature Max ($T_{s(max)}$)	200°C
	Time (min to max) (t_s)	60 – 190 secs
Average ramp up rate (Liquidus Temp) (T_L) to peak		5°C/second max
$T_{s(max)}$ to T_L Ramp-up Rate		5°C/second max
Reflow	Temperature (T_L) (Liquidus)	217°C
	Temperature (t_L)	60 – 150 seconds
Peak Temperature (T_P)		260 ^{+0/-5} °C
Time within actual peak Temperature (t_p)		20 – 40 seconds
Ramp-down Rate		5°C/second max
Time 25°C to peak Temperature (T_P)		8 minutes Max.
Do not exceed		260°C

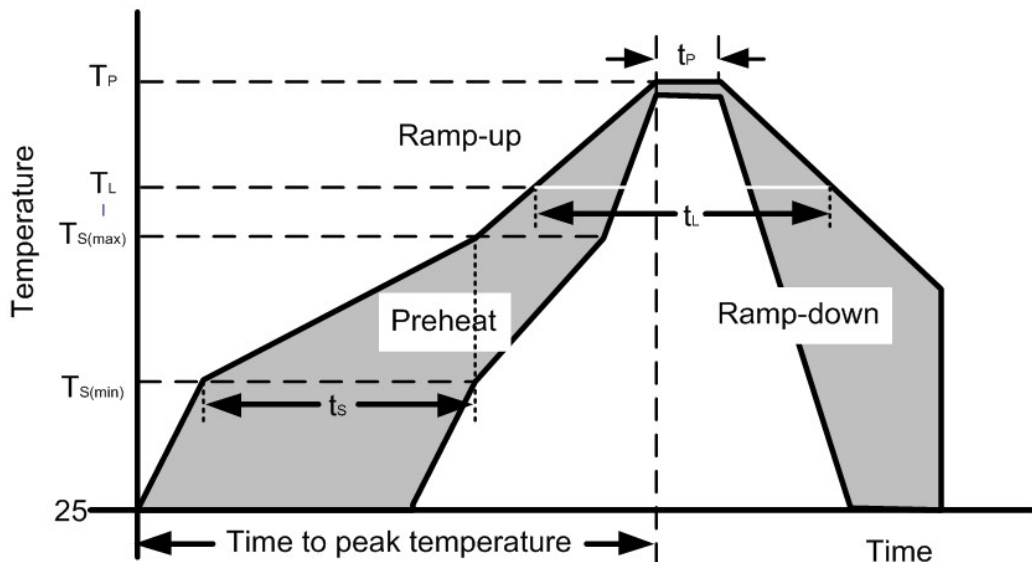

Dimensional drawing

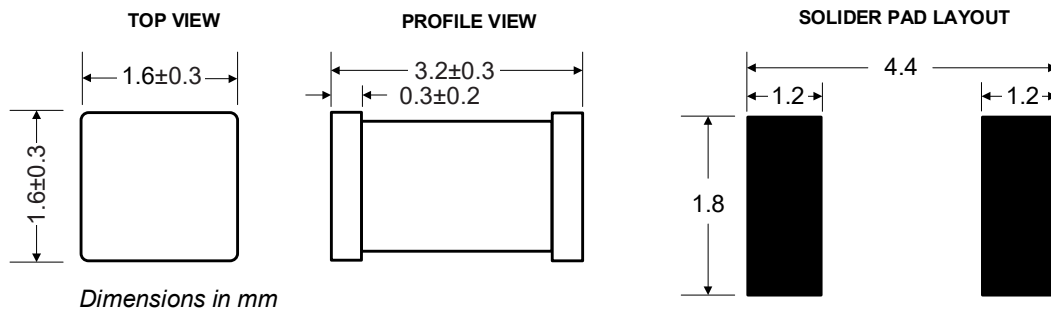

Cautions and warnings

- Surge arresters must not be operated directly in power supply networks.
- Surge arresters may become hot in case of longer periods of current stress (danger of burning).
- Surge arresters may be used only within their specified values. In case of overload, the headcontacts may fail or the component may be destroyed.
- Damaged surge arresters must not be re-used.

Part Numbering System

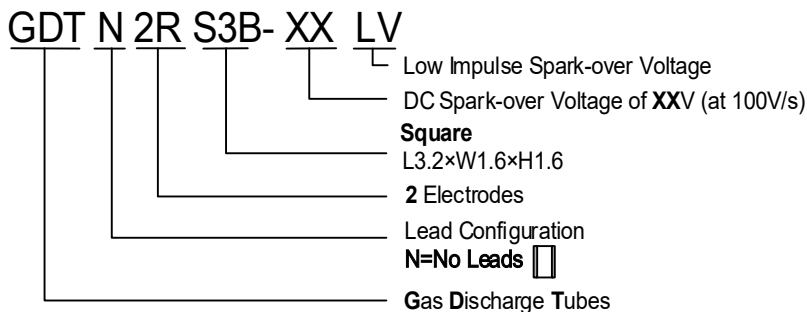

Package Information

Tape and Reel: 2000pcs per reel.

Contact Information

No.1001, Shiwan(7) Road, Pudong District, Shanghai, P.R.China.201207

Tel: 86-21-68969993 Fax: 86-21-50757680 Email: market@way-on.com

WAYON website: <http://www.way-on.com>

For additional information, please contact your local Sales Representative.

WAYON ® are registered trademarks of Wayon Corporation.

*Specifications are subject to change without notice.
The device characteristics and parameters in this data sheet can and do vary in different applications and actual device performance may vary over time.
Users should verify actual device performance in their specific applications.*

单击下面可查看定价，库存，交付和生命周期等信息

[>>WAY-ON\(维安\)](#)