

### Features

- Low operating voltage: 5V
- Low capacitance
- Solid-state silicon-avalanche and active circuit Triggering technology
- Back-drive protection for power-down mode
- Lead-free version available

### IEC COMPATIBILITY (EN61000-4)

- IEC 61000-4-2 (ESD)  $\pm 18\text{kV}$  (air),  $\pm 12\text{kV}$  (contact)
- IEC 61000-4-4 (EFT) 40A (5/50ns)
- IEC 61000-4-5 (Lightning) 3A (8/20 $\mu\text{s}$ )

### Mechanical Characteristics

- SOT-23-6L package
- Marking: Marking Code
- Packaging: Tape and Reel
- RoHS and Halogen Free Compliant

### Applications

- Video Graphics Cards
- Digital Visual Interface (DVI)
- USB2.0 Power and Data lines protection
- Notebook and PC Computers
- Monitors and Flat Panel Displays



### Circuit Diagram

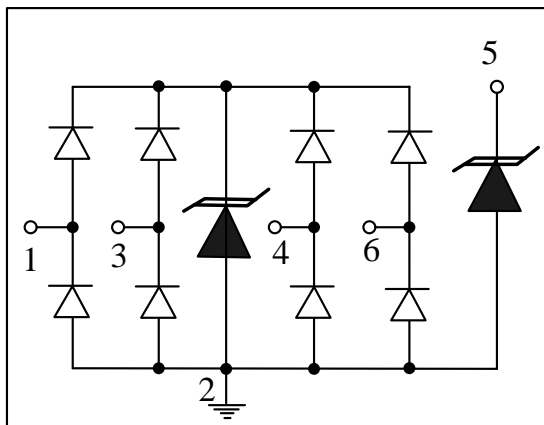

### Schematic & PIN Configuration

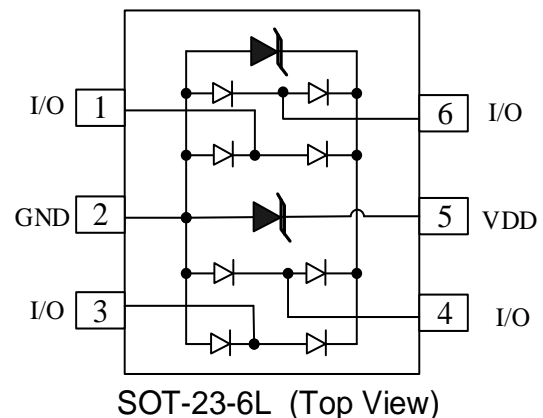

Absolute Maximum Rating			
Rating	Symbol	Value	Units
Peak Pulse Power ( $t_p = 8/20\mu s$ )	$P_{PP}$	42	Watts
Peak Pulse Current ( $t_p = 8/20\mu s$ )	$I_{PP}$	3	A
Operating Temperature	$T_J$	-55 to +125	°C
Storage Temperature	$T_{STG}$	-55 to +150	°C

Electrical Parameters

Symbol	Parameter
$I_{PP}$	Reverse Peak Pulse Current
$V_C$	Clamping Voltage @ $I_{PP}$
$V_{RWM}$	Reverse Stand-Off Voltage
$I_R$	Reverse Leakage Current @ $V_{RWM}$
$V_{BR}$	Breakdown Voltage @ $I_T$
$I_T$	Test Current
$I_F$	Forward Current
$V_F$	Forward Voltage @ $I_F$

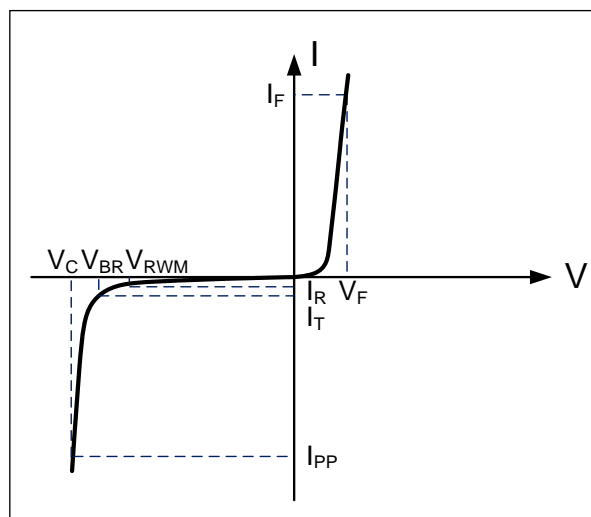

Electrical Characteristics(T=25°C unless otherwise noted)

WE05-5RVA						
Parameter	Symbol	Conditions	Minimum	Typical	Maximum	Units
Reverse Stand-Off Voltage	$V_{RWM}$	$T=25^\circ C$ Pin 5 to pin 2			5	V
Reverse Breakdown Voltage	$V_{BR}$	$I_T=1mA$ Pin 5 to pin 2	6		9	V
Reverse Leakage Current	$I_R$	$V_{RWM}=5V$ I/O pin to GND			500	nA
Clamping Voltage	$V_C$	$I_{PP}=3A, t_p=8/20\mu s$ I/O pin to GND		11.5	14	V
Dynamic Resistance <sup>1,2</sup>	$R_{DYN}$	$TLP=0.2/100ns$ I/O pin to GND		0.64		$\Omega$
ESD Clamping Voltage <sup>1</sup>	$V_C$	$I_{PP} = 4A,$ $t_p = 0.2/100ns$ (TLP)		10.9		V
ESD Clamping Voltage <sup>1</sup>	$V_C$	$I_{PP} = 16A,$ $t_p = 0.2/100ns$ (TLP)		18.6		V
Junction Capacitance	$C_j$	$V_R = 0V, f = 1MHz$ I/O pin to GND		0.65	1.0	pF
		$V_R = 0V, f = 1MHz$ Between I/O pins		0.26	0.5	pF

Notes : 1、 TLP Setting :  $t_p=100ns, t_r=0.2ns, I_{TLP}$  and  $V_{TLP}$  sample window: $t_1=70ns$  to  $t_2=90ns$ .  
 2、 Dynamic resistance calculated from  $I_{PP}=4A$  to  $I_{PP}=16A$  using "Best Fit".

Typical Characteristics

Figure 1: Peak Pulse Power vs. Pulse Time

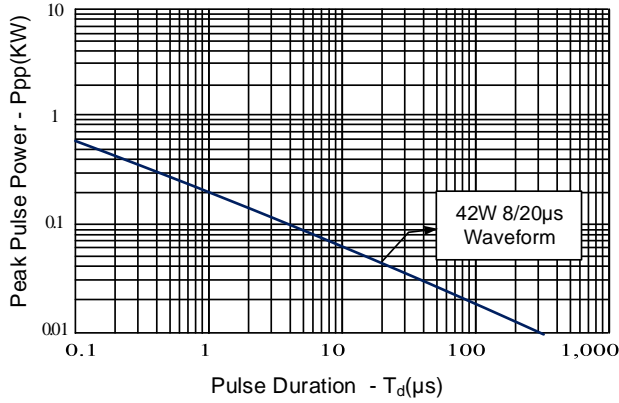

Figure 2: Power Derating Curve

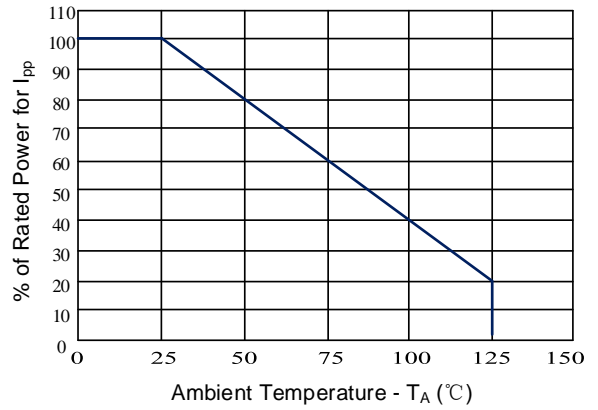

Figure 3: Clamping Voltage vs. Peak Pulse Current

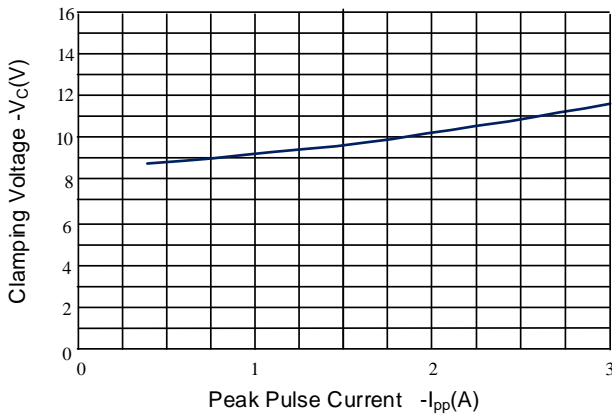

Figure 4: Normalized Junction Capacitance vs. Reverse Voltage

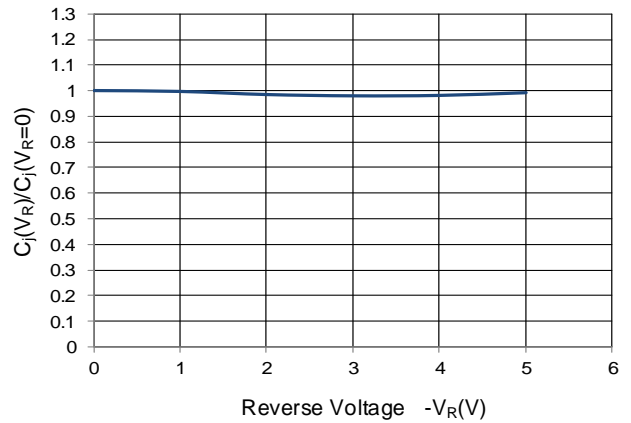

Figure 5: 8/20μs Pulse Waveform

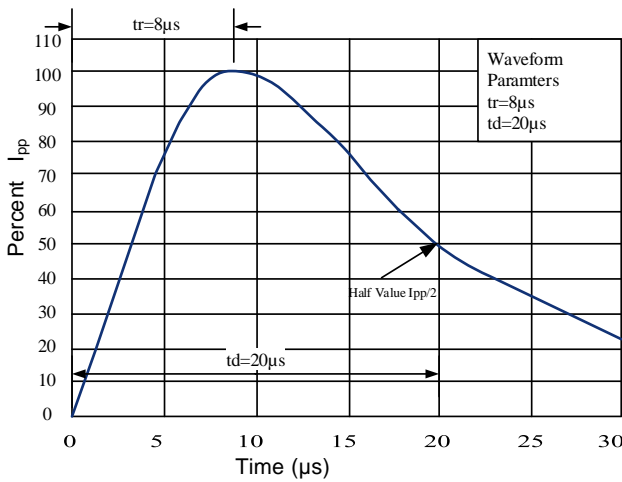
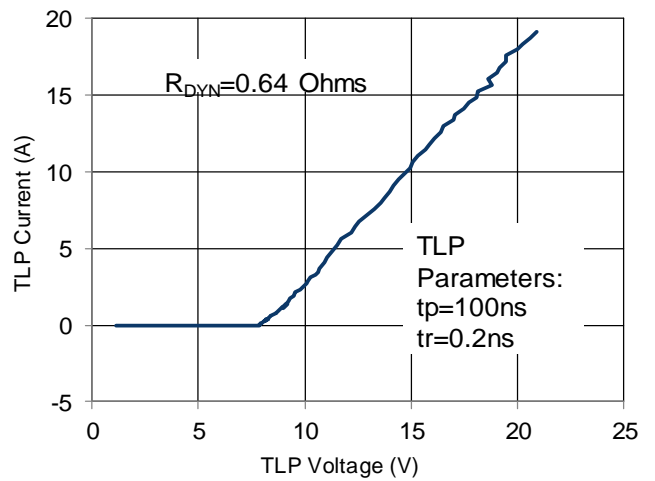
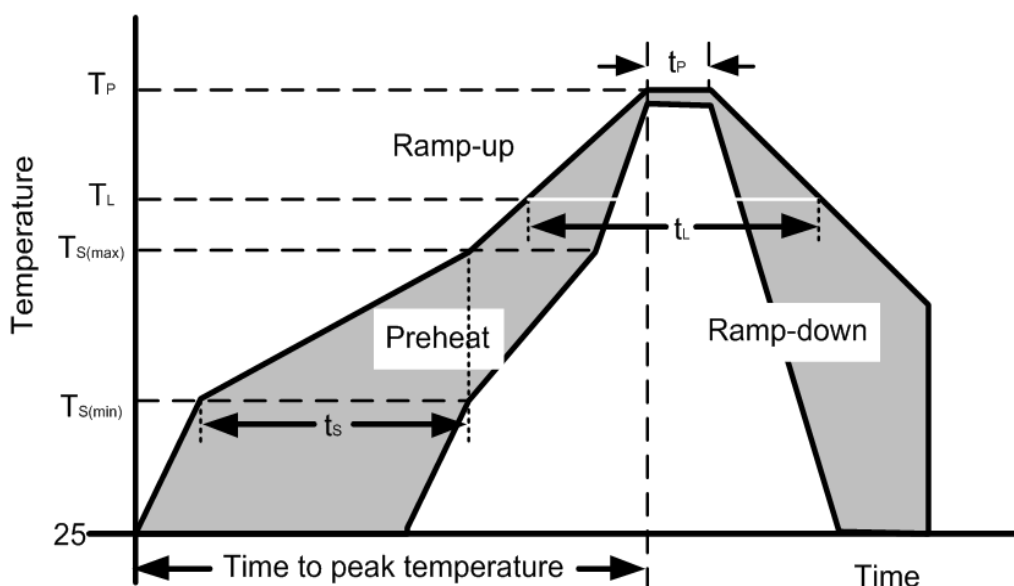

Figure 6: TLP I-V Curve



Soldering Parameters

Reflow Condition		Pb – Free assembly
Pre Heat	Temperature Min ( $T_{S(min)}$ )	150°C
	Temperature Max ( $T_{S(max)}$ )	200°C
	Time (min to max) ( $t_s$ )	60 – 190 secs
Average ramp up rate (Liquidus Temp) ( $T_L$ ) to peak		5°C/second max
$T_{S(max)}$ to $T_L$ — Ramp-up Rate		5°C/second max
Reflow	Temperature ( $T_L$ ) (Liquidus)	217°C
	Temperature ( $t_L$ )	60 – 150 seconds
Peak Temperature ( $T_P$ )		260+0/-5 °C
Time within actual peak Temperature ( $t_p$ )		20 – 40 seconds
Ramp-down Rate		5°C/second max
Time 25°C to peak Temperature ( $T_P$ )		8 minutes Max.
Do not exceed		280°C



Outline Drawing – SOT-23-6L

**PACKAGE OUTLINE**

SOT-23-6L

DIMENSIONS				
DIM	INCHES		MILLIMETERS	
	MIN	MAX	MIN	MAX
A	0.035	0.057	0.90	1.45
A1	0.000	0.006	0.00	0.15
A2	0.035	0.051	0.90	1.30
b	0.014	0.020	0.35	0.50
c	0.003	0.008	0.08	0.20
D	0.110	0.119	2.80	3.02
E1	0.060	0.069	1.50	1.75
E	0.102	0.118	2.60	3.00
e	0.037 BSC		0.95 BSC	
e1	0.075 BSC		1.90 BSC	
L	0.014	0.024	0.35	0.60
L1	0.022	0.030	0.55	0.75
θ 1	0°	8°	0°	8°
N	6		6	

DIMENSIONS		
DIM	INCHES	MILLIMETERS
C	0.098	2.50
G	0.055	1.40
P	0.037	0.95
X	0.024	0.60
Y	0.043	1.10
Z	0.141	3.60

**Notes:**

Controlling Dimension: Millimeter.

**Marking Codes**

Part Number	WE05-5RVA
Marking Code	

**Package Information**

Qty: 3k/Reel

**CONTACT INFORMATION**

No.1001, Shiwan (7) Road, Pudong District, Shanghai, P.R.China.201207

Tel: 86-21-68969993 Fax: 86-21-50757680 Email: [market@way-on.com](mailto:market@way-on.com)

WAYON website: <http://www.way-on.com>

For additional information, please contact your local Sales Representative.

**WAYON** ® is registered trademark of Wayon Corporation.

Specifications are subject to change without notice.  
The device characteristics and parameters in this data sheet can and do vary in different applications and actual device performance may vary over time.  
Users should verify actual device performance in their specific applications.

单击下面可查看定价，库存，交付和生命周期等信息

[>>WAY-ON\(维安\)](#)