

WPFxxAxH

Series (Rev:D)

Surface-mount devices

1. Features

- Halogen free;
- SMD Electronic devices;
- High structural intensity;
- Over current protection ;
- Over charge protection;
- Compatible with reflow soldering processes
- UL file number: E311435



2. Environmental Characteristics

(1) Contents of halogens used in each material for the product are as follows.

| Halogen substance | Content |
|---|-------------------|
| Chlorine (CL) | ≤ 900ppm (0.09%) |
| Bromine (Br) | ≤ 900ppm (0.09%) |
| Total concentration of chlorine (Cl) + bromine (Br) | ≤ 1500ppm (0.15%) |

(2) The product described in this specification complies with the RoHS Directive. BOM table contains the high-temperature alloy, solder, some electronic slurry, including lead, but are in line with the relevant provisions of the ROHS directive.

3. Dimensions and Circuit Chart

3.1 Dimensions

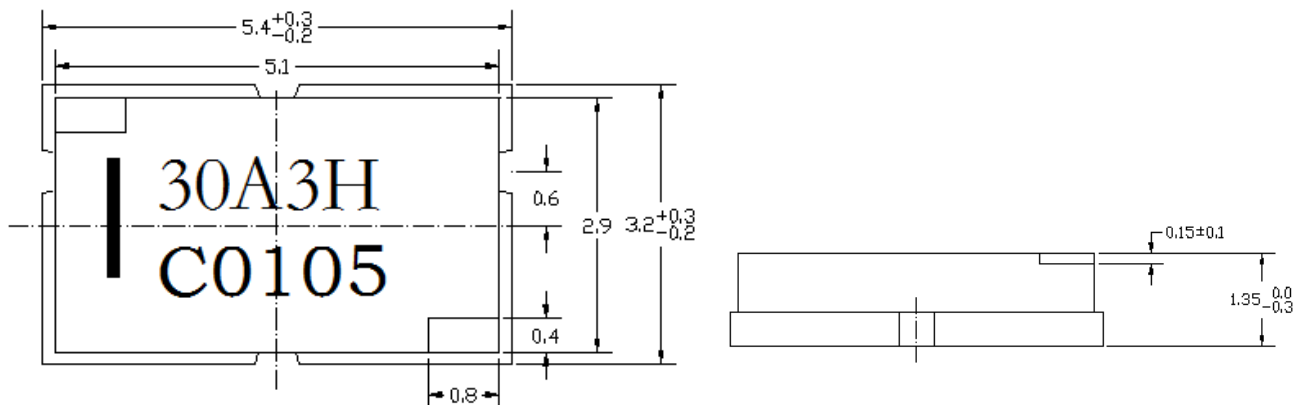

Unit: mm
Tolerances Unless

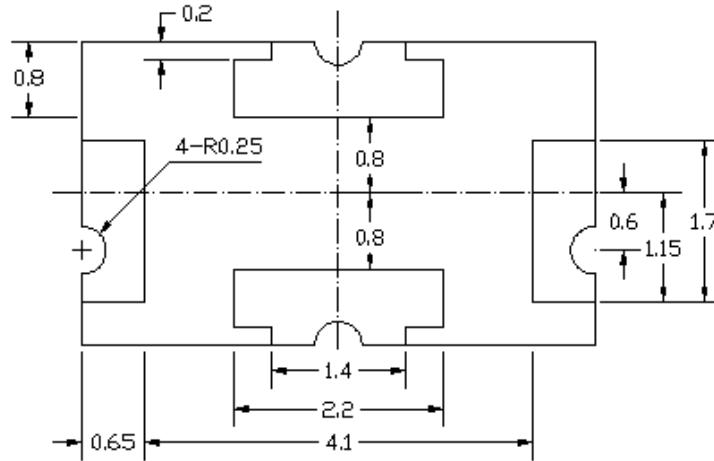

3.2 Construction

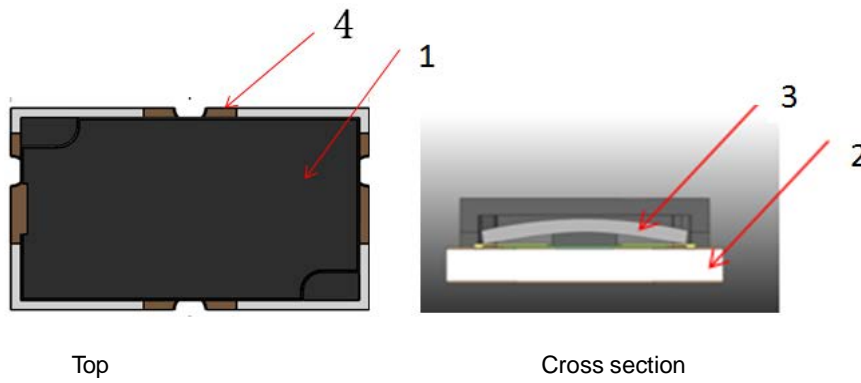

Note: The top cover of the product shown in the figure does not distinguish between the right and the left.

| No. | Name | Material |
|-----|-----------------------|--------------------------------|
| 1 | Cap | LCP |
| 2 | Ceramic | Al ₂ O ₃ |
| 3 | Alloy | Sn/Ag |
| 4 | Termination electrode | Ag/Pd/Ni/Au |

3.3 Circuit Chart

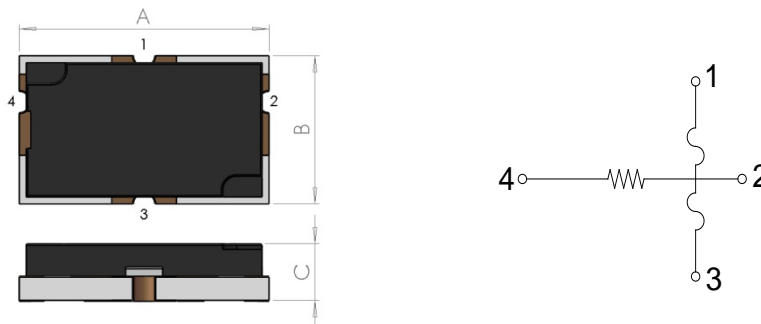

4. Marking requirements

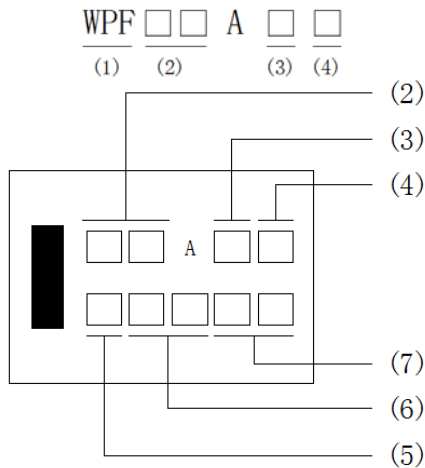

- (1) WPF: SCF/Way-on SCF protector
- (2) Rated current; 12A、15A、30A.....
- (3) Number of electric core string
- (4) Length width size code; H:5.4×3.2mm
- (5) Year: D:2018; E:2019.....
- (6) Week of year; 01、02.....52.
- (7) Running number; 01、02.....

5. Specifications

| Part number | Rated current | Rated voltage ★ | Operating Voltage | Fuse DCR | Breaking capacity | Applicable Cells in series |
|-------------|---------------|--------------------|-------------------|----------|-------------------|----------------------------|
| | A | VDC | V | m Ω | A | cell |
| WPF12A1H | 12 | 36 | 4.0-7.0 | 1.5-3.5 | 50 | 1 |
| WPF12A2H | 12 | 36 | 4.0-9.0 | 1.5-3.5 | 50 | 2 |
| WPF12A3H | 12 | 36 | 7.4-13.8 | 1.5-3.5 | 50 | 3 |
| WPF12A4H | 12 | 36 | 10.5-19.6 | 1.0-3.5 | 50 | 4 |
| WPF12A5H | 12 | 36 | 14.4-23.5 | 1.0-3.0 | 50 | 5 |
| WPF12A5H-10 | 12 | 62 | 42-62.0 | 1.0-3.5 | 50 | 14 |
| WPF15A3H | 15 | 36 | 7.4-13.8 | 1.0-3.0 | 50 | 3 |
| WPF15A4H | 15 | 36 | 10.5-19.6 | 1.0-3.0 | 50 | 4 |
| WPF15A5H | 15 | 36 | 14.4-23.5 | 1.0-3.0 | 50 | 5 |
| WPF15A5H-3 | 15 | 36 | 17.3-28.20 | 1.0-3.0 | 50 | 6 |
| WPF30A1H | 30 | 62 | 4.0-4.7 | 0.5-2.5 | 80 | 1 |
| WPF30A2H | 30 | 62 | 6.6-9.0 | 0.5-2.5 | 80 | 2 |
| WPF30A3H | 30 | 62 | 9.9-13.5 | 0.5-2.5 | 80 | 3 |
| WPF30A4H | 30 | 62 | 13.4-18.4 | 0.5-2.5 | 80 | 4 |
| WPF30A5H | 30 | 62 | 17.1-23.5 | 0.5-2.5 | 80 | 5 |
| WPF30A7H-3 | 30 | 62 | 19.8-27.0 | 0.5-2.5 | 80 | 6 |
| WPF30A7H | 30 | 62 | 23.0-31.5 | 0.5-2.5 | 80 | 6-7 |
| WPF30A7H-2 | 30 | 62 | 26.5-36.0 | 0.5-2.5 | 80 | 7-8 |
| WPF30A10H | 30 | 62 | 34.2-46.9 | 0.5-2.5 | 80 | 9-10 |
| WPF30A10H-4 | 30 | 62 | 45.2-58.5 | 0.5-2.5 | 80 | 13 |
| WPF30A14H | 30 | 62 | 45.2-62.0 | 0.5-2.5 | 80 | 12-14 |

★Rated voltage is the maximum voltage that the fuse can block, not the action voltage of the heater assembly.

6. Clear-Time Characteristics

| Condition of Test | Clear-time at 25°C |
|--------------------|--------------------|
| 100% rated Current | 1 hours (min) |
| 200% rated Current | 60 sec (max) |
| Operating Voltage | 60 sec (max) |

Electrical Characteristics is influenced by thermal capacity of PCB, parts, pattern width, and so on. Therefore you should check it on your PCB.

7. Standard test condition

In the absence of additional test environmental standards, the test environmental standards are as follows;

Ambient temperature : 5 to 35°C;

Relative humidity : 45 to 85%RH;

Air pressure : 86 to 106kPa.

If you have any questions about the test results, please follow the following environmental standards;

Ambient temperature : 20±2°C;

Relative humidity : 60 to 70%RH;

Air pressure : 86 to 106kPa.

8. Reliability

| Test Item | Project | Condition | Requirements |
|--------------------------|------------------------------|--|---|
| Electrical performance | Over voltage | Operating voltage shall be applied to heater. | Clearing time <60s |
| | Insulation | @100VDC after OV operating voltage test | >0.2MΩ |
| | Withstand voltage | @100VAC @50-60Hz@60s after OV operating voltage test | No breakdown |
| | Over current | 200% of Rated current | Clearing time <60s |
| | Hold current | 100% of Rated current,1hr | Without melting |
| Reliability performance | High temperature | 100°C±5°C @250hr | Without deformation of case or excessive looseness of caps. Electrical characteristics shall be satisfied. |
| | High humidity | 60°C±2°C @90%~95%@250hr | |
| | Keeping cold | -20°C±3°C @ 500hr | |
| | Pulse | 5×In (In = rated current) A @ 25°C @on 5ms/off 995 ms , 100,000 cycles | No operating; |
| Mounting Characteristics | Solder ability | Solder: Pb-free (Sn96.5/Ag3/Cu0.5[%]) Flux : 25wt%Rosin Ethanol solution Dipping depth : 2~2.5mm Temperature : 235±5°C Dipping time : 2±0.5S Dipping and drawing speed : 25±2.5mm/S | A new uniform coating of solder shall cover a minimum of 95% of the surface being immersed. |
| | Resistance to soldering heat | Reflow soldering method Peak temp : 255°C±5°C 5s, 230°C ±5°C 30s. At electrode temperature of the specimen.(Solder temperature) The specimen shall be passed through the reflow furnace for 2times. The specimen shall be stored at standard atmospheric conditions for 24h after which the measurement shall be made. | Without deformation of case or excessive looseness of caps. Electrical characteristics shall be satisfied. |

Electrical Characteristics is influenced by thermal capacity of PCB, parts, pattern width, and so on.

Therefore you should check it on your PCB.

9. Recommended Solder Pad Dimensions

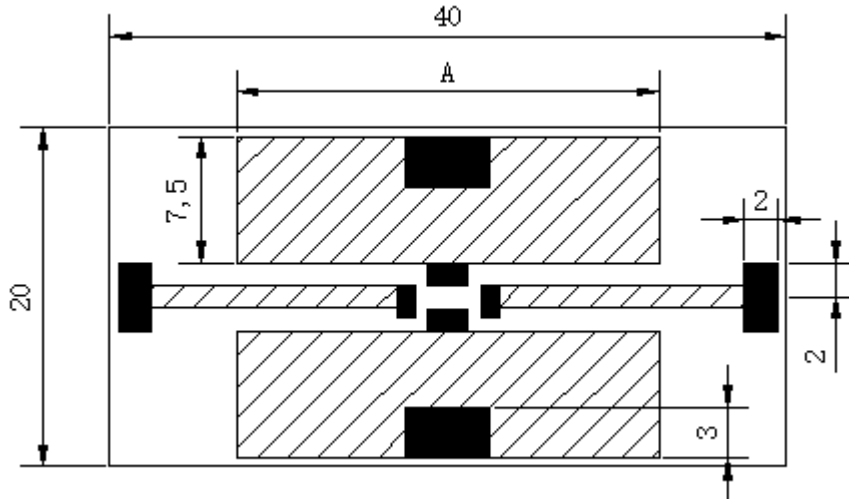

Unit: mm

| Type | Materials | Copper width A | Base thickness | Copper | Covered wires |
|------|-----------|----------------|----------------|--------|---------------|
| 12A | FR-4 | 2mm | 0.6 mm | 2.0OZ | AWG18 |
| 15A | FR-4 | 3.5mm | 0.6 mm | 2.0OZ | AWG18 |
| 30A | FR-4 | 25mm | 0.6 mm | 2.0OZ | AWG10 |

When the patch on the PCB board printed solder paste steel mesh thickness is best not more than 0.12m

10. Solder Reflow Recommendations

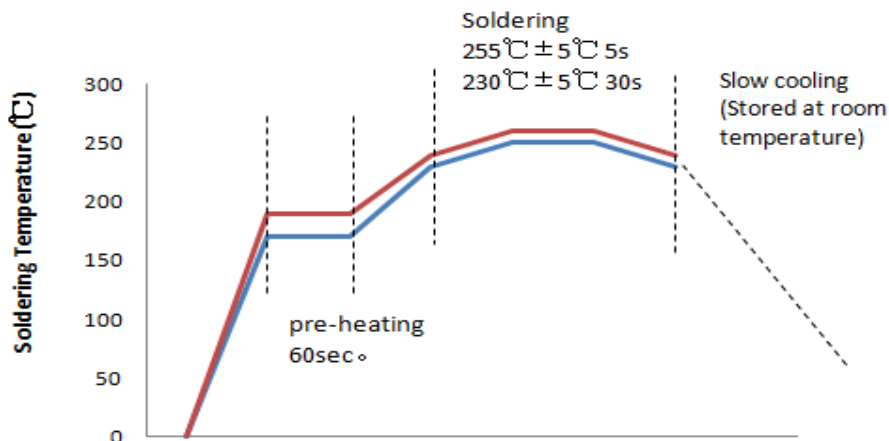

Reflow soldering method:

Peak temp : $255^{\circ}\text{C} \pm 5^{\circ}\text{C}$ 5s, $230^{\circ}\text{C} \pm 5^{\circ}\text{C}$ 30s. The specimen shall be passed through the reflow furnace for 2times.

11. Packaging Data

Package form is embossed tape packing.

11.1 Dimension of Tape and Reels

| Code | (mm) |
|------|-------------|
| E | 1.75±0.10 |
| F | 5.50±0.10 |
| P2 | 2.00±0.1 |
| D | 1.50+0.1/-0 |
| D1 | 1.50+0.1/-0 |
| P0 | 4.00±0.10 |
| 10P0 | 40.0±0.20 |
| W | 12.00±0.30 |
| P | 8.00±0.10 |
| A0 | 3.80±0.10 |
| B0 | 5.6±0.10 |
| K0 | 1.5±0.10 |
| t | 0.30±0.05 |

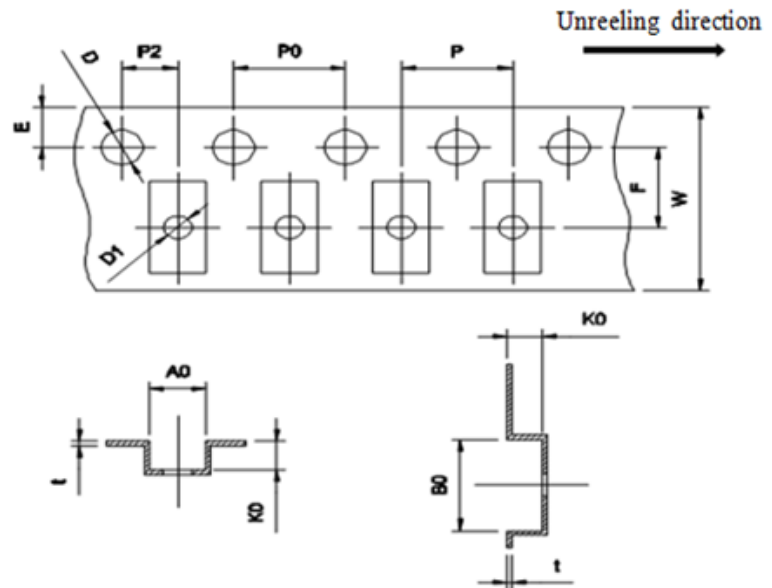

| Code | (mm) |
|------|----------|
| A | 330±1.0 |
| B | 2+0.5/-0 |
| C | 13±0.2 |
| D | 21±0.2 |
| W | 15.4±0.5 |

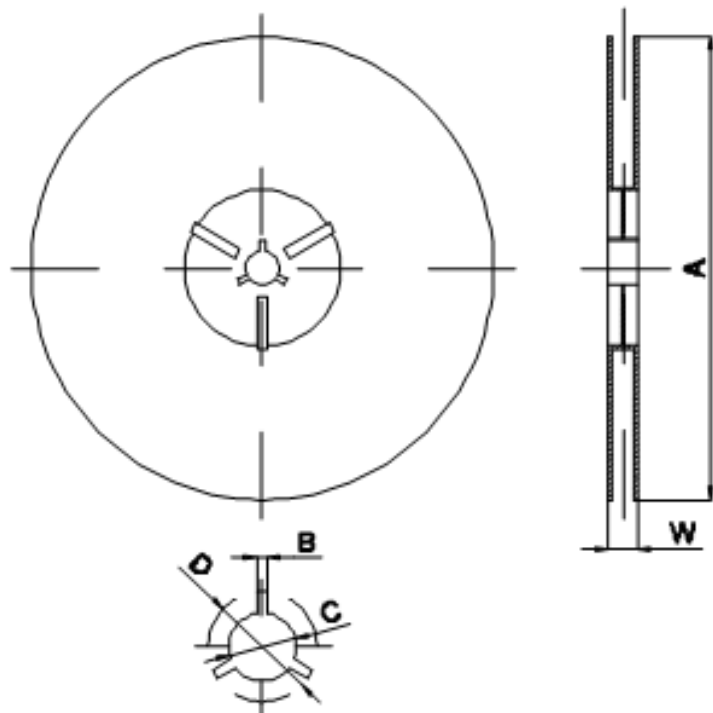

11.2 Packing Quantity

5000 pcs /reel.

11.3 Direction of Taping

The direction shall be seen from the top cover tape side.

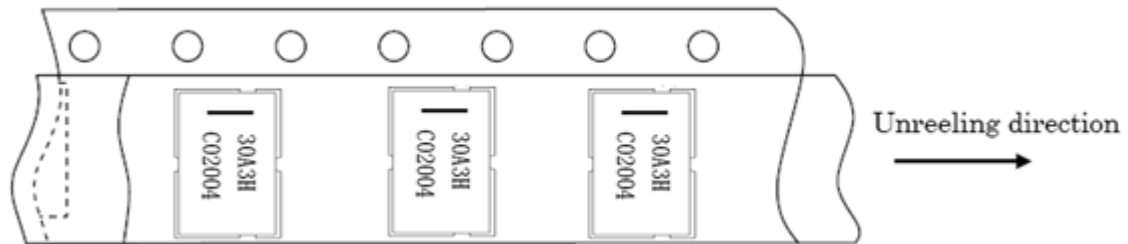

11.4 Label (example)

The label contains the following content:

- (1) manufacturer of trademark and factory address,
- (2) product type,
- (3) product batch number,
- (4) quantity,
- (5) shipment inspection personnel quality code,
- (6) date of shipment,
- (7) the certification mark.



12. Storage

The product must be stored in carton or plastic bag, in the conditions of ambient temperature of -10°C to 40°C, RH of less than 60%, no radical temperature change, no direct sunshine, excessive vibration and shock.

The preservation period when it is kept on the above condition is 3 month.

Should avoid to store at where there is possibility of generating corrosive gas, such as salt mist, chlorine, hydrogen sulfide, ammonium, sulfide-oxidation, hydrogen chloride, etc.

13. Cautions for using

(1)Can predict, the heat capacity of the test board current carrying capacity of a heater to work with the use of the relevant characteristics, therefore, before use to check the test board PCB you use, generally PCB plate heat capacity is bigger, the longer the action.

(2)The data referred to in this specification are tested under the PCB standard of UL(0.6t Glass Epoxy single-sided copper laminated), The characteristics influenced thermal capacity of PCB, on the machine before using the PCB to do the actual test to confirm the by.

(3) Ultrasonic-cleaning or immersion-cleaning and so on must not be done to SCF before and after mounted. When cleaning is done, flux on element would flow, and it would not be satisfied

its specification. Moreover, a similar influence happens when the product comes in contact with cleaning-solution. These products after cleaning will not be guaranteed..

(4)This product can not be used in resin packaging, packaging process of resin into the product, resulting in poor product performance.

(5)Please do not re-use of the product removed by the solder correction.

(6)Please confirm the connection with the three terminal circuit board , where in 1-3, 2-3 is used as a heating end with high resistance.

(7)This product is designed and used in conventional electronic devices, so we do not recommend the use of military, medical and other areas of other people and property may cause direct damage.

(8)If there is any doubt or change in the contents of this book, please inform us in advance so that both parties can reach an agreement.

单击下面可查看定价，库存，交付和生命周期等信息

[>>WAY-ON\(维安\)](#)