

Features

- 200 watts Peak Pulse Power (10/1000 μ s)
- Unidirectional and Bidirectional Protection
- Fast Response Time : Typically < 1ns
- Excellent Clamping Capability
- Built-in Strain relief
- Low inductance
- Low profile package
- High temperature solder:260°C/10 seconds at terminal

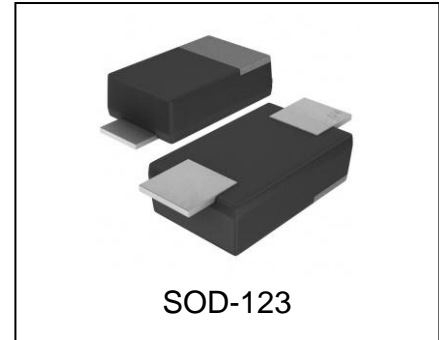

Mechanical Characteristics

- SOD-123 package
- Matte tin lead - free plated
- Marking: Marking Code
- RoHS Compliant

Applications

- I/O Interfaces
- Power lines
- Automotive and Telecommunication
- Industrial Electronics

Absolute Maximum Rating			
Rating	Symbol	Value	Units
Peak Pulse Power ($t_p = 10/1000\mu s$) (see Note1&2)	P_{PPM}	200	Watts
Peak pulse current (10/1000 μ s) (see Note2)	I_{PPM}	See Electrical Characteristics	A
Peak Forward surge current (see Note3)	I_{FSM}	20	A
Power Dissipation on infinite heat sink $T_L = 50^\circ C$ (Fig5)	P_D	1.0	W
Operating Junction Temperature range	T_J	-55 to + 150	$^\circ C$
Thermal Resistance Junction-to-Ambient	$R_{\theta JA}$	180	$^\circ C/W$

Note1: Peak Pulse Power Rating as Pulse Width ,per Fig1.

Note2: Peak Pulse Power or Current Derated above $T_A=25^\circ C$ Per Fig. 2 and Non-Repetitive Current Pulse,Per Fig.3.

Note3: 8.3ms Single Half Sine Wave or Equivalent Square Wave unidirectional device only.

Pin Configuration

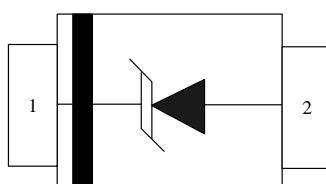

SMFxxA

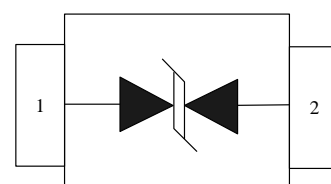

SMFxxCA

Electrical Characteristics

Part Number	Marking code	Reverse Stand off Voltage V_{RWM} (Volts)	Breakdown Voltage $V_{BR@I_T}$ (Volts)		Test Current I_T (mA)	Maximum Clamping Voltage $V_C@I_{PP}$ (Volts)	Maximum Peak Pulse Current I_{pp} (Amps)	Maximum Reverse Leakage $I_R@V_{RWM}$ (μ A)
			MIN	MAX				
SMF5.0CA	ETE	5.0	6.4	7.0	10	9.2	21.7	400
SMF6.0CA	ETG	6.0	6.67	7.37	10	10.3	19.4	400
SMF6.5CA	ETK	6.5	7.22	7.98	10	11.2	17.9	250
SMF7.0CA	ETM	7.0	7.78	8.6	10	12	16.7	100
SMF7.5CA	ETP	7.5	8.33	9.21	1	12.9	15.5	50
SMF8.0CA	ETR	8.0	8.89	9.83	1	13.6	14.7	25
SMF8.5CA	ETT	8.5	9.44	10.4	1	14.4	13.9	10
SMF9.0CA	ETV	9.0	10.0	11.1	1	15.4	13.0	5
SMF10CA	ETX	10	11.1	12.3	1	17	11.8	2.5
SMF11CA	ETZ	11	12.2	13.5	1	18.2	11.0	2.5
SMF12CA	EUE	12	13.3	14.7	1	19.9	10.1	2.5
SMF13CA	EUG	13	14.4	15.9	1	21.5	9.3	1
SMF14CA	EUK	14	15.6	17.2	1	23.2	8.6	1
SMF15CA	EUM	15	16.7	18.5	1	24.4	8.2	1
SMF16CA	EUP	16	17.8	19.7	1	26	7.7	1
SMF17CA	EUR	17	18.9	20.9	1	27.6	7.2	1
SMF18CA	EUT	18	20.0	22.1	1	29.2	6.8	1
SMF20CA	EUV	20	22.2	24.5	1	32.4	6.2	1
SMF22CA	EUX	22	24.4	26.9	1	35.5	5.6	1
SMF24CA	EUZ	24	26.7	29.5	1	38.9	5.1	1
SMF26CA	EVE	26	28.9	31.9	1	42.1	4.8	1
SMF28CA	EVG	28	31.1	34.4	1	45.4	4.4	1
SMF30CA	EVK	30	33.3	36.8	1	48.4	4.1	1
SMF33CA	EVM	33	36.7	40.6	1	53.3	3.8	1
SMF36CA	EVP	36	40.0	44.2	1	58.1	3.4	1
SMF40CA	EVR	40	44.4	49.1	1	64.5	3.1	1
SMF43CA	EVT	43	47.8	52.8	1	69.4	2.9	1
SMF45CA	EVV	45	50.0	55.3	1	72.7	2.8	1
SMF48CA	EVX	48	53.3	58.9	1	77.4	2.6	1
SMF51CA	EVZ	51	56.7	62.7	1	82.4	2.4	1
SMF54CA	EWE	54	60.0	66.3	1	87.1	2.3	1
SMF58CA	EWG	58	64.4	71.2	1	93.6	2.1	1
SMF60CA	EWK	60	66.7	73.7	1	96.8	1.8	1
SMF64CA	EWM	64	71.1	78.6	1	103	1.7	1
SMF70CA	EWP	70	77.8	86.0	1	113	1.5	1

Electrical Characteristics (Cont.)

Part Number	Marking Code	Reverse Stand off Voltage V_{RWM} (Volts)	Breakdown Voltage $V_{BR@I_T}$ (Volts)		Test Current I_T (mA)	Maximum Clamping Voltage $V_C@I_{PP}$ (Volts)	Maximum Peak Pulse Current I_{PP} (Amps)	Maximum Reverse Leakage $I_R@V_{RWM}$ (μ A)
			MIN	MAX				
SMF75CA	EWR	75	83.3	92.1	1	121	1.4	1
SMF78CA	EWT	78	86.7	95.8	1	126	1.4	1
SMF85CA	EWV	85	94.4	104	1	137	1.3	1
SMF90CA	EWX	90	100	111	1	146	1.2	1
SMF100CA	EWZ	100	111	123	1	162	1.1	1
SMF110CA	EXE	110	122	135	1	177	1.0	1
SMF120CA	EXG	120	133	147	1	193	0.9	1
SMF130CA	EXK	130	144	159	1	209	0.8	1
SMF150CA	EXM	150	167	185	1	243	0.7	1
SMF160CA	EXP	160	178	197	1	259	0.7	1
SMF170CA	EXR	170	189	209	1	275	0.6	1
SMF180CA	EXT	180	200	220	1	292	0.68	1
SMF190CA	EXV	190	211	232	1	308	0.65	1
SMF5.0A	EHE	5.0	6.4	7.0	10	9.2	21.7	400
SMF6.0A	EHG	6.0	6.67	7.37	10	10.3	19.4	400
SMF6.5A	EHK	6.5	7.22	7.98	10	11.2	17.9	250
SMF7.0A	EHM	7.0	7.78	8.6	10	12	16.7	100
SMF7.5A	EHP	7.5	8.33	9.21	1	12.9	15.5	50
SMF8.0A	EHR	8.0	8.89	9.83	1	13.6	14.7	25
SMF8.5A	EHT	8.5	9.44	10.4	1	14.4	13.9	10
SMF9.0A	EHV	9.0	10.0	11.1	1	15.4	13.0	5
SMF10A	EHX	10	11.1	12.3	1	17	11.8	2.5
SMF11A	EHZ	11	12.2	13.5	1	18.2	11.0	2.5
SMF12A	EIE	12	13.3	14.7	1	19.9	10.1	2.5
SMF13A	EIG	13	14.4	15.9	1	21.5	9.3	1
SMF14A	EIK	14	15.6	17.2	1	23.2	8.6	1
SMF15A	EIM	15	16.7	18.5	1	24.4	8.2	1
SMF16A	EIP	16	17.8	19.7	1	26	7.7	1
SMF17A	EIR	17	18.9	20.9	1	27.6	7.2	1
SMF18A	EIT	18	20.0	22.1	1	29.2	6.8	1
SMF20A	EIV	20	22.2	24.5	1	32.4	6.2	1
SMF22A	EIX	22	24.4	26.9	1	35.5	5.6	1
SMF24A	EIZ	24	26.7	29.5	1	38.9	5.1	1
SMF26A	EJE	26	28.9	31.9	1	42.1	4.8	1
SMF28A	EJG	28	31.1	34.4	1	45.4	4.4	1

Electrical Characteristics (Cont.)

Part Number	Marking Code	Reverse Stand off Voltage V_{RWM} (Volts)	Breakdown Voltage $V_{BR@I_T}$ (Volts)		Test Current I_T (mA)	Maximum Clamping Voltage $V_C@I_{PP}$ (Volts)	Maximum Peak Pulse Current I_{PP} (Amps)	Maximum Reverse Leakage $I_R@V_{RWM}$ (μ A)
			MIN	MAX				
SMF30A	EJK	30	33.3	36.8	1	48.4	4.1	1
SMF33A	EJM	33	36.7	40.6	1	53.3	3.8	1
SMF36A	EJP	36	40.0	44.2	1	58.1	3.4	1
SMF40A	EJR	40	44.4	49.1	1	64.5	3.1	1
SMF43A	EJT	43	47.8	52.8	1	69.4	2.9	1
SMF45A	EJV	45	50.0	55.3	1	72.7	2.8	1
SMF48A	EJX	48	53.3	58.9	1	77.4	2.6	1
SMF51A	EJZ	51	56.7	62.7	1	82.4	2.4	1
SMF54A	ERE	54	60.0	66.3	1	87.1	2.3	1
SMF58A	ERG	58	64.4	71.2	1	93.6	2.1	1
SMF60A	ERK	60	66.7	73.7	1	96.8	1.8	1
SMF64A	ERM	64	71.1	78.6	1	103	1.7	1
SMF70A	ERP	70	77.8	86	1	113	1.5	1
SMF75A	ERR	75	83.3	92.1	1	121	1.4	1
SMF78A	ERT	78	86.7	95.8	1	126	1.4	1
SMF85A	ERV	85	94.4	104	1	137	1.3	1
SMF90A	ERX	90	100	111	1	146	1.2	1
SMF100A	ERZ	100	111	123	1	162	1.1	1
SMF110A	ESE	110	122	135	1	177	1.0	1
SMF120A	ESG	120	133	147	1	193	0.9	1
SMF130A	ESK	130	144	159	1	209	0.8	1
SMF150A	ESM	150	167	185	1	243	0.7	1
SMF160A	ESP	160	178	197	1	259	0.7	1
SMF170A	ESR	170	189	209	1	275	0.6	1
SMF180A	EST	180	200	220	1	292	0.68	1
SMF190A	ESV	190	211	232	1	308	0.65	1

Typical Characteristics

Figure 1: Peak Pulse Power Rating Curve

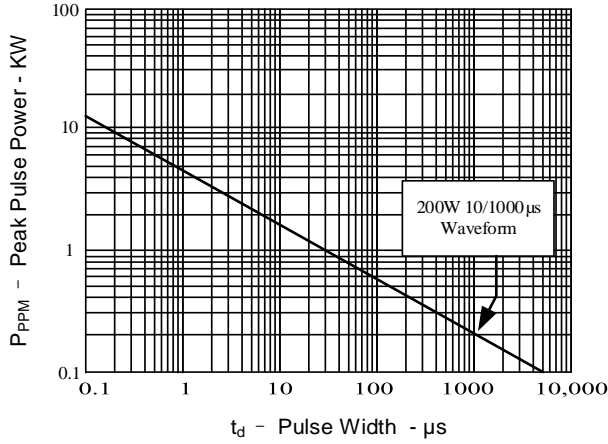

Figure 2: Pulse Derating Curve

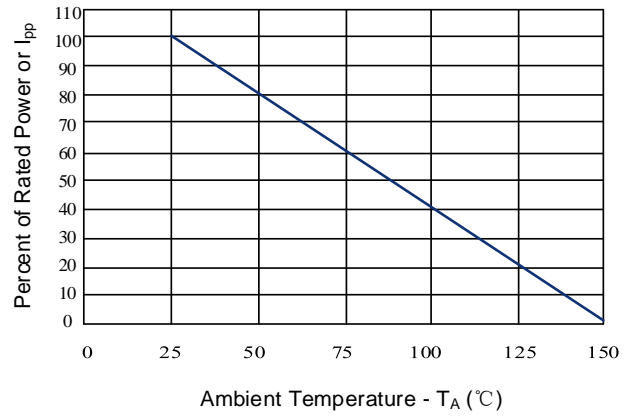

Figure 3: Pulse Waveform

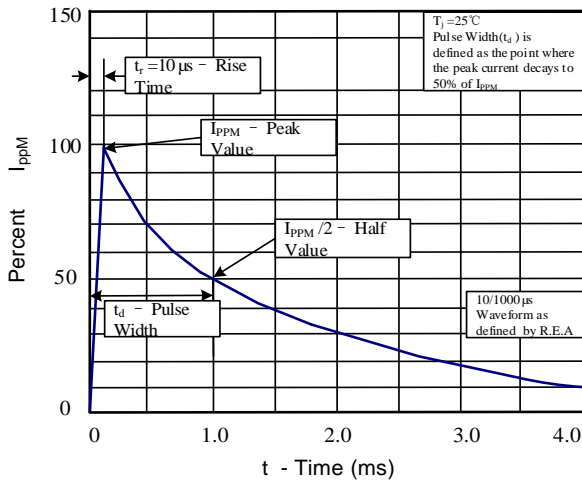

Figure 4: Typical Junction Capacitance

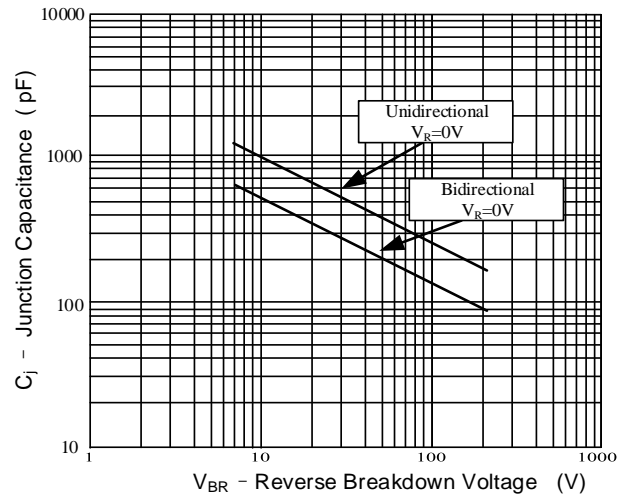

Figure 5: Steady State Power Dissipation Derating Curve

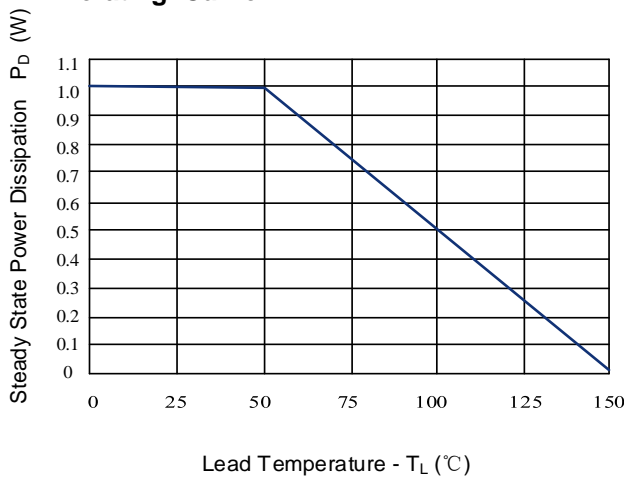
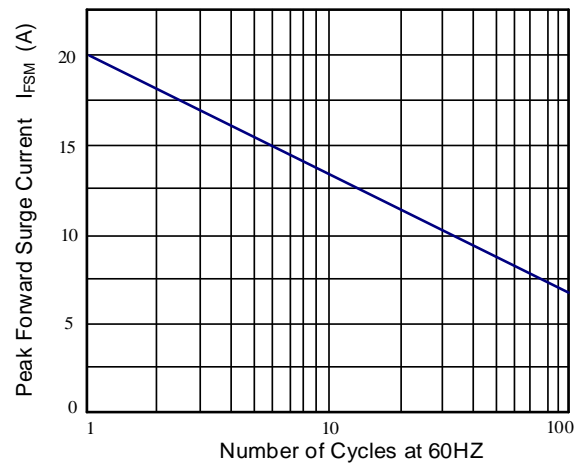
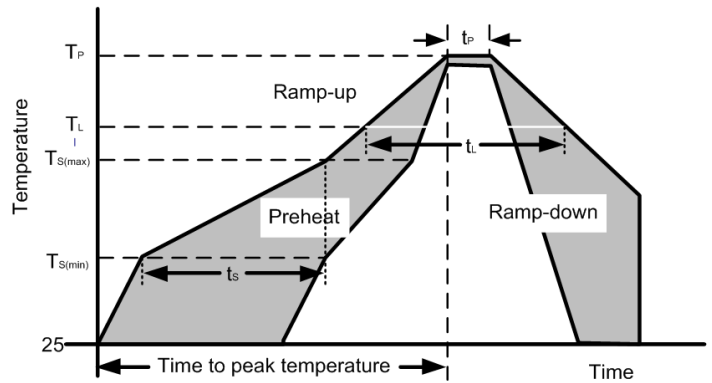

Figure 6: Maximum Non-Repetitive Forward Surge Current Only Unidirectional



Soldering Parameters

Reflow Condition		
Pre-Heat	Temperature min ($T_{s(min)}$)	150°C
	Temperature max ($T_{s(max)}$)	200°C
	Time (min to max) (t_s)	60-190 s
Average ramp up rate (Liquidus Temp (T_L) to peak)		3°C/s max
Ts(max) to T_L - Ramp-up Rate		3°C/s max
Reflow	Temperature (T_L) (Liquidus)	217°C
	Temperature (t_L)	60-150 s
Peak Temperature (T_P)		260 ^{+0/-5} °C
Time within actual peak Temperature (t_p)		20-40 s
Ramp-down Rate		5°C/s max
Time 25°C to peak Temperature (T_P)		8 minutes max
Do not exceed		260°C



Outline Drawing – SOD-123

Ref. (mm)	Millimeters	
	Min.	Max.
A	2.50	2.95
B	3.40	3.95
C	0.70	1.10
D	1.50	1.90
E	0.45	0.95
F	0.05	0.26
G	0.90	1.35

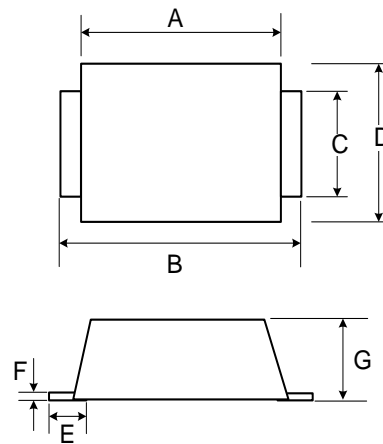

Recommended Solder Pad Layout

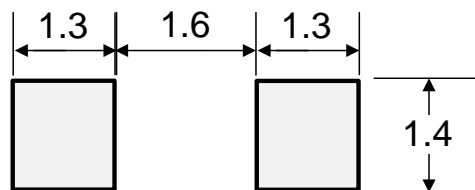

Dimensions in mm

Part Numbering System

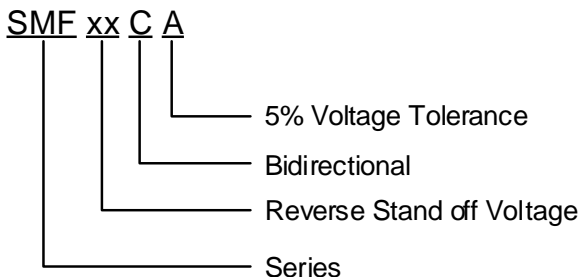

Part Marking System

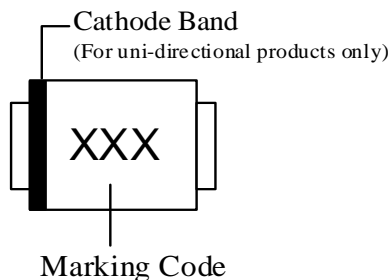

Package Information

Package Type	Description	Quantity (pcs)	Standard
SOD-123	Tape & Reel -8mm/7" tape	3000	EIA-481-D

CONTACT INFORMATION

No.1001, Shiwan(7) Road, Pudong District, Shanghai, P.R.China.201207

Tel: +86-21-68969993 Fax: 86-21-50757680 Email: market@way-on.com

WAYON website: <http://www.way-on.com>

For additional information, please contact your local Sales Representative.

WAYON® is registered trademarks of Wayon Corporation.

*Specifications are subject to change without notice.
The device characteristics and parameters in this data sheet can and do vary in different applications and actual device performance may vary over time.
Users should verify actual device performance in their specific applications.*

单击下面可查看定价，库存，交付和生命周期等信息

[>>WAY-ON\(维安\)](#)