

Transient Voltage Suppressor

Features

- 100Watts Peak Power per Line (tp = 8/20 μ s)
- Protects two I/O lines
- Low operating voltage: 5V
- Ultra Low capacitance for high-speed interfaces
- Solid-state technology

IEC COMPATIBILITY (EN61000-4)

- IEC 61000-4-2 (ESD) ± 20 kV (air), ± 20 kV (contact)
- IEC 61000-4-4 (EFT) 40A (5/50ns)
- IEC 61000-4-5 (Lightning) 5A (8/20 μ s)

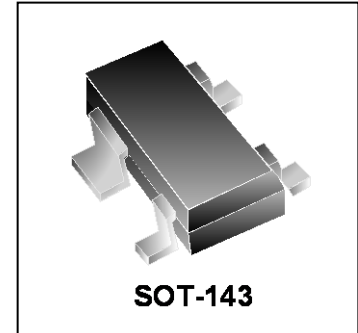

Mechanical Characteristics

- SOT-143 package
- Marking : Making Code
- Packaging : Tape and Reel per EIA 481
- RoHS Compliant

Applications

- FireWire & USB
- Sensitive Analog Inputs
- Portable Electronics
- LAN/WAN equipment
- Video Line Protection
- Microcontroller Input Protection

Circuit Diagram

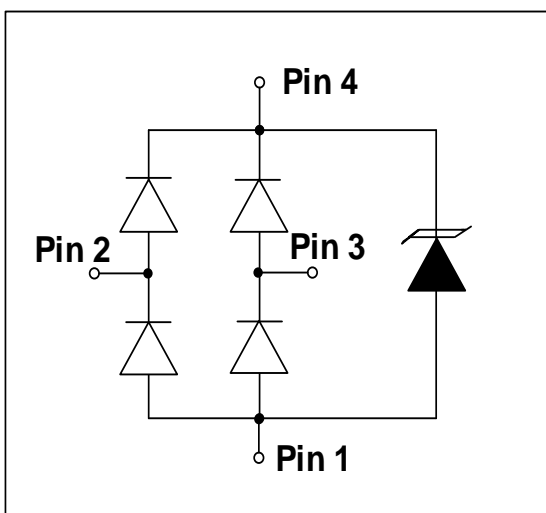

Schematic & PIN Configuration

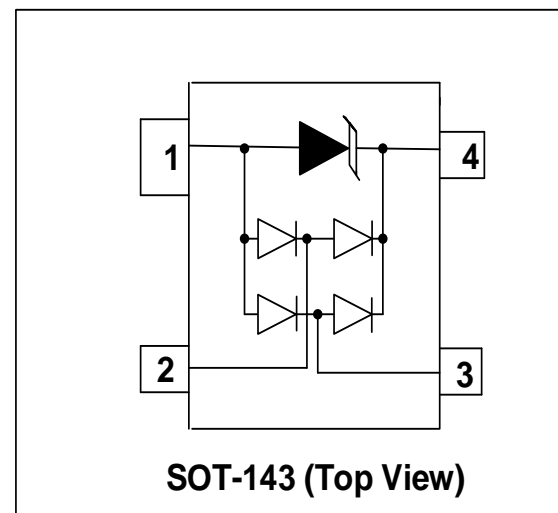

Absolute Maximum Rating			
Rating	Symbol	Value	Units
Peak Pulse Power ($t_p = 8/20\mu s$)	P_{PP}	100	Watts
Peak Pulse Current ($t_p = 8/20\mu s$)	I_{PP}	5	A
Operating Temperature	T_J	-55 to + 125	°C
Storage Temperature	T_{STG}	-55 to +150	°C

Electrical Parameters (T=25°C)

Symbol	Parameter
I_{PP}	Reverse Peak Pulse Current
V_C	Clamping Voltage @ I_{PP}
V_{RWM}	Reverse Stand-Off Voltage
I_R	Reverse Leakage Current @ V_{RWM}
V_{BR}	Breakdown Voltage @ I_T
I_T	Test Current
I_F	Forward Current
V_F	Forward Voltage @ I_F

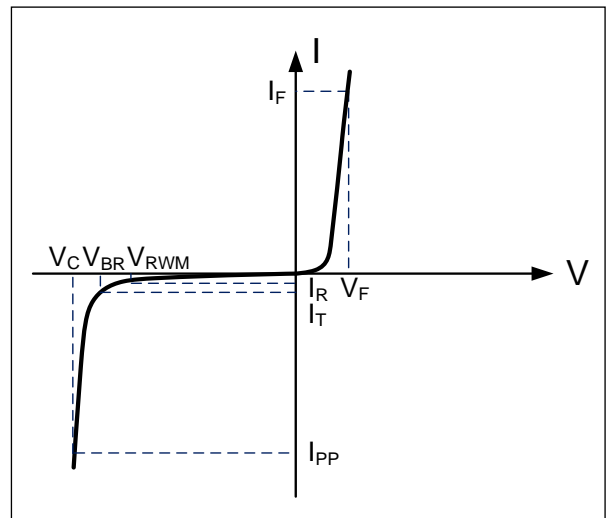

Electrical Characteristics

WE05R						
Parameter	Symbol	Conditions	Minimum	Typical	Maximum	Units
Reverse Stand-Off Voltage	V_{RWM}	Any I/O pin to ground			5	V
Reverse Breakdown Voltage	V_{BR}	$I_T = 1mA$ Any I/O pin to ground	6			V
Reverse Leakage Current	I_R	$V_{RWM} = 5V, T = 25^\circ C$ I/O pin to GND			500	nA
Clamping Voltage	V_C	$I_{PP} = 5A, t_p = 8/20\mu s$ I/O pin to GND		14	20	V
Dynamic Resistance ^{1,2}	R_{DYN}	TLP=0.2/100ns		0.69		Ω
ESD Clamping Voltage ¹	V_C	$I_{PP} = 4A,$ $t_p = 0.2/100ns$ (TLP)		10.6		V
ESD Clamping Voltage ¹	V_C	$I_{PP} = 16A,$ $t_p = 0.2/100ns$ (TLP)		18.9		V
Junction Capacitance	C_j	$V_R = 0V, f = 1MHz$ I/O pin to GND		0.8	1	pF
		$V_R = 0V, f = 1MHz$ Between I/O pins		0.4	0.6	pF

Notes : 1. TLP Setting : $t_p = 100ns, t_r = 0.2ns, I_{TLP}$ and V_{TLP} sample window: $t_1 = 70ns$ to $t_2 = 90ns$.
2. Dynamic resistance calculated from $I_{PP} = 4A$ to $I_{PP} = 16A$ using "Best Fit".

Typical Characteristics

Figure 1: Peak Pulse Power vs. Pulse Time

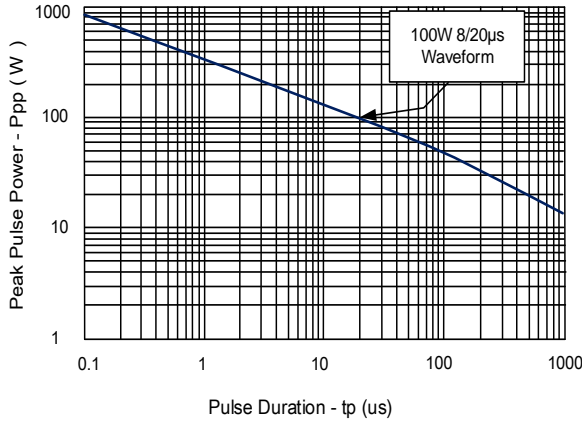

Figure 2: Power Derating curve

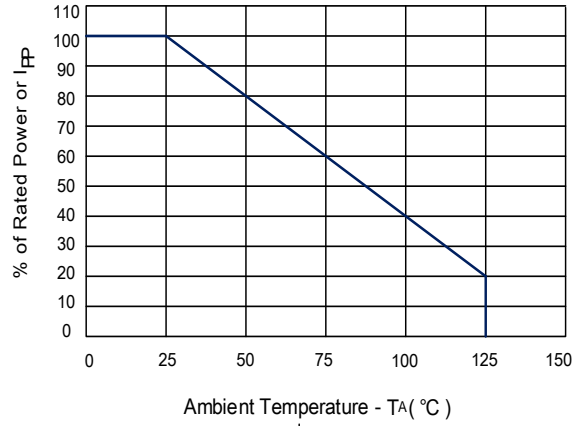

Figure 3: Clamping Voltage vs. Peak Pulse Current

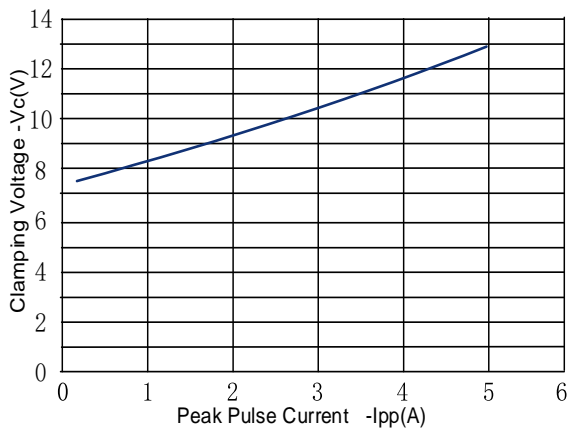

Figure 4: Normalized Junction Capacitance vs. Reverse Voltage

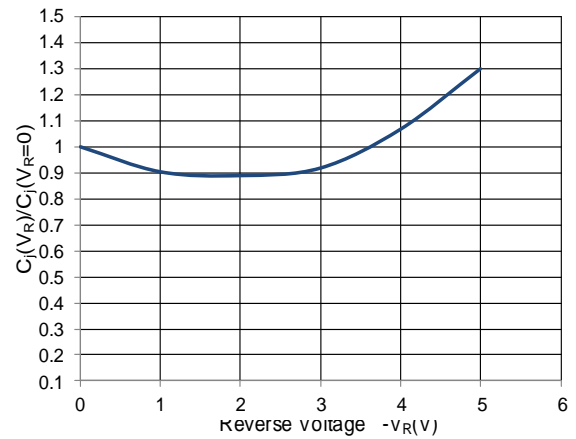

Figure 5: 8/20µs Pulse Waveform

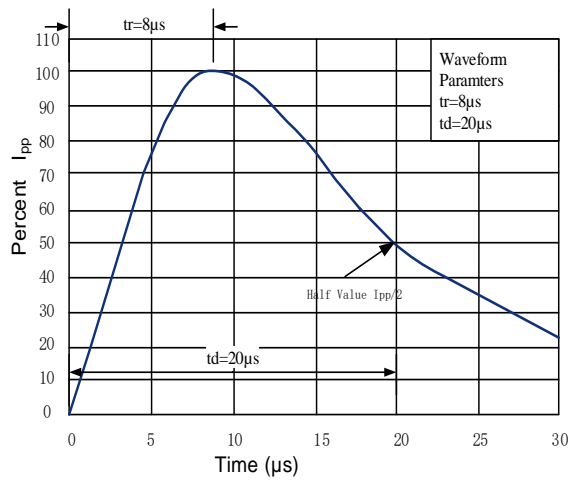
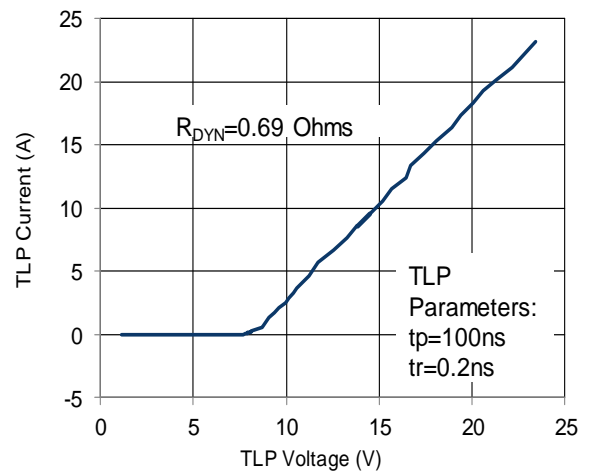
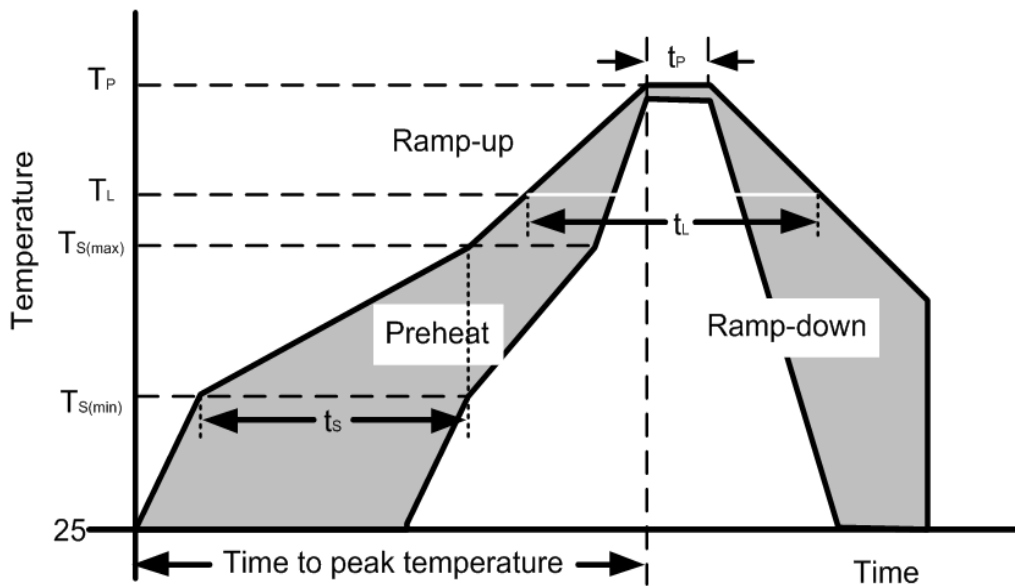

Figure 6: TLP I-V Curve



Soldering Parameters

Reflow Condition		Pb – Free assembly
Pre Heat	Temperature Min ($T_{S(min)}$)	150°C
	Temperature Max ($T_{S(max)}$)	200°C
	Time (min to max) (t_s)	60 – 190 secs
Average ramp up rate (Liquidus Temp) (T_L) to peak		5°C/second max
$T_{S(max)}$ to T_L — Ramp-up Rate		5°C/second max
Reflow	Temperature (T_L) (Liquidus)	217°C
	Temperature (t_L)	60 – 150 seconds
Peak Temperature (T_P)		260+0/-5 °C
Time within actual peak Temperature (t_p)		20 – 40 seconds
Ramp-down Rate		5°C/second max
Time 25°C to peak Temperature (T_P)		8 minutes Max.
Do not exceed		280°C



Outline Drawing – SOT-143

PACKAGE OUTLINE

SOT-143

SYMBOL	MILLIMETERS		INCHES	
	MIN	MAX	MIN	MAX
A	0.900	1.150	0.035	0.045
A1	0.000	0.100	0.000	0.004
A2	0.900	1.050	0.035	0.041
b	0.300	0.500	0.012	0.020
b1	0.750	0.900	0.030	0.035
c	0.080	0.150	0.003	0.006
D	2.800	3.000	0.110	0.118
e	1.800	2.000	0.071	0.079
e1	0.200TYP		0.008TYP	
E	2.250	2.550	0.089	0.100
E1	1.200	1.400	0.047	0.055
L1	0.550REF		0.022REF	
L	0.300	0.500	0.012	0.020
θ	0°	8°	0°	8°

DIMENSIONS		
DIM	INCHES	MILLIMETER S
C	.087	2.20
E1	.076	1.92
E2	.068	1.72
G	.031	0.80
X1	.039	1.00
X2	.047	1.20
Y	.055	1.40
Z	.141	3.60

Notes:
Controlling Dimension: Millimeter.

Marking Codes

Part Number	WE05R	Marking Code	E5R
-------------	-------	--------------	-----

Package Information

Qty: 3k/Reel

CONTACT INFORMATION

No.1001, Shiwan (7) Road, Pudong District, Shanghai, P.R.China.201207

Tel: 86-21-68969993 Fax: 86-21-50757680 Email: market@way-on.com

WAYON website: <http://www.way-on.com>

For additional information, please contact your local Sales Representative.

WAYON ® is registered trademark of Wayon Corporation.

Specifications are subject to change without notice.
The device characteristics and parameters in this data sheet can and do vary in different applications and actual device performance may vary over time.
Users should verify actual device performance in their specific applications.

单击下面可查看定价，库存，交付和生命周期等信息

[>>WAY-ON\(维安\)](#)