

## N-Channel MOSFET

### Features

- $V_{DS} = 20V$ ,  $I_D = 2.8A$   
 $R_{DS(on)} < 60m\Omega @ V_{GS} = 4.5V$   
 $R_{DS(on)} < 100m\Omega @ V_{GS} = 2.5V$
- Low Gate Charge
- Trench Power LV MOSFET Technology

### Mechanical Characteristics

- SOT-23 Package
- Marking : Making Code
- RoHS Compliant

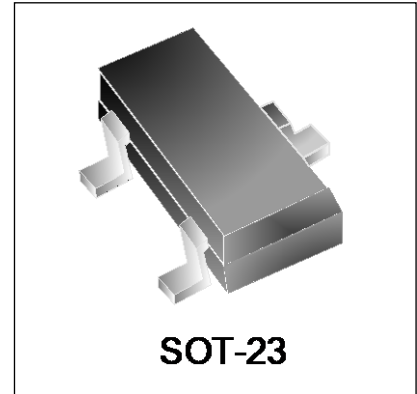

### Schematic & PIN Configuration

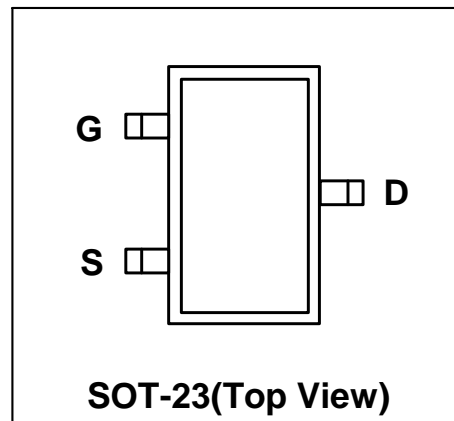
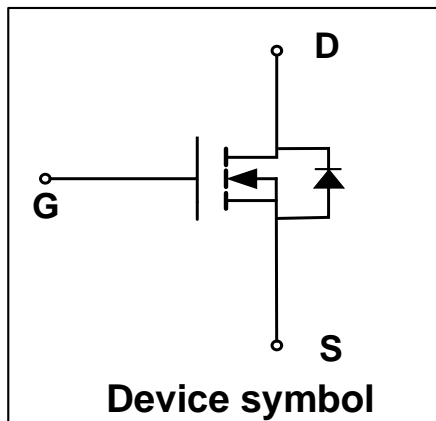

### Absolute Maximum Rating

Parameter	Symbol	Value	Unit	
Drain-Source Voltage	$V_{DS}$	20	V	
Gate-Source Voltage	$V_{GS}$	$\pm 10$	V	
Continuous Drain Current	$I_D$	$T_A = 25^\circ C$	2.8	A
		$T_A = 100^\circ C$	2.2	A
Pulsed Drain Current <sup>1</sup>	$I_{DM}$	10	A	
Power Dissipation	$P_D$	0.7	W	
Junction Temperature	$T_J$	150	$^\circ C$	
Storage Temperature	$T_{STG}$	-55 to 150	$^\circ C$	
Thermal Resistance from Junction to Ambient <sup>2</sup>	$R_{\theta JA}$	178	$^\circ C/W$	

Electrical Characteristics (T<sub>amb</sub>=25°C unless otherwise noted)

Parameter	Symbol	Test Condition	Min.	Typ.	Max.	Unit
<b>Static Characteristics</b>						
Drain-Source Breakdown Voltage	V <sub>(BR)DSS</sub>	V <sub>GS</sub> = 0 V, I <sub>D</sub> = 250μA	20	-	-	V
Zero Gate Voltage Drain Current	I <sub>DSS</sub>	V <sub>DS</sub> = 20V, V <sub>GS</sub> = 0V	-	-	1	μA
Gate-Source Leakage	I <sub>GSS</sub>	V <sub>GS</sub> = ±10V, V <sub>DS</sub> = 0V	-	-	±100	nA
Gate-Source Threshold Voltage <sup>3</sup>	V <sub>GS(th)</sub>	V <sub>GS</sub> = V <sub>DS</sub> , I <sub>D</sub> = 250μA	0.4	0.85	1.2	V
Drain-Source on-State Resistance <sup>3</sup>	R <sub>DS(on)</sub>	V <sub>GS</sub> = 4.5V, I <sub>D</sub> = 2.8A	-	40	60	mΩ
		V <sub>GS</sub> = 2.5V, I <sub>D</sub> = 2.0A	-	55	100	
<b>Dynamic Characteristics</b>						
Input Capacitance	C <sub>iss</sub>	V <sub>GS</sub> = 0V, V <sub>DS</sub> = 10V, f = 1 MHz	-	220	-	pF
Output Capacitance	C <sub>oss</sub>		-	37	-	
Reverse Transfer Capacitance	C <sub>rss</sub>		-	30	-	
<b>Switching Characteristics</b>						
Total gate charge <sup>4</sup>	Q <sub>g</sub>	V <sub>GS</sub> = 4.5V, V <sub>DS</sub> = 10V, I <sub>D</sub> = 2.5A	-	2.6	-	nC
Gate-source charge <sup>4</sup>	Q <sub>gs</sub>		-	0.5	-	
Gate-drain charge <sup>4</sup>	Q <sub>gd</sub>		-	0.7	-	
Turn-on Time <sup>4</sup>	t <sub>d(on)</sub>	V <sub>GS</sub> = 4.5V, V <sub>DD</sub> = 10V, R <sub>L</sub> = 1.5Ω, R <sub>GEN</sub> = 3Ω	-	12.5	-	nS
Rise Time <sup>4</sup>	t <sub>r</sub>		-	9.8	-	
Turn-off Time <sup>4</sup>	t <sub>d(off)</sub>		-	17.5	-	
Fall Time <sup>4</sup>	t <sub>f</sub>		-	5	-	
<b>Source-Drain Diode Characteristics</b>						
Body Diode Voltage	V <sub>SD</sub>	I <sub>S</sub> = 1A, V <sub>GS</sub> = 0V	-	-	1.2	V

**Notes:**

1. Repetitive Rating: Pulse width limited by maximum junction temperature.
2. Surface mounted on FR4 board using 1 square inch pad size, 1oz single-side copper.
3. Pulse Test: Pulse width ≤ 300μs, duty cycle ≤ 2%.
4. Guaranteed by design, not subject to product

Typical Characteristics

Figure 1. Output Characteristics

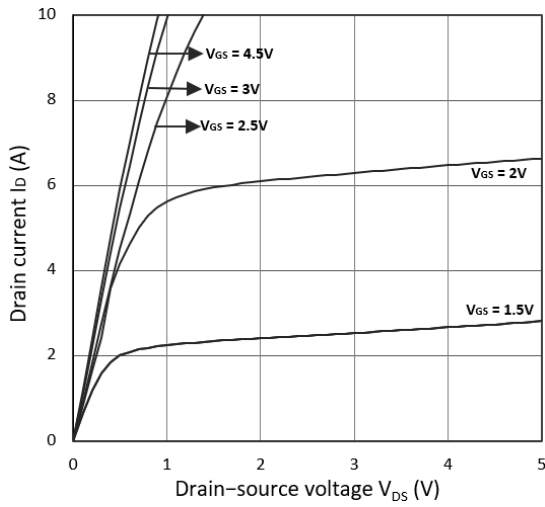

Figure 2. Transfer Characteristics

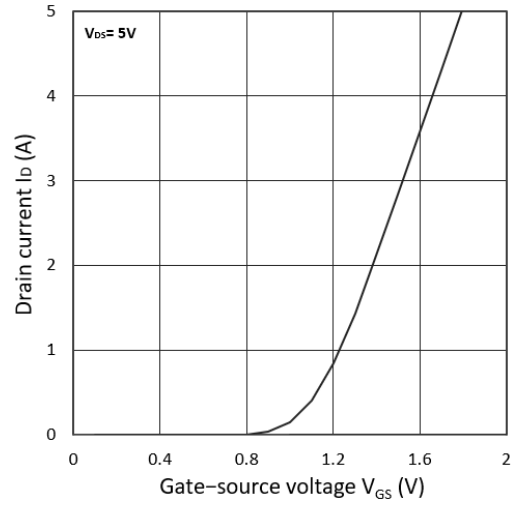

Figure 3.  $R_{DS(on)}$  vs.  $I_D$

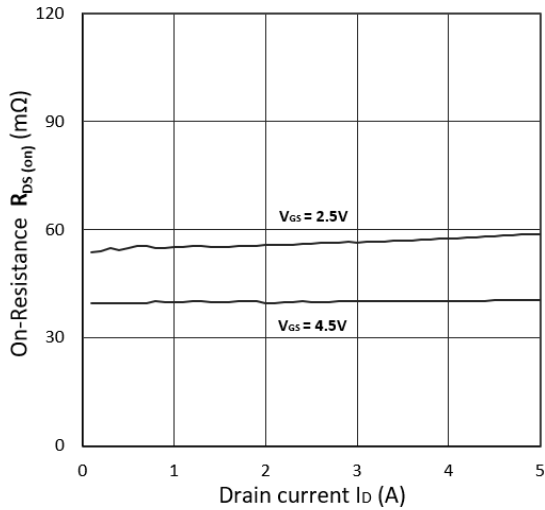

Figure 4.  $R_{DS(on)}$  vs.  $V_{GS}$

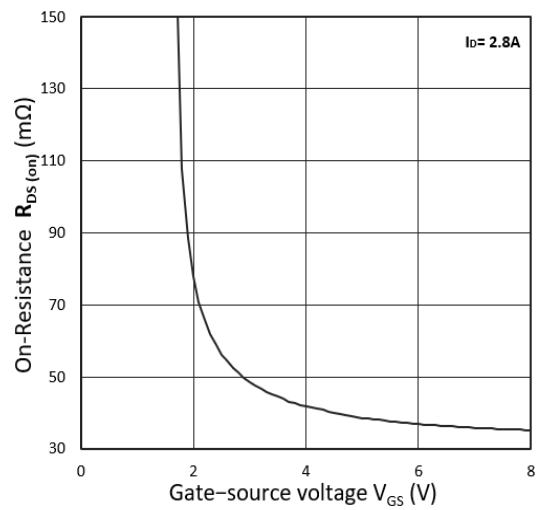

Figure 5.  $I_S$  vs.  $I_D$

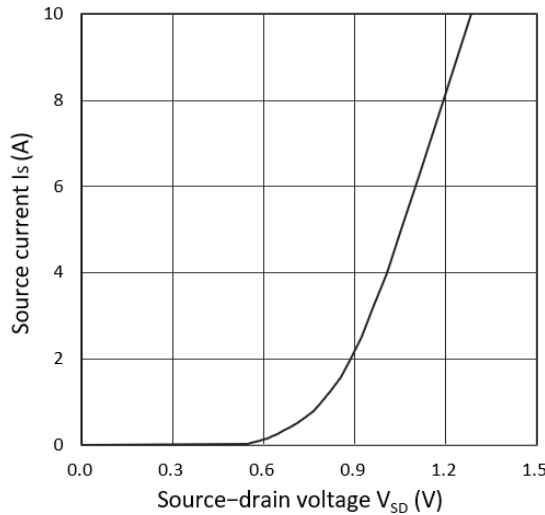
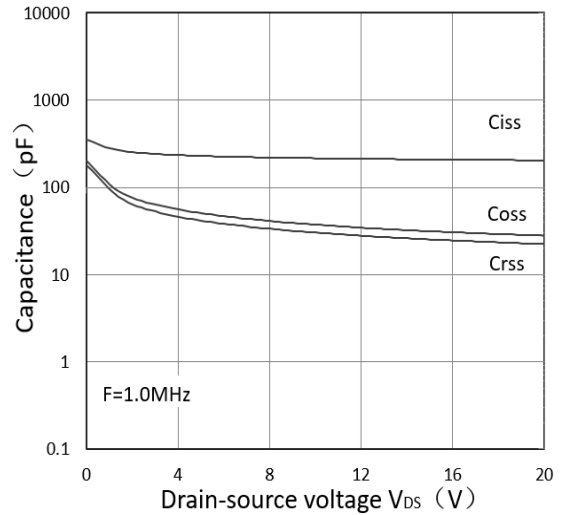

Figure 6. Capacitance Characteristics



Outline Drawing – SOT-23

### PACKAGE OUTLINE

**SOT-23**

SYMBOL	MILLIMETER		INCHES	
	MIN	MAX	MIN	MAX
A	0.90	1.15	0.035	0.045
A1	0.00	0.10	0.000	0.004
b	0.30	0.50	0.012	0.020
c	0.08	0.15	0.003	0.006
D	2.80	3.00	0.110	0.118
E	2.25	2.55	0.089	0.100
E1	1.20	1.40	0.047	0.055
e	0.95 BSC		0.0374 BSC	
e1	1.80	2.00	0.071	0.079
L	0.45	0.65	0.018	0.026
θ	0°	8°	0°	8°

DIMENSIONS		
DIM	INCHES	MILLIMETERS
M	0.080	2.02
C	0.032	0.80
Z	0.111	2.82
e	0.037 BSC	0.95 BSC
e1	0.075 BSC	1.9 BSC
b	0.032	0.80

**Notes**

1. Dimensioning and tolerances per ANSI Y14.5M, 1985.
2. Controlling Dimension: Inches
3. Pin 3 is the cathode (Unidirectional Only).
4. Dimensions are exclusive of mold flash and metal burrs.

Marking Codes

Part Number	WM02N28M
Marking Code	

Package Information

Qty: 3k/Reel

CONTACT INFORMATION

No.1001, Shiwan (7) Road, Pudong District, Shanghai, P.R.China.201207

Tel: 86-21-68969993 Fax: 86-21-50757680 Email: [market@way-on.com](mailto:market@way-on.com)

WAYON website: <http://www.way-on.com>

For additional information, please contact your local Sales Representative.

**WAYON**® is registered trademark of Wayon Corporation.

Specifications are subject to change without notice.  
The device characteristics and parameters in this data sheet can and do vary in different applications and actual device performance may vary over time.  
Users should verify actual device performance in their specific applications.

单击下面可查看定价，库存，交付和生命周期等信息

[>>WAY-ON\(维安\)](#)