



GDTN2RS8A-XX

Gas Discharge Tube

Features

- 2-electrode arrester
- Very small size
- Extremely fast response time
- Stable performance over life
- Extremely low capacitance (<1.5pF)
- High insulation resistance



Application

- Modem
- Splitter
- Base stations
- PCI cards
- Application with limited space

Electrical specifications

Part number	DC Spark-over Voltage ^{1) 2)}	Maximum Impulse Spark-over Voltage	Service Life ³⁾	Insulation resistance	Capacitance	Marking Code
		1kv/ μ s	8/20 μ s 10times	@ 100V _{DC}	@ 1 MHz	
	(V)	(V)	(KA)	(G Ω)	(pF)	
GDTN2RS8A-75	75 \pm 30%	600	20KA	> 1@50V _{DC}	< 1.5	None
GDTN2RS8A-90	90 \pm 30%	600	20KA	> 1@50V _{DC}	< 1.5	None
GDTN2RS8A-150	150 \pm 20%	600	20KA	> 1	< 1.5	None
GDTN2RS8A-230	230 \pm 20%	700	20KA	> 1	< 1.5	None
GDTN2RS8A-300	350 \pm 20%	900	20KA	> 1	< 1.5	None
GDTN2RS8A-350	420 \pm 20%	950	20KA	> 1	< 1.5	None
GDTN2RS8A-400	470 \pm 20%	1000	20KA	> 1	< 1.5	None
GDTN2RS8A-470	600 \pm 20%	1100	20KA	> 1	< 1.5	None
GDTN2RS8A-600	800 \pm 20%	1300	20KA	> 1	< 1.5	None

1) At delivery AQL 0.65 level II, DIN ISO 2859.

2) In ionized mode.

3) Tests according to ITU-T Rec. K. 12 and UL 497B.

Terms and current waveforms in accordance with: ITU-T Rec. K.12; IEC 61643-21 and DIN 57845/VDE0845.

Thermal Resistances

Symbol	Parameter	Value	Unit
T _s & T _j	Storage & Operating temperature range	-40 to +85	°C

Soldering Parameters

Reflow Condition		Pb – Free assembly
Pre Heat	Temperature Min (T _{s(min)})	150°C
	Temperature Max (T _{s(max)})	200°C
	Time (min to max) (t _s)	60 – 190 secs
Average ramp up rate (Liquidus Temp) (T _L) to peak		5°C/second max
T _{s(max)} to T _L — Ramp-up Rate		5°C/second max
Reflow	Temperature (T _L) (Liquidus)	217°C
	Temperature (t _L)	60 – 150 seconds
Peak Temperature (T _P)		260 ^{+0/-5} °C
Time within actual peak Temperature (t _p)		20 – 40 seconds
Ramp-down Rate		5°C/second max
Time 25°C to peak Temperature (T _P)		8 minutes Max.
Do not exceed		260°C

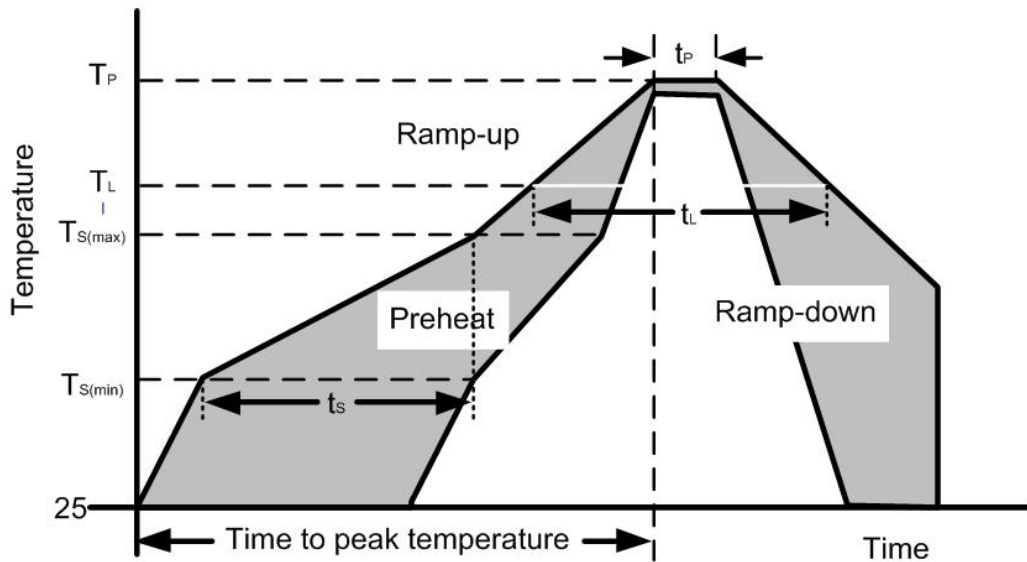

Dimensional drawing

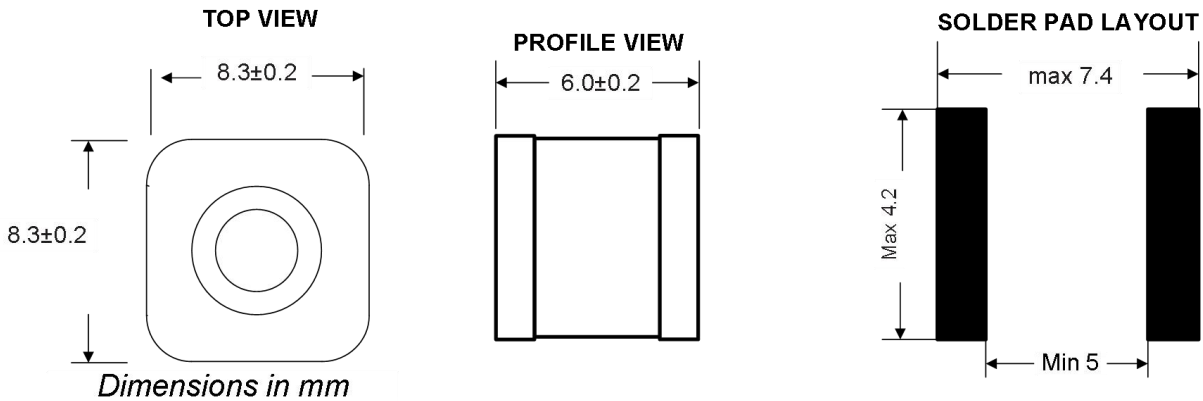

Cautions and warnings

- Surge arresters must not be operated directly in power supply networks.
- Surge arresters may become hot in case of longer periods of current stress (danger of burning).
- Surge arresters may be used only within their specified values. In case of overload, the headcontacts may fail or the component may be destroyed.
- Damaged surge arresters must not be re-used.

Part Numbering System

GDT N 2R S8A - XX

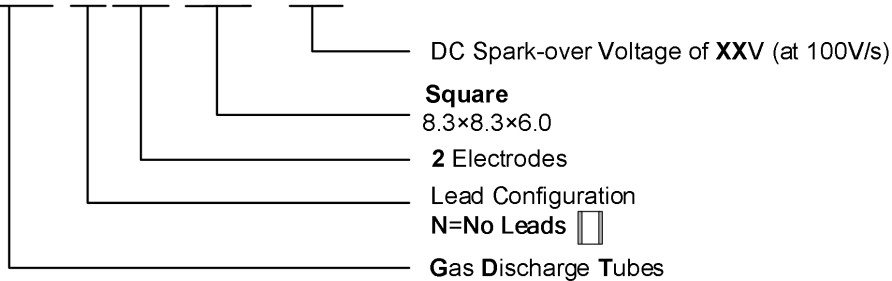

Package Information

Tape and Reel: 400 Pcs/Reel .

Contact Information

No.1001, Shiwan(7) Road, Pudong District, Shanghai, P.R.China.201207

Tel: 86-21-68969993 Fax: 86-21-50757680 Email: market@way-on.com

WAYON website: <http://www.way-on.com>

For additional information, please contact your local Sales Representative.

WAYON ® are registered trademarks of Wayon Corporation.

*Specifications are subject to change without notice.
 The device characteristics and parameters in this data sheet can and do vary in different applications and actual device performance may vary over time.
 Users should verify actual device performance in their specific applications.*

单击下面可查看定价，库存，交付和生命周期等信息

[>>WAY-ON\(维安\)](#)