

PNP Silicon Transistor

Features

- Switching Transistor
- Collector Current: $I_C = -0.6A$

Mechanical Characteristics

- SOT-23 Package
- Marking : Making Code
- RoHS Compliant

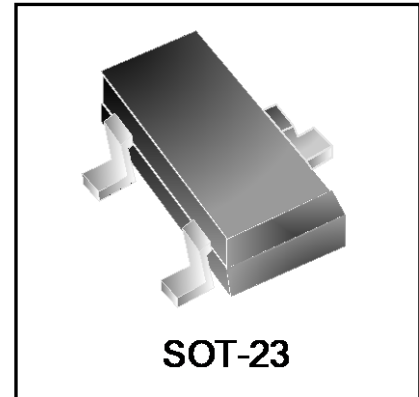

Schematic & PIN Configuration

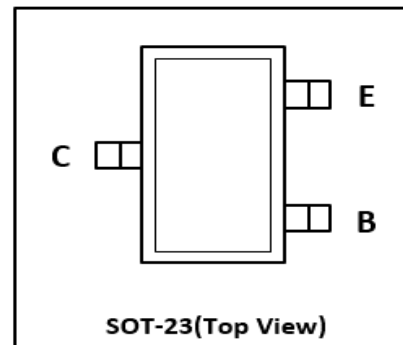
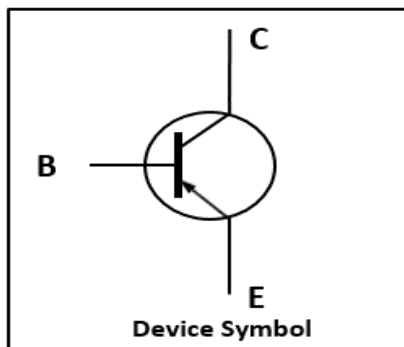
Absolute Maximum Rating ($T_{amb}=25^{\circ}C$ unless otherwise specified)

| Parameter | Symbol | Value | Unit |
|---|-----------------|-----------|---------------|
| Collector Base Voltage | V_{CBO} | -40 | V |
| Collector Emitter Voltage | V_{CEO} | -40 | V |
| Emitter Base Voltage | V_{EBO} | -5 | V |
| Collector Current | I_C | -0.6 | A |
| Collector Power Dissipation | P_C | 300 | mW |
| Thermal Resistance From Junction To Ambient | $R_{\theta JA}$ | 417 | $^{\circ}C/W$ |
| Junction Temperature | T_j | 150 | $^{\circ}C$ |
| Storage Temperature | T_{stg} | -55 ~ 150 | $^{\circ}C$ |

Electrical Characteristics ($T_{amb}=25^{\circ}\text{C}$ unless otherwise specified)

| Parameter | Symbol | Test Conditions | Min. | Typ. | Max. | Unit |
|--------------------------------------|---------------|--|------|------|-------|------|
| Collector-base breakdown voltage | $V_{(BR)CBO}$ | $I_C = -100\mu\text{A}, I_E = 0$ | -40 | - | - | V |
| Collector-emitter breakdown voltage | $V_{(BR)CEO}$ | $I_C = -1\text{mA}, I_B = 0$ | -40 | - | - | V |
| Emitter-base breakdown voltage | $V_{(BR)EBO}$ | $I_E = -100\mu\text{A}, I_C = 0$ | -5 | - | - | V |
| Collector cut-off current | I_{CBO} | $V_{CB} = -35\text{V}, I_E = 0$ | - | - | -100 | nA |
| Collector cut-off current | I_{CEX} | $V_{CE} = -35\text{V}, V_{BE} = -0.4\text{V}$ | - | - | -100 | nA |
| Emitter cut-off current | I_{EBO} | $V_{EB} = -4\text{V}, I_C = 0$ | - | - | -100 | nA |
| DC current gain | $h_{FE(1)}$ | $V_{CE} = -1\text{V}, I_C = -0.1\text{mA}$ | 30 | - | - | - |
| | $h_{FE(2)}$ | $V_{CE} = -1\text{V}, I_C = -1\text{mA}$ | 60 | - | - | - |
| | $h_{FE(3)}$ | $V_{CE} = -1\text{V}, I_C = -10\text{mA}$ | 100 | - | - | - |
| | $h_{FE(4)}$ | $V_{CE} = -2\text{V}, I_C = -150\text{mA}$ | 100 | - | 300 | - |
| | $h_{FE(5)}$ | $V_{CE} = -2\text{V}, I_C = -500\text{mA}$ | 20 | - | - | - |
| Collector-emitter saturation voltage | $V_{CE(sat)}$ | $I_C = -150\text{mA}, I_B = -15\text{mA}$ | - | - | -0.4 | V |
| | | $I_C = -500\text{mA}, I_B = -50\text{mA}$ | - | - | -0.75 | V |
| Base-emitter saturation voltage | $V_{BE(sat)}$ | $I_C = -150\text{mA}, I_B = -15\text{mA}$ | - | - | -0.95 | V |
| | | $I_C = -500\text{mA}, I_B = -50\text{mA}$ | - | - | -1.3 | V |
| Transition frequency | f_T | $V_{CE} = -10\text{V}, I_C = -20\text{mA}, f = 100\text{MHz}$ | 200 | - | - | MHz |
| Delay time | t_d | $V_{CC} = -30\text{V}, V_{BE(off)} = -0.5\text{V}$ $I_C = -150\text{mA}, I_{B1} = -15\text{mA}$ | - | - | 15 | ns |
| Rise time | t_r | | - | - | 20 | ns |
| Storage time | t_s | $V_{CC} = -30\text{V}, I_C = -150\text{mA}$ $I_{B1} = I_{B2} = -15\text{mA}$ | - | - | 225 | ns |
| Fall time | t_f | | - | - | 60 | ns |

Typical Characteristics

Figure 1. Static Characteristics

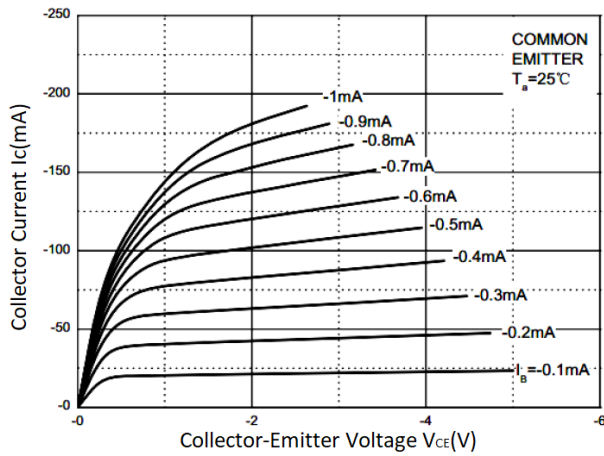

Figure 3. $V_{BE(sat)}$ vs. I_c

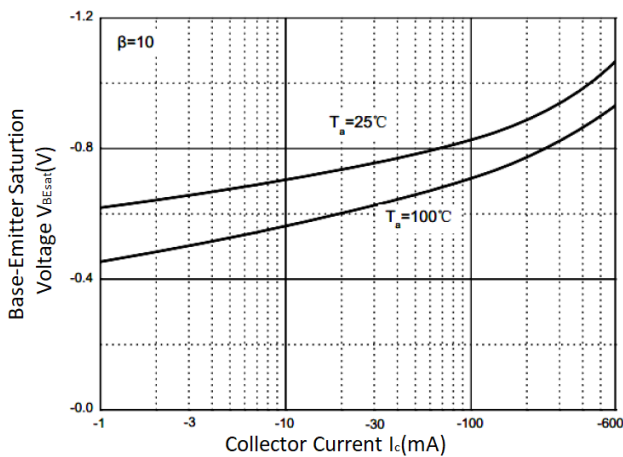

Figure 5. I_c vs. V_{BE}

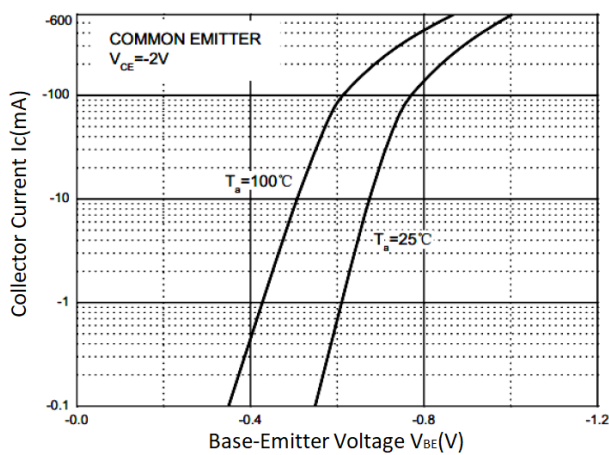

Figure 2. h_{FE} vs. I_c

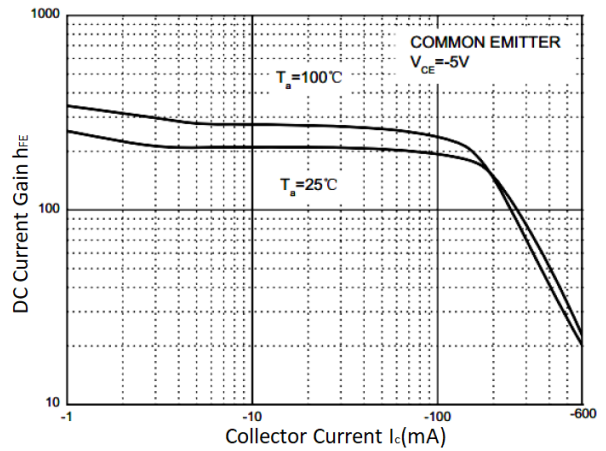

Figure 4. $V_{CE(sat)}$ vs. I_c

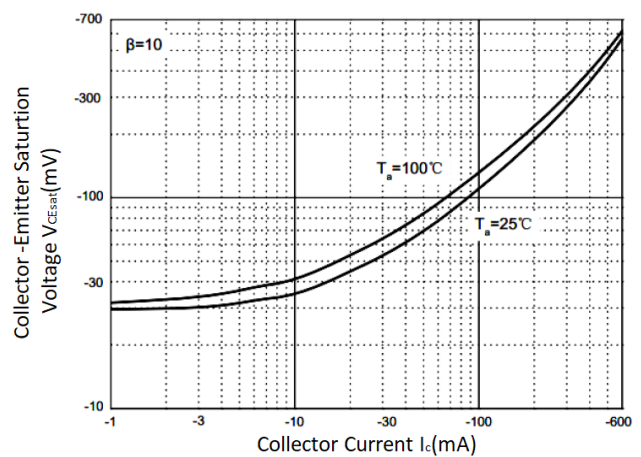

Figure 6. f_T vs. I_c

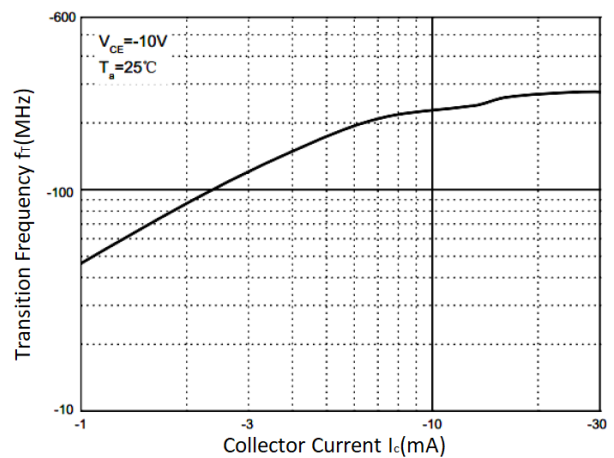

Figure 7. C_{ob} / C_{ib} vs. V_{CB} / V_{EB}

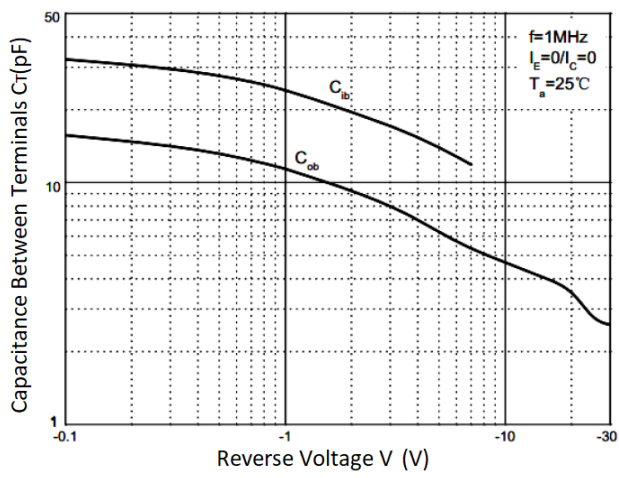
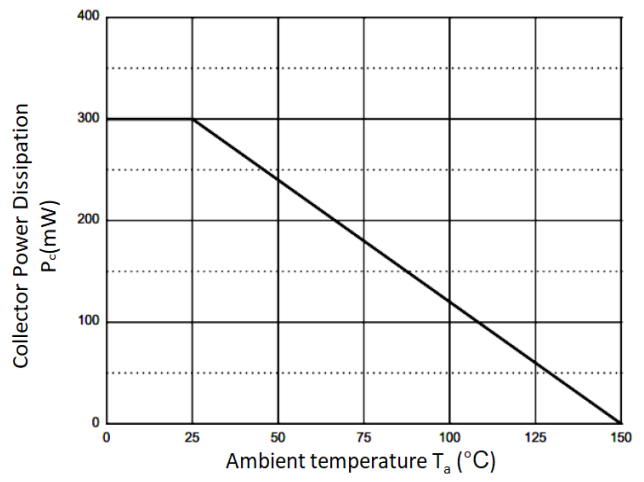

Figure 8. P_C vs. T_a



Outline Drawing – SOT-23

PACKAGE OUTLINE

SOT-23

| SYMBOL | MILLIMETER | | INCHES | |
|--------|------------|------|------------|--------|
| | MIN | MAX | MIN | MAX |
| A | 0.90 | 1.15 | 0.035 | 0.045 |
| A1 | 0.00 | 0.10 | 0.000 | 0.004 |
| A2 | 0.60 | 0.70 | 0.0236 | 0.0275 |
| b | 0.30 | 0.50 | 0.012 | 0.020 |
| c | 0.08 | 0.15 | 0.003 | 0.006 |
| D | 2.80 | 3.00 | 0.110 | 0.118 |
| E | 2.25 | 2.55 | 0.089 | 0.100 |
| E1 | 1.20 | 1.40 | 0.047 | 0.055 |
| e | 0.95 BSC | | 0.0374 BSC | |
| e1 | 1.80 | 2.00 | 0.071 | 0.079 |
| L | 0.45 | 0.65 | 0.018 | 0.026 |
| θ | 0 | 8° | 0 | 8° |

| DIMENSIONS | | |
|------------|-----------|-------------|
| DIM | INCHES | MILLIMETERS |
| M | 0.0795 | 2.02 |
| C | 0.0315 | 0.80 |
| Z | 0.111 | 2.82 |
| e | 0.037 BSC | 0.95 BSC |
| e1 | 0.075 BSC | 1.9 BSC |
| b | 0.0315 | 0.80 |

Notes

1. Dimensioning and tolerances per ANSI Y14.5M, 1985.
2. Controlling Dimension: Inches
3. Pin 3 is the cathode (Unidirectional Only).
4. Dimensions are exclusive of mold flash and metal burrs.

Marking Codes

| | |
|--------------|--------|
| Part Number | WT4403 |
| Marking Code | |

Package Information

Qty: 3k/Reel

CONTACT INFORMATION

No.1001, Shiwan (7) Road, Pudong District, Shanghai, P.R.China.201207

Tel: 86-21-68969993 Fax: 86-21-50757680 Email: market@way-on.com

WAYON website: <http://www.way-on.com>

For additional information, please contact your local Sales Representative.

WAYON® is registered trademark of Wayon Corporation.

Specifications are subject to change without notice.
The device characteristics and parameters in this data sheet can and do vary in different applications and actual device performance may vary over time.
Users should verify actual device performance in their specific applications.

单击下面可查看定价，库存，交付和生命周期等信息

[>>WAY-ON\(维安\)](#)