

● 1. General Description

The WP25142T3-B is a current limited P-channel MOSFET power switch designed for high-side load switching applications. This switch operates with inputs ranging from 2.5V to 5.5V, making it ideal for both 3.3V and 5V systems. An integrated current-limiting circuit protects the input supply against large currents which may cause the supply to fall out of regulation. The WP25142T3-B includes thermal shutdown protection that prevents damage to the device when a continuous over-current condition causes excessive heating by turning off the switch. The load of the switch can be up to 1.4A. The quiescent current is only 28 μ A.

The WP25142T3-B is available in Pb-free packages and is characterized for operation over the free-air temperature range of - 40°C to 85°C.

● 2. Features

- Input Voltage Range: 2.5V to 5.5V
- 2A Current Limit
- Reverse Current Blocking
- Short-Circuit Response: 2 μ s
- Very Low Quiescent Current: 28 μ A (Typ.)
- Under-Voltage Lockout
- Thermal Shutdown
- 8kV ESD Rating
- Package: SOT23-3

● 3. Applications

- Laptop/Desktop Computers and Netbooks
- 3G Wireless Cards
- Smart Phones and PDAs
- LCD TVs and Monitors
- Set-Top-Boxes
- MP3/MP4
- Printers
- Portable Game Players
- Portable Media Players and MIDs
- USB Keyboards
- USB Hard Disk Drives
- USB Memory Drives
- USB Hubs

● **4. Typical Application**

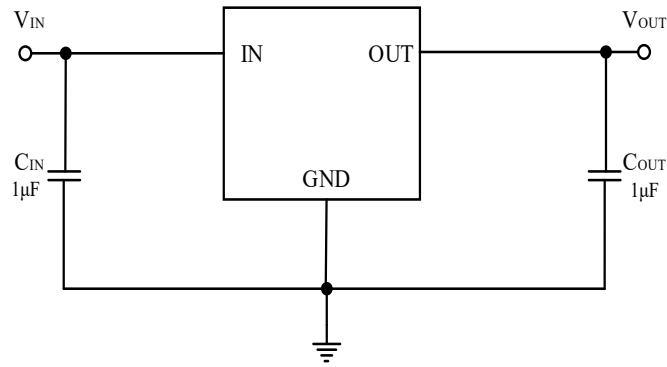

Note: Tantalum or Aluminum Electrolytic capacitors (C_{IN} and C_{OUT}) may be required for USB applications

● **5. Pin Configuration**

(Top View)

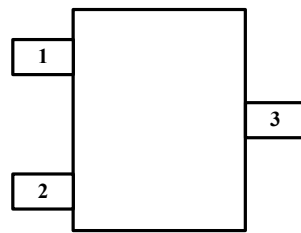

SOT23-3

● **6. Pin Description**

PIN NUMBER	PIN NAME	I/O	PIN FUNCTION
1	GND		Common ground.
2	OUT	O	Switch output.
3	IN	I	Switch input.

● 7. Absolute Maximum Ratings

Over operating free-air temperature range (unless otherwise noted)⁽¹⁾

PARAMETER	RATING	UNIT
IN Voltage	-0.3 to 6	V
OUT Voltage	-0.3 to $V_{IN} + 0.3$	V
OUT Current	Internal Limited	A
Power Dissipation	300	mW
Package Thermal Resistance(θ_{JA})	250	°C/W
Operating Junction Temperature	-40 to 125	°C
Storage Temperature	-55 to 150	°C
Lead Temperature (Soldering, 10 sec)	260	°C
ESD(HBM)	8000	V

NOTE: Stresses beyond those listed under Absolute Maximum Ratings may cause permanent damage to the device. These are stress ratings only, which do not imply functional operation of the device at these or any other conditions beyond those indicated under Recommended Operating Conditions. Exposure to absolute-maximum-rated conditions for extended periods may affect device reliability.

● 8. Recommended Operating Conditions

SYMBOL	PARAMETER	MIN	MAX	UNIT
V_{IN}	Input Voltage	2.5	5.5	V
I_{OUT}	Output Current		1.4	A
T_A	Operating Ambient Temperature	-40	85	°C

● 9. Electrical Characteristics

($V_{IN} = 5\text{ V}$, $C_{IN}=1\mu\text{F}$, $C_{OUT}=1\mu\text{F}$, $T_A=25^\circ\text{C}$, unless otherwise noted)

SYMBOL	PARAMETER	TEST CONDITIONS	MIN	TYP.	MAX	UNIT
I_Q	Quiescent Current	Enabled, OUT floating		28	60	μA
$R_{DS(ON)}$	Switch on-resistance	$V_{IN}=5\text{V}$, $I_{OUT}=0.6\text{A}$		70	120	$\text{m}\Omega$
I_{LIM}	Current Limit	$V_{IN}=5\text{V}$, $V_{OUT}=4.5\text{V}$	1.6	2	2.4	A
V_{UVLO}	Input UVLO Threshold	Enabled, V_{IN} rising	1.4	1.8	2.2	V
V_{UVLO_HYS}	Input UVLO Hysteresis			0.1		V
I_{REV}	Reverse Leakage Current	$V_{IN} = 0\text{V}$, $V_{OUT} = 5\text{V}$, I_{REV} at V_{IN}		0.1	1	μA
t_R	Output Turn-on Rise Time	$R_{LOAD}=100\Omega$	0.2	0.4	0.8	ms
T_{SHDN}	Thermal Shutdown Threshold	Note 1		150		$^\circ\text{C}$
T_{HYS}	Thermal shutdown hysteresis	Note 1		20		$^\circ\text{C}$

Note 1: Guaranteed by design.

10. Typical Performance Characteristics

($V_{IN} = 5V$, $V_{EN} = 5V$, $C_{IN}=1\mu F$, $C_{OUT}=1\mu F$, $T_A=25^\circ C$, unless otherwise noted)

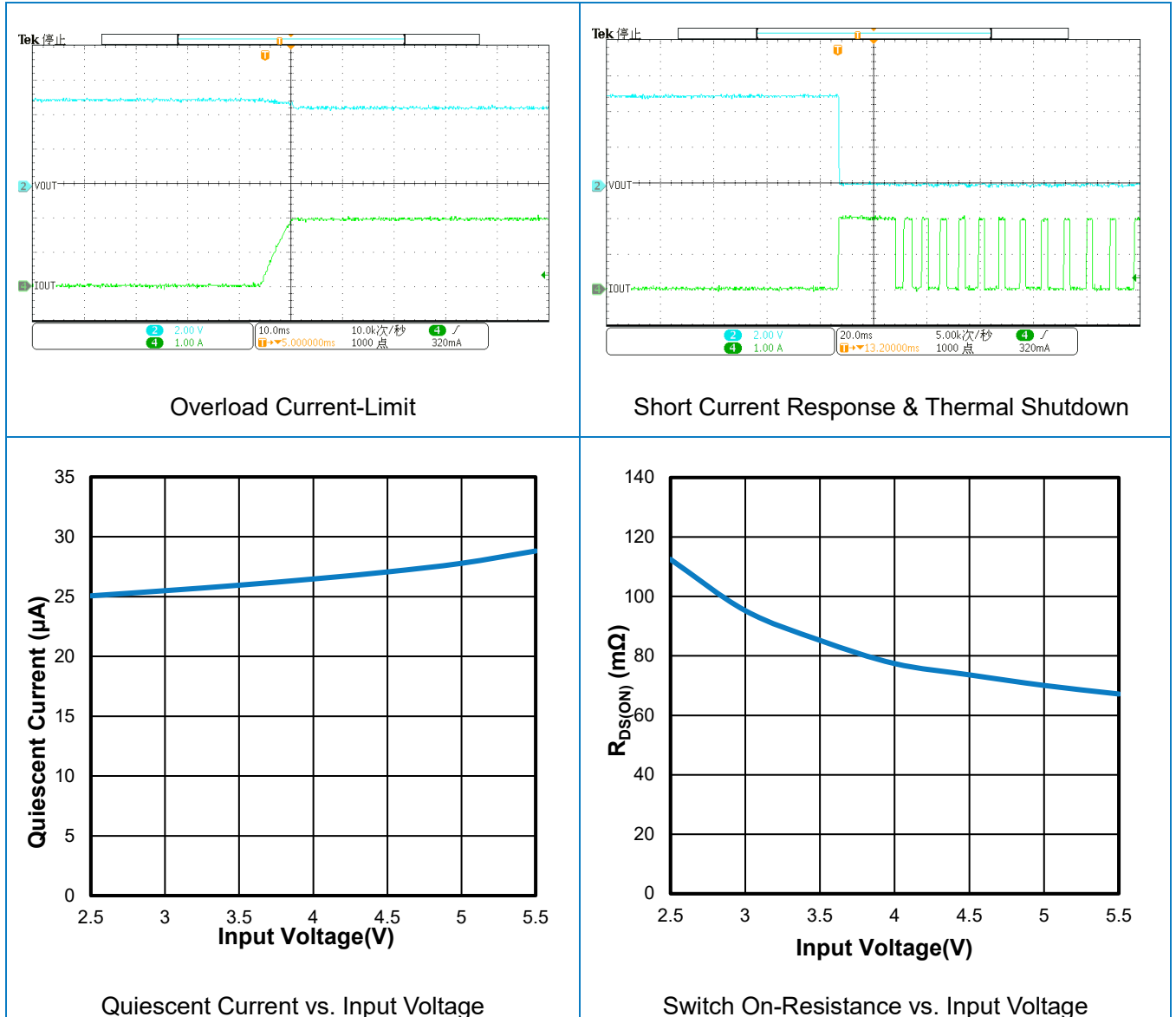

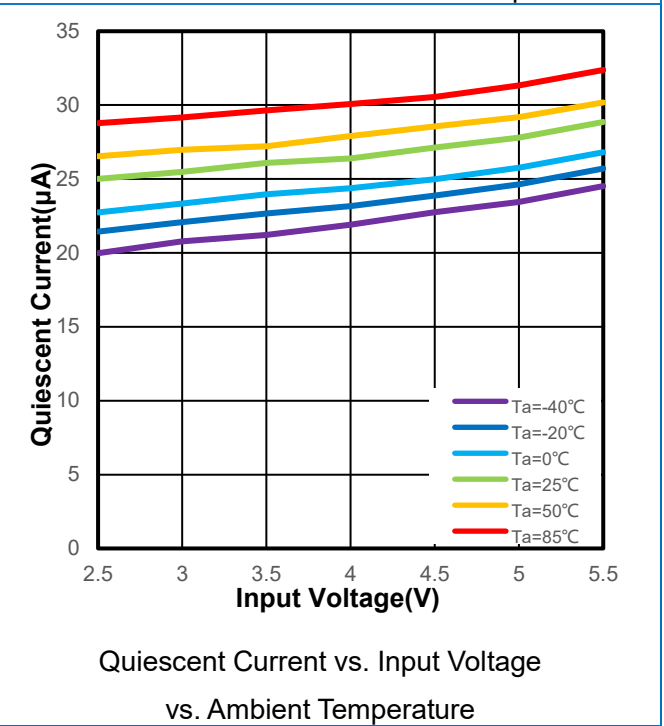
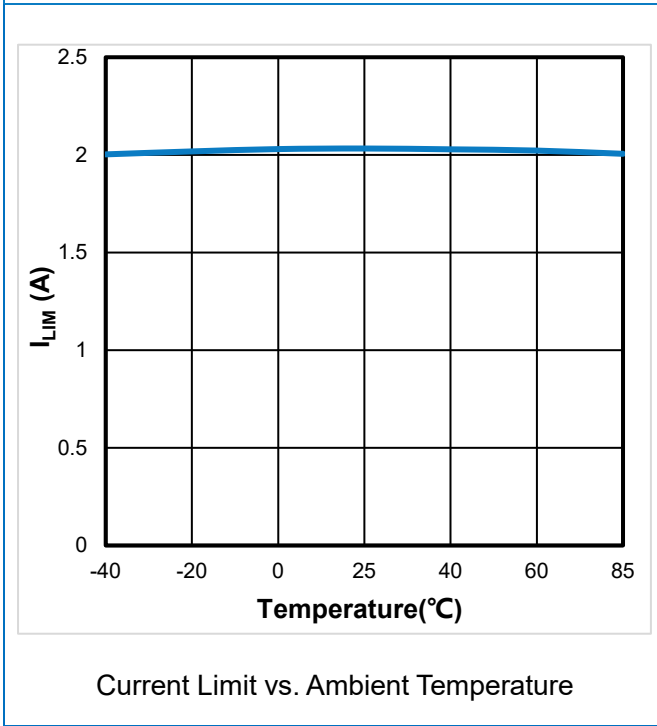
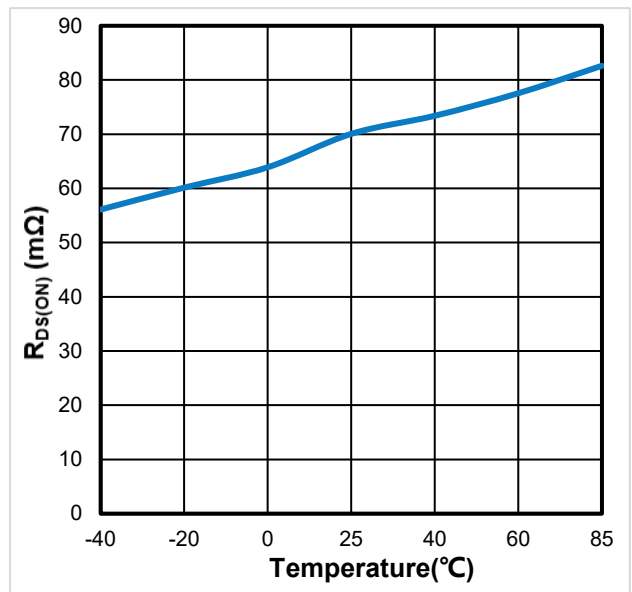
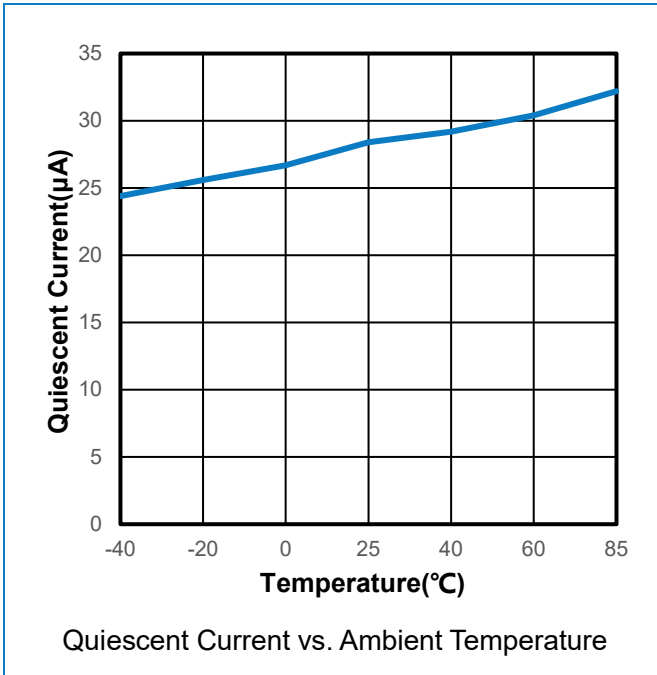

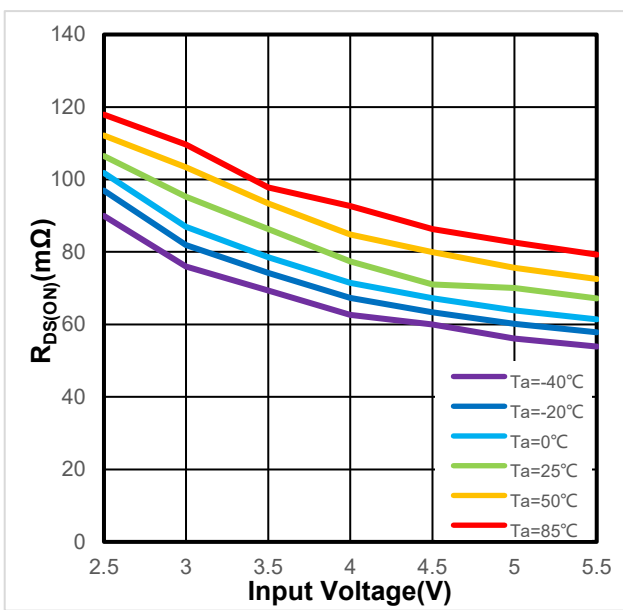

Switch On-Resistance vs. Input Voltage
vs. Ambient Temperature

● **11. Function Description**

● **11.1 Overview**

The WP25142T3-B load switches are 5.5V, current limited load switches in a SOT23-3 package. The devices contain a 70 mΩ current-limited P-channel MOSFET that can operate over an input voltage range of 2.5 V to 5.5V. When the switch current reaches the maximum limit, the WP25142T3-B operates in a constant-current mode to prohibit excessive currents from causing damage. WP25142T3-B has a current limit of 2 A.

● **11.2 Block Diagram**

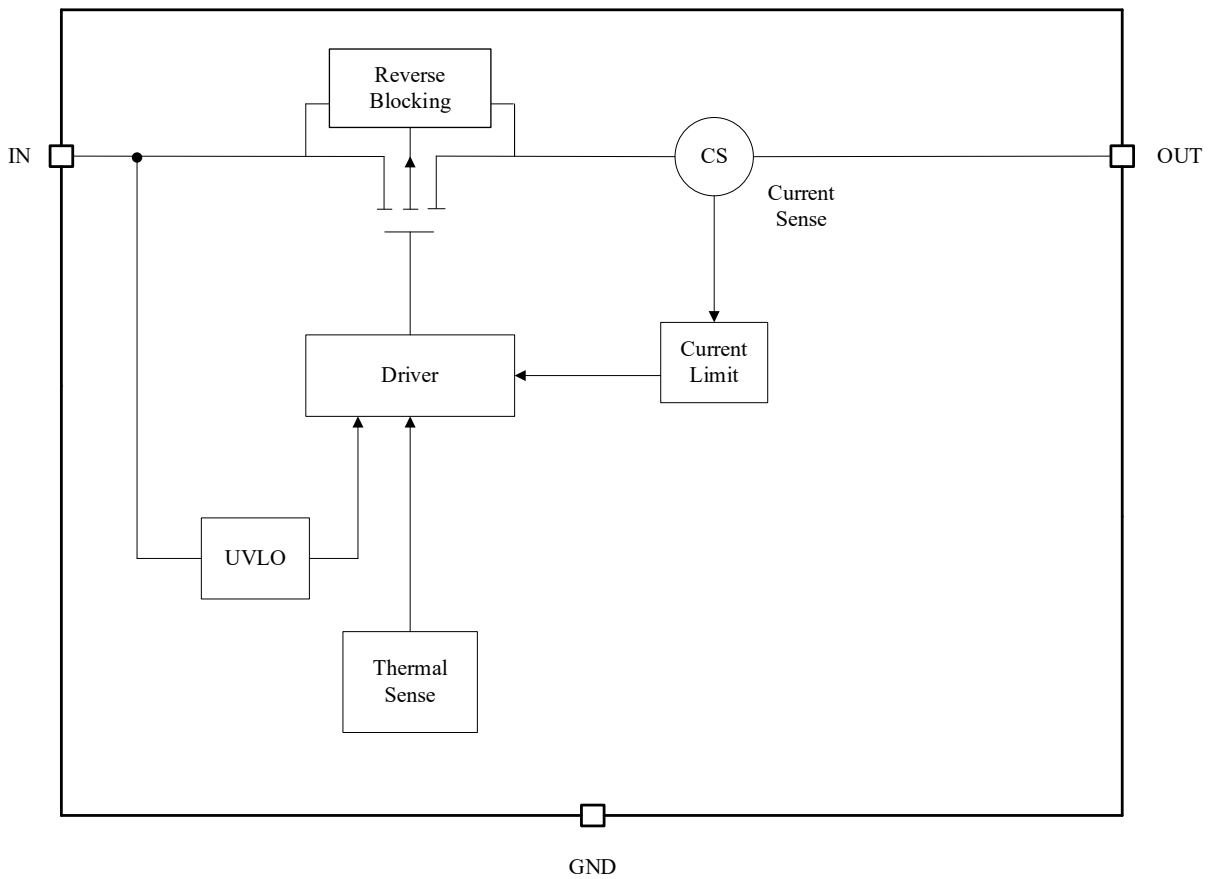

● **11.3 Feature Description**

● **11.3.1 Current Limiting**

When the switch current reaches the maximum limit, the WP25142T3-B operates in a constant-current mode to prohibit excessive currents from causing damage.

● **11.3.2 Thermal Shutdown**

Thermal shutdown protects the device from internally or externally generated excessive temperatures. During an overtemperature condition the switch is turned off. The switch automatically turns on again if the temperature of the die drops below the threshold temperature.

● 11.4 Device Functional Modes

When the EN pin is actively pulled high and no fault conditions are present, the switch will be turned on, connecting V_{IN} to V_{OUT} . When the EN pin is actively pulled low regardless of the fault condition, the switch will be turned off. In the event that the current limit is exceeded, the device will operate in a constant-current mode until the fault condition is removed. During thermal shutdown conditions, the switch will automatically turn off and will turn back on again if the temperature of the die drops below the threshold temperature.

● 12 Application and Implementation

● 12.1 Application Information

● 12.1.1 Input Capacitor

To limit the voltage drop on the input supply caused by transient inrush current, a capacitor 1 μ F or larger must be placed between the IN and GND pins.

● 12.1.2 Output Capacitor

A 1 μ F or larger capacitor should be placed between the OUT and GND pins. This capacitor will prevent parasitic board inductances from forcing OUT below GND when the switch turns off.

● 12.1.3 Undervoltage Lockout

The undervoltage lockout turns off the switch if the input voltage drops below the undervoltage lockout threshold. Under-voltage detection functions only when the switch is enabled.

● 12.1.4 Power Dissipation and Junction Temperature

The junction temperature of the switch depend on several factors such as the load, PCB layout, ambient temperature and package type. Power dissipation can be calculated based on the output current and the $R_{DS(ON)}$ of the switch as below.

$$P_D = R_{DS(ON)} \times I^2$$

The junction temperature can be estimated by the following thermal equation:

$$T_J = P_D \times \theta_{JA} + T_A$$

Where:

T_A = Ambient temperature

θ_{JA} = Thermal resistance

P_D = Total power dissipation

With all possible conditions, the junction temperature must be within the range specified under operating conditions. The maximum output current must be derated at higher ambient temperature to ensure the junction temperature does not exceed the maximum junction temperature which is 125°C.

● 13. Power Supply Recommendations

The device is designed to operate from a V_{IN} range of 2.5 V to 5.5 V. This supply must be well regulated and placed as close to the device terminal as possible with the recommended 1 μ F bypass capacitor. If the supply is located more than a few inches from the device terminals, additional bulk capacitance may be required in

In addition to the ceramic bypass capacitors. If additional bulk capacitance is required, an electrolytic, tantalum, or ceramic capacitor of 10 μF may be sufficient

● 14. Layout

For best performance, all traces should be as short as possible, the input and output capacitors should be placed close to the device to minimize the effects that parasitic trace inductances may have on normal and short-circuit operation. The V_{IN} terminal should be bypassed to ground with low ESR ceramic bypass capacitors. The typical recommended bypass capacitance is 1 μF ceramic with X5R or X7R dielectric. This capacitor should be placed as close to the device terminals as possible. Using wide traces for V_{IN} , V_{OUT} , and GND will help minimize parasitic electrical effects along with minimizing the case to ambient thermal impedance.

● 14.1 Layout Example

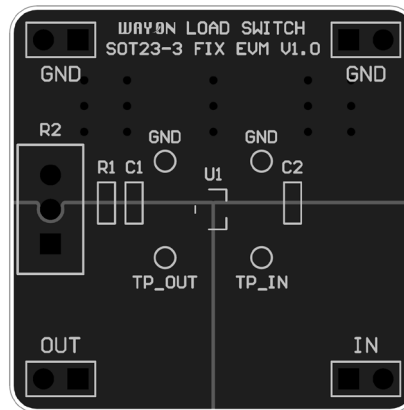

● 15 Evaluation Modules

Evaluation Modules (EVMs) are available to help evaluate the device performance. We have evaluation modules for different packages, you can contact us by phone or address at the end to get the evaluation module or schematic.

The module names are listed in the table below.

NAME	PACKAGE	EVALUATION MODULE
WP25142T3-B	SOT23-3	WAYON LOAD SWITCH SOT23-3 FIX EVM V1.0

● 16 Naming Conventions

WP AB CCC D EE - F

WP: WAYON Protection IC;

A: Product Category –2: Load Switch;

B: Maximum Output Voltage – 5: <6V;

CCC: Maximum Output Current –14: 1.4A;

D: Serial number;

EE: Package – T3: SOT23-3;

F: Current Limit Accuracy – B: 20%;

● 17 Package Information

SOT 23-3

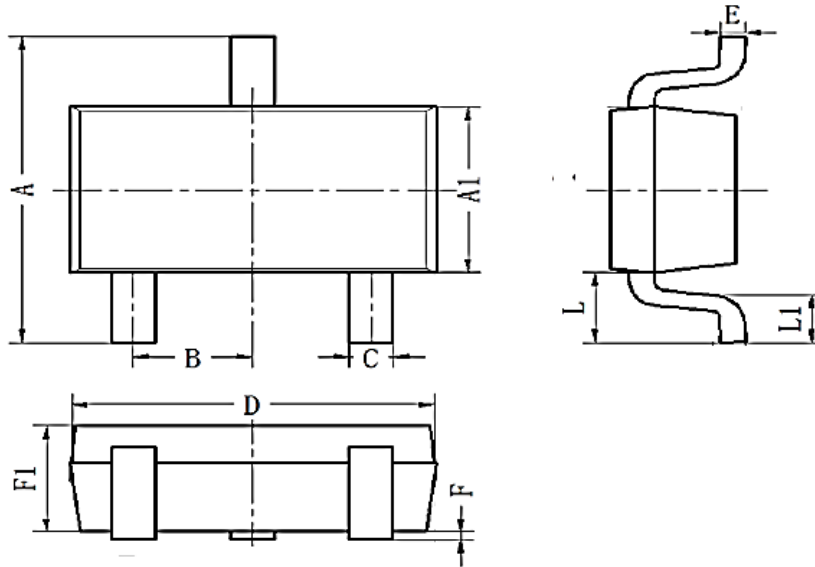

SYMBOL	DIMENSIONS IN MILLIMETERS		
	MIN	NOM	MAX
A	2.60	2.80	3.00
A1	1.50	1.60	1.70
B	0.95(BSC)		
C	0.25	0.40	0.50
D	2.82	2.92	3.02
E	0.10	0.15	0.20
L	0.59REF		
L1	0.30	0.45	0.60
F1	0.90	1.10	1.30
F	0.00	0.08	0.15

● 18 Ordering Information

PART NUMBER	CURRENT LIMIT	PACKAGE	PACKING QUANTITY	MARKING*
WP25142T3-B	2A	SOT23-3	3k/Reel	WP25142B XXXX

Contact Information

No.1001, Shiwan(7) Road, Pudong District, Shanghai, P.R.China.201202

Tel: 86-21-68960674 Fax: 86-21-50757680 Email: market@way-on.com

WAYON website: <http://www.way-on.com>

For additional information, please contact your local Sales Representative.

WAYON® is registered trademark of Wayon Corporation.

Specifications are subject to change without notice.

The device characteristics and parameters in this data sheet can and do vary in different applications and actual device performance may vary over time.

Users should verify actual device performance in their specific applications.

单击下面可查看定价，库存，交付和生命周期等信息

[>>WAY-ON\(维安\)](#)