

Low Loss Current Limited Load Switch

General Description

The WP250651T5-B is current limited P-channel MOSFET power switch designed for high-side load switching applications. This switch operates with inputs ranging from 2.5V to 5.5V, making it ideal for both 3.3V and 5V systems. An integrated current-limiting circuit protects the input supply against large currents which may cause the supply to fall out of regulation. The WP250651T5-B is also protected from thermal overload which limits power dissipation and junction temperatures. It can be used to control load that requires 0.65A. The quiescent supply current in active mode is only 28 μ A. In shutdown mode, the supply current decreases to less than 1 μ A. Fault flag ($\overline{\text{FLT}}$) can indicate over current and fault conditions.

The WP250651T5-B is available in Pb-free packages and is specified over the -40°C to +85°C ambient temperature range.

Features

- Input Voltage Range: 2.5V to 5.5V
- 1A Accurate Current Limit
- Reverse Current Blocking
- Short-Circuit Response: 2 μ s
- Very Low Quiescent Current: 28 μ A (Typ)

- 1 μ A Max Shutdown Supply Current
- Fault Flag ($\overline{\text{FLT}}$) output for over current and fault conditions
- Built-in Pull-up Resistor for EN Pin
- Automatic Output Discharge at Shutdown
- Under-Voltage Lockout
- Thermal Shutdown
- 2kV ESD Rating
- Package: SOT23-5
- Ambient Temperature Range: -40°C to +85°C

Applications

- Laptop/Desktop Computers and Netbooks
- 3G Wireless Cards
- Smart Phones and PDAs
- LCD TVs and Monitors
- Set-Top-Boxes
- MP3/MP4
- Printers
- Portable Game Players
- Portable Media Players and MIDs
- USB Keyboards
- USB Hard Disk Drives
- USB Memory Drives
- USB Hubs

Typical Application

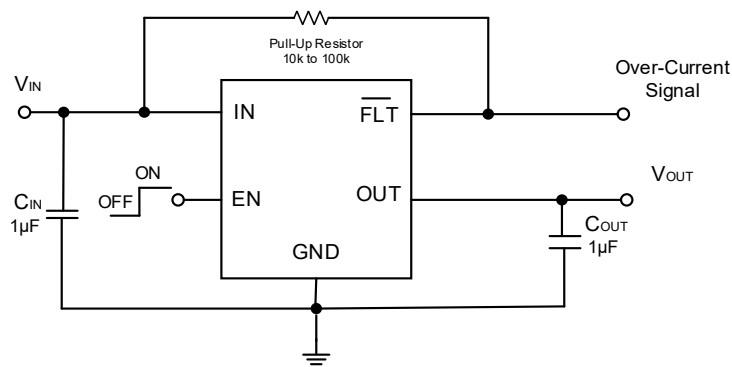

Note: Tantalum or Aluminum Electrolytic capacitors (C_{IN} and C_{OUT}) may be required for USB applications

Pin Configuration

(Top View)

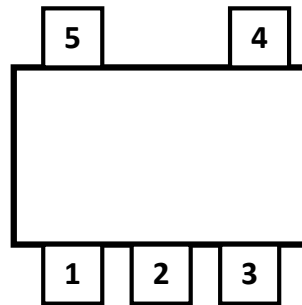

Pin Description

Pin Number	Pin Name	Pin Function
1	OUT	Power output.
2	GND	Ground pin.
3	$\overline{\text{FLT}}$	Open drain fault flag
4	EN	Enable input, High enable.
5	IN	Power supply input.

Absolute Maximum Ratings

Parameter	Rating	Unit
IN, EN, $\overline{\text{FLT}}$ Voltage	-0.3 to 6	V
OUT Voltage	-0.3 to $V_{\text{IN}} + 0.3$	V
OUT Current	Internal Limited	A
Power Dissipation	400	mW
Package Thermal Resistance (θ_{JA})	250	$^{\circ}\text{C}/\text{W}$
Operating Junction Temperature	-40 to 125	$^{\circ}\text{C}$
Storage Temperature	-55 to 150	$^{\circ}\text{C}$
Lead Temperature (Soldering, 10 sec)	300	$^{\circ}\text{C}$

Electrical Characteristics ($V_{IN}=+5.0V$, $T_A=25^{\circ}C$, unless otherwise specified.)

Symbol	Parameter	Test Conditions	Min	Typ.	Max	Unit
V_{IN}	Input Voltage Range		2.5		5.5	V
I_{SHDN}	Shutdown Quiescent Current	Disabled, OUT floating or shorted to ground		0.3	1	μA
I_Q	Quiescent Current	Enabled, $I_{OUT}=0$		28	60	μA
$R_{DS(ON)}$	Switch on-resistance	$V_{IN}=5V$, $I_{OUT}=0.6A$		70	120	m Ω
I_{LMT}	Current Limit	$V_{IN}=5V$, $V_{OUT}=4.5V$	0.75	1	1.25	A
	Current Limit (short circuit)	$V_{IN}=5V$, $V_{OUT}=0V$	0.8	1.2	1.5	A
V_{IL}	EN Input Logic Low Voltage	Note 1			0.5	V
V_{IH}	EN Input Logic High Voltage	Note 1	1.5			V
R_{FLT}	\overline{FLT} Low Resistance	Note 2		250		Ω
T_{FLT_Delay}	\overline{FLT} Delay Time	Note 2		15		ms
I_{SINK}	EN Input leakage	$V_{EN}=5V$		0.01	1	μA
		$V_{EN}=0V$	-2	-0.25		μA
V_{UVLO}	Input UVLO Threshold		1.4	1.8	2.2	V
$V_{UVLOHys}$	Input UVLO Hysteresis			0.1		V
I_{REV}	Reverse Leakage Current	$V_{IN}=0V$, $V_{OUT}=5V$, I_{REV} at V_{IN}		0.1	1	μA
T_{ON}	Output Turn-on Delay Time	$V_{IN}=5V$, $C_L=1\mu F$, $R_{LOAD}=100\Omega$	0.2	0.5	1	ms
T_R	Output Turn-on Rise Time	$V_{IN}=5V$, $C_L=1\mu F$, $R_{LOAD}=100\Omega$	0.2	0.4	0.8	ms
T_{OFF}	Output Turn-off Delay Time	$V_{IN}=5V$, $C_L=1\mu F$, $R_{LOAD}=100\Omega$	0.2	0.5	0.8	ms
T_F	Output Turn-off Fall Time	$V_{IN}=5V$, $C_L=1\mu F$, $R_{LOAD}=100\Omega$	100	350	500	μs
$R_{dischrg}$	Output discharge FET $R_{DS(ON)}$	Disabled, $V_{IN}=5V$, $V_{OUT}=1V$	50	120	300	Ω
T_{SHDN}	Thermal shutdown threshold	$V_{IN}=5V$		150		$^{\circ}C$
T_{HYS}	Thermal shutdown hysteresis	$V_{IN}=5V$		20		$^{\circ}C$
ESD HBM	Human Body Model ESD Protection			2000		V

Note 1: When EN pin is floating, the chip is enabled.

Note 2: Guaranteed by design.

WP250651T5-B

Typical Performance Characteristics

($T_A=25^{\circ}\text{C}$, unless otherwise noted)

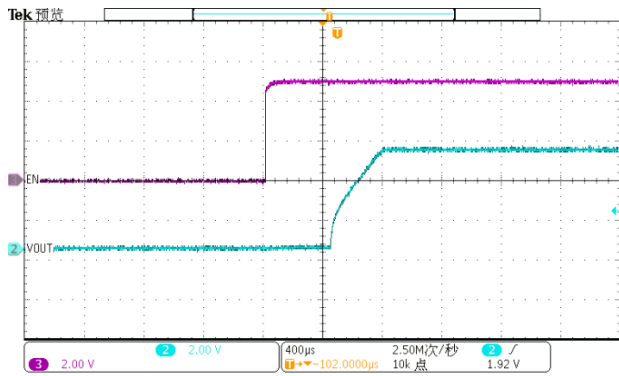

Turn On Response

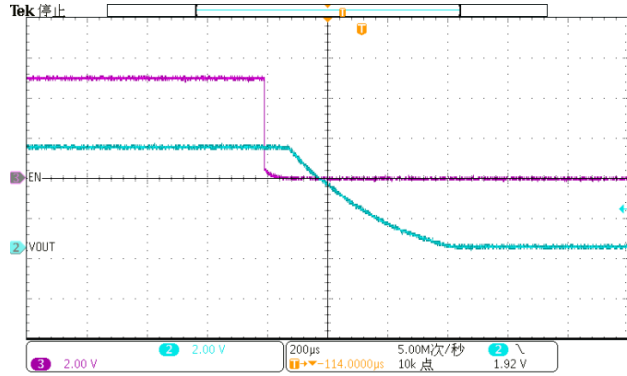

Turn Off Response

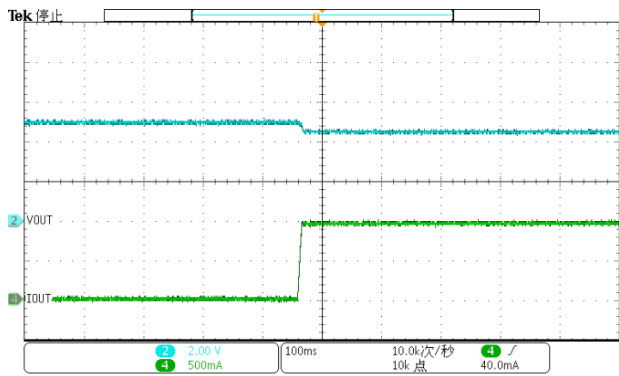

Overload Current-limit

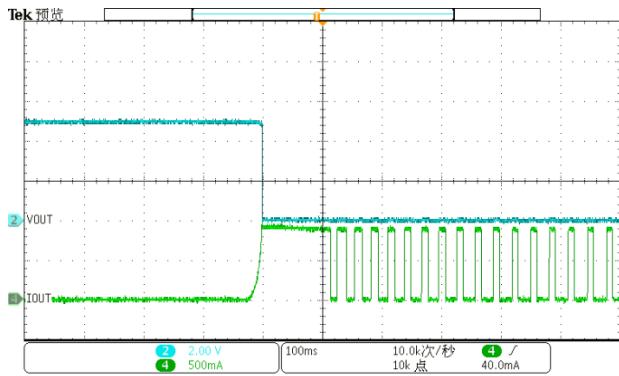

Short Current Response & Thermal Shutdown

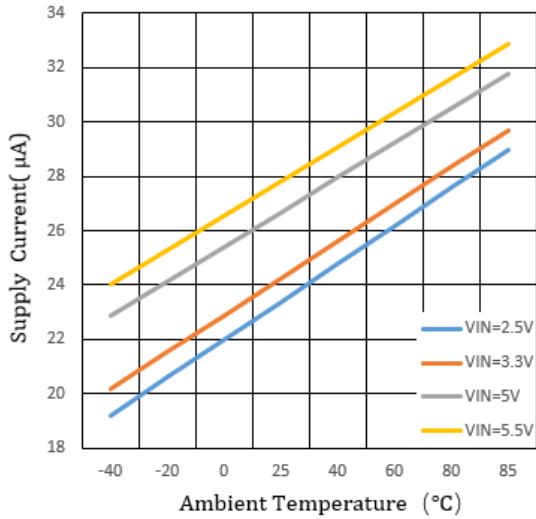

Quiescent Supply Current vs. Ambient Temperature

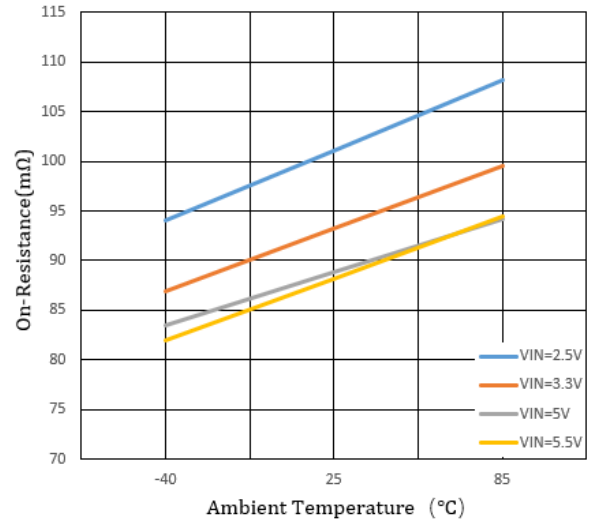

Switch On-Resistance vs. Ambient Temperature

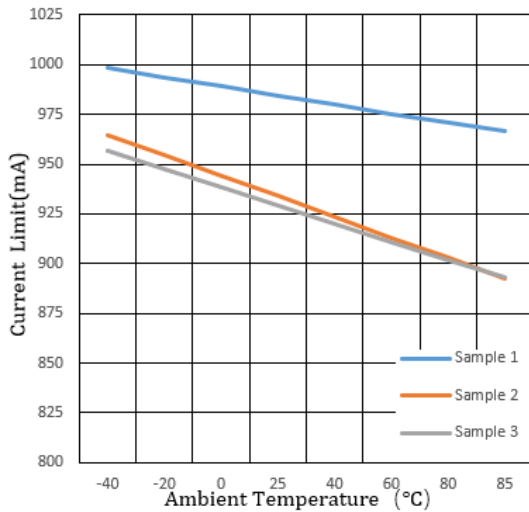

Current-Limit Threshold vs. Ambient Temperature

Block Diagram

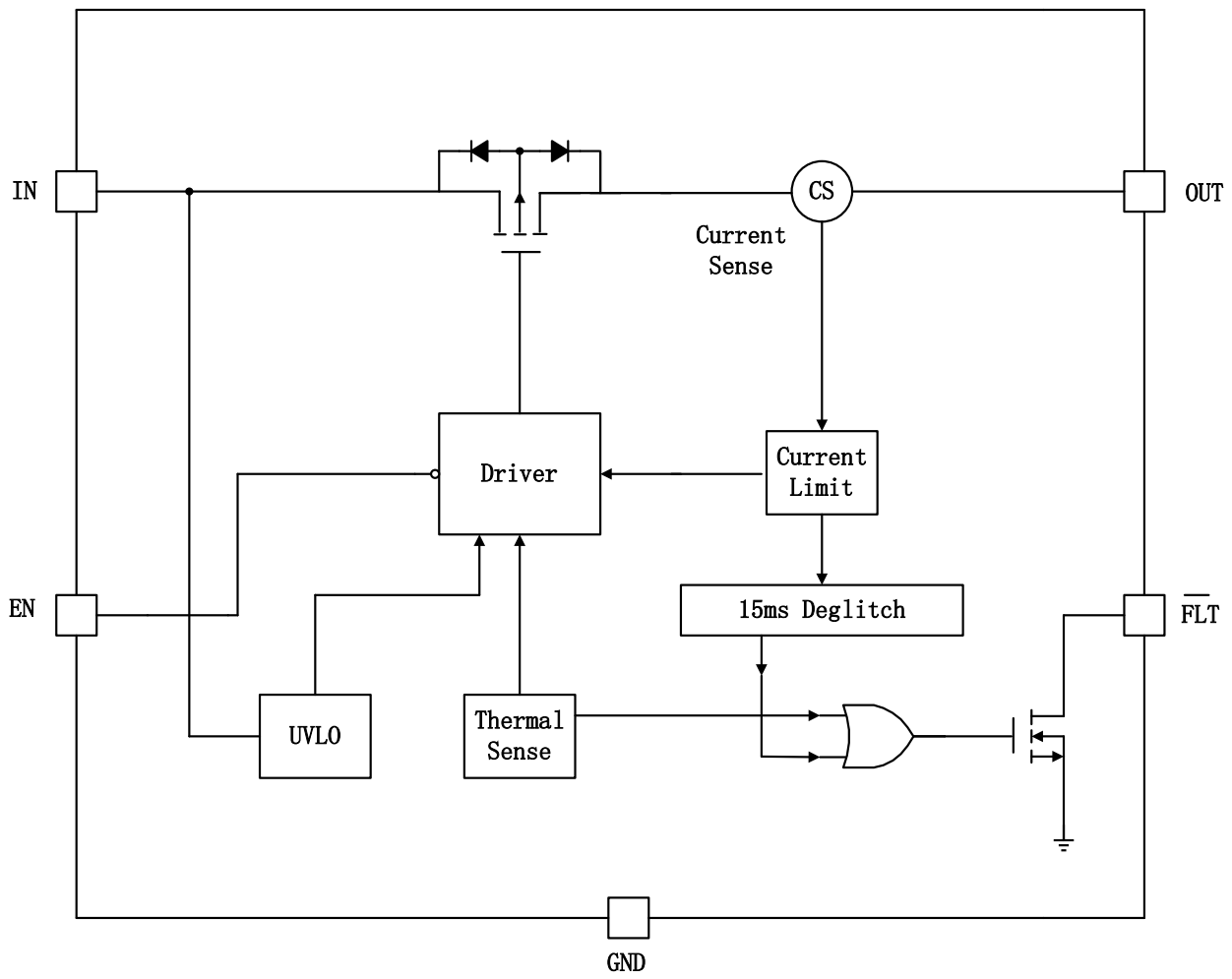

Operation

WP250651T5-B is an integrated power switch with a low $R_{DS(ON)}$ P-channel MOSFET, internal gate drive circuit. When the WP250651T5-B turns on, it can deliver up to 0.65A continuous current to load. When the device is active, if there is no load, the device only consumes 28 μ A supply current, which makes the device suitable for battery powered applications.

Power Supply Considerations

A 0.1 μ F to 1 μ F ceramic bypass capacitor between IN and GND, close to the device, is recommended. Placing a high-value electrolytic capacitor on the output pin is recommended when the output load is heavy. This precaution reduces power-supply transients that may cause ringing on the input and minimize the input voltage droops. Additionally, bypassing the output with a 0.1 μ F to 1 μ F ceramic capacitor improves the immunity of the device to short-circuit transients.

Power Dissipation and Junction Temperature

The low on-resistance on the P-channel MOSFET allows the small surface-mount packages to pass large currents. It is good design practice to check power dissipation and junction temperature for each application. Begin by determining the $R_{DS(ON)}$ of the P-channel MOSFET relative to the input voltage and operating temperature. Using the highest operating ambient temperature of interest and $R_{DS(ON)}$, the power dissipation per switch can be calculated by:

$$P_D = R_{DS(ON)} \times I^2$$

Finally, calculate the junction temperature:

$$T_J = P_D \times R_{\theta JA} + T_A$$

Where:

T_A = Ambient temperature

$R_{\theta JA}$ = Thermal resistance

P_D = Total power dissipation

Compare the calculated junction temperature with the maximum junction temperature which is 125°C. If they are within degrees, either the maximum load current needs to be reduced or another package option will be required.

Over Current

A sense FET is employed to check for over current conditions. When an over current condition is detected, the device maintains a constant output current and reduces the output voltage accordingly. WP250651T5-B will limit the current until the overload condition is removed or the device begins to thermal cycle.

Three possible overload conditions can occur. In the first condition, the output has been shorted before the device is enabled or before V_{IN} has been applied. The WP250651T5-B senses the short and immediately switches into a constant-current output.

In the second condition, a short or an overload occurs while the device is enabled. At the instant the overload occurs, high currents may flow for a short period of time before the current-limit circuit can react. After the current-limit circuit reached the over current trip threshold, the device switches into constant-current mode.

In the third condition, the load has been gradually increased beyond the recommended operating current. The current is permitted to rise until the current-limit threshold is reached or until the thermal limit of the device is exceeded. The WP250651T5-B is capable of delivering current up to the current-limit threshold without damaging the device. Once the threshold has been reached, the device switches into its constant-current mode.

Thermal Protection

Thermal protection prevents damage to the IC when heavy-overload or short-circuit faults are present for extended periods of time. The WP250651T5-B implements a thermal sensing to monitor the operating junction temperature of the power distribution switch. In an over current or short-circuit condition, the junction temperature rises due to excessive power dissipation. Once the die temperature rises to approximately 150°C due to over current conditions, the internal thermal sense circuitry turns the power switch off, thus preventing the power switch from damage. Hysteresis is built into the thermal sense circuit, and after the device has

WP250651T5-B

cooled approximately 20° C, the switch turns back on. The switch continues to cycle in this manner until the load fault or input power is removed.

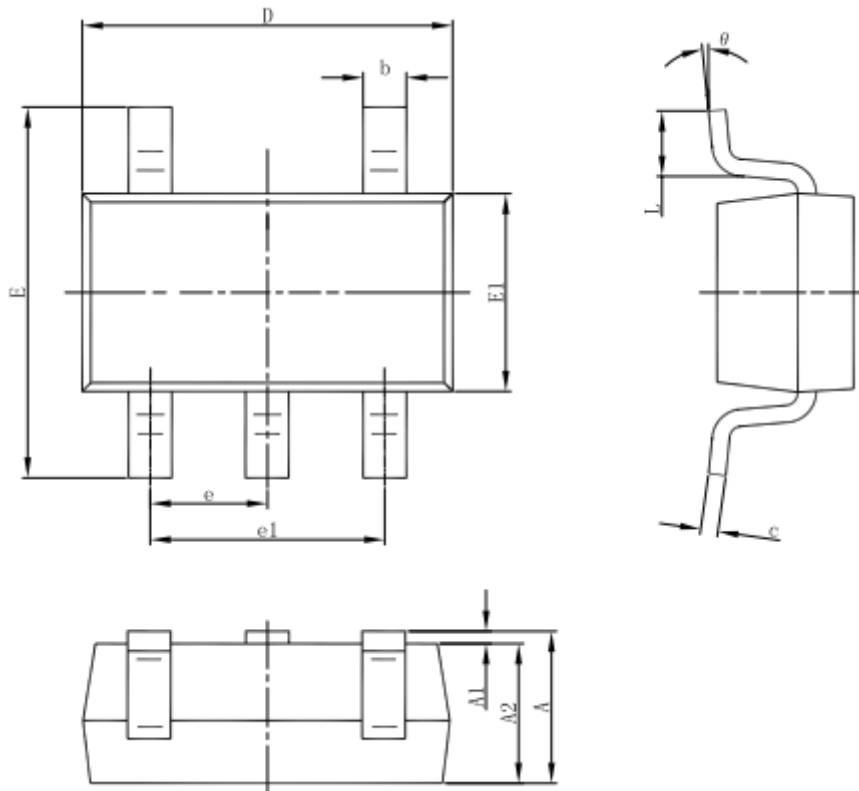
Package Information

SOT23-5

SYMBOL	DIMENSIONS IN MILLIMETERS	
	MIN	MAX
A	1.000	1.350
A1	0.000	0.150
A2	1.000	1.200
b	0.300	0.500
c	0.100	0.200
D	2.820	3.020
E1	1.500	1.700
E	2.600	3.000
e	0.950(BSC)	
e1	1.800	2.000
L	0.300	0.600
θ	0°	8°

WP250651T5-B

Ordering Information

Part Number	Current Limit	Package	Packing Quantity	Marking*
WP250651T5-B	1A	SOT23-5	3k/Reel	50651 BXXXX

*XXXX is variable.

Contact Information

No.1001, Shiwan(7) Road, Pudong District, Shanghai, P.R.China.201202

Tel: 86-21-68960674 Fax: 86-21-50757680 Email: market@way-on.com

WAYON website: <http://www.way-on.com>

For additional information, please contact your local Sales Representative.

 is registered trademark of Wayon Corporation.

Specifications are subject to change without notice.

The device characteristics and parameters in this data sheet can and do vary in different applications and actual device performance may vary over time.

Users should verify actual device performance in their specific applications.

单击下面可查看定价，库存，交付和生命周期等信息

[>>WAY-ON\(维安\)](#)