

PNP Silicon Transistor

Features

- Epitaxial Planar Die Construction
- Complementary NPN Type Available (WT3904)

Mechanical Characteristics

- SOT-23 Package
- Marking : Making Code
- RoHS Compliant

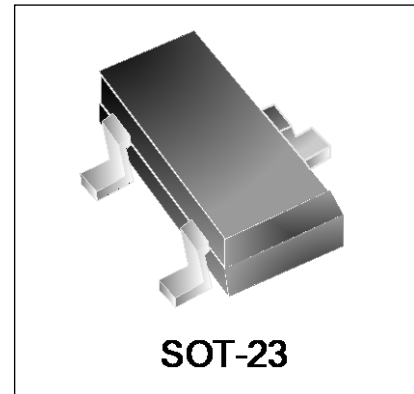

Schematic & PIN Configuration

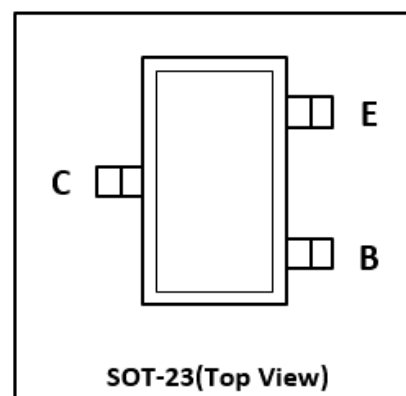
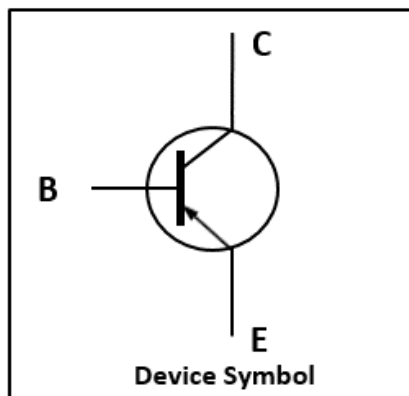

Absolute Maximum Rating

Parameter	Symbol	Value	Unit
Collector Base Voltage	V_{CBO}	-40	V
Collector Emitter Voltage	V_{CEO}	-40	V
Emitter Base Voltage	V_{EBO}	-5	V
Collector Current	I_C	-200	mA
Collector Power Dissipation	P_C	200	mW
Junction Temperature	T_j	150	°C
Storage Temperature	T_{stg}	-55 ~ 150	°C
Thermal Resistance, Junction to Ambient	$R_{\theta JA}$	625	°C/W

Electrical Characteristics (T_{amb}=25°C unless otherwise specified)

Parameter	Symbol	Test Conditions	Min.	Typ.	Max.	Unit
Collector-base breakdown voltage	V _{(BR)CBO}	I _C = -10μA, I _E = 0	-40	-	-	V
Collector-emitter breakdown voltage	V _{(BR)CEO}	I _C = -1mA, I _B = 0	-40	-	-	V
Emitter-base breakdown voltage	V _{(BR)EBO}	I _E = -10μA, I _C = 0	-5	-	-	V
Collector cut-off current	I _{CBO}	V _{CB} = -40V, I _E = 0	-	-	-100	nA
Collector cut-off current	I _{CEX}	V _{CE} = -30V, V _{BE(off)} = 3V	-	-	-50	nA
Emitter cut-off current	I _{EBO}	V _{EB} = -5V, I _C = 0	-	-	-100	nA
DC current gain	h _{FE(1)}	V _{CE} = -5V, I _C = -1mA	100	-	300	-
	h _{FE(2)}	V _{CE} = -5V, I _C = -10mA	100	-	-	-
Collector-emitter saturation voltage	V _{CE(sat)}	I _C = -50mA, I _B = -5mA	-	-	-0.3	V
Base-emitter saturation voltage	V _{BE(sat)}	I _C = -50mA, I _B = -5mA	-	-	-0.95	V
Transition frequency	f _T	V _{CE} =-20V, I _C =-10mA, f=100MHz	300	-	-	MHz
Delay time	t _d	V _{CC} = -3V, V _{BC} = -0.5V, I _C = -10mA, I _{B1} = I _{B2} = -1mA	-	-	35	ns
Rise time	t _r		-	-	35	ns
Storage time	t _s	V _{CC} = -3V, I _C = -10mA, I _{B1} = -I _{B2} = -1mA	-	-	225	ns
Fall time	t _f		-	-	75	ns

Typical Characteristics

Figure 1. Static Characteristic

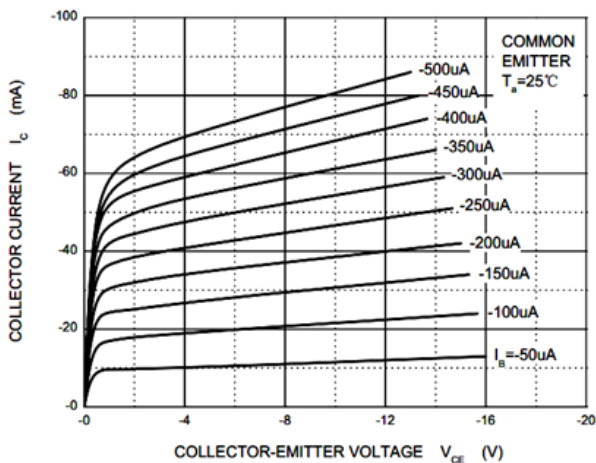

Figure 2. h_{FE} vs. I_c

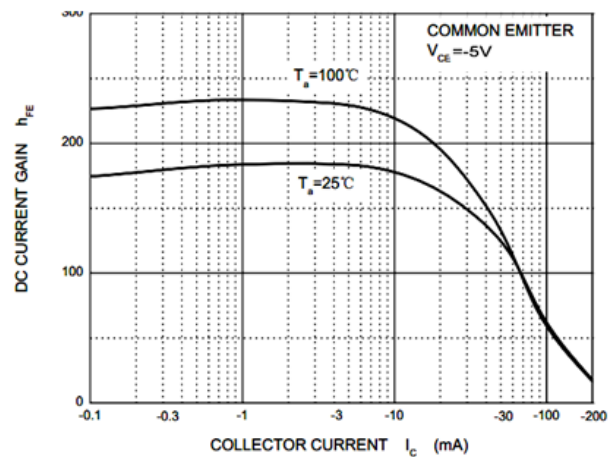

Figure 3. $V_{CE(sat)}$ vs. I_c

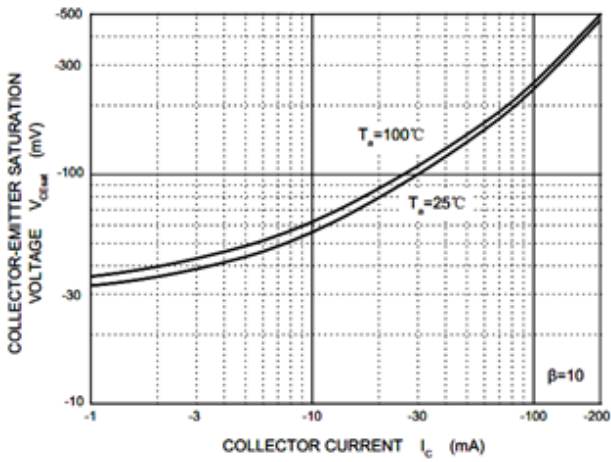

Figure 4. $V_{BE(sat)}$ vs. I_c

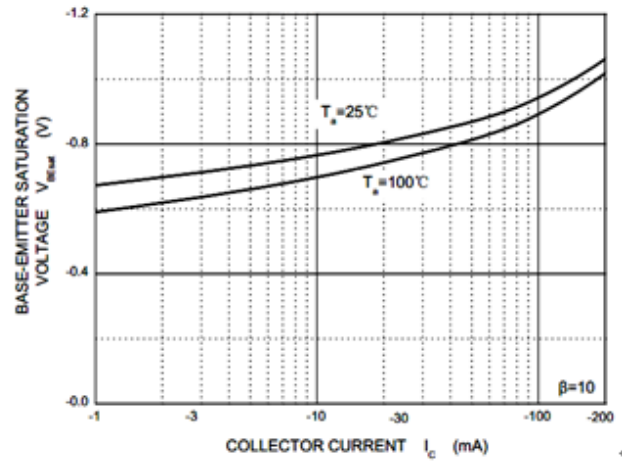

Figure 5. I_c vs. V_{BE}

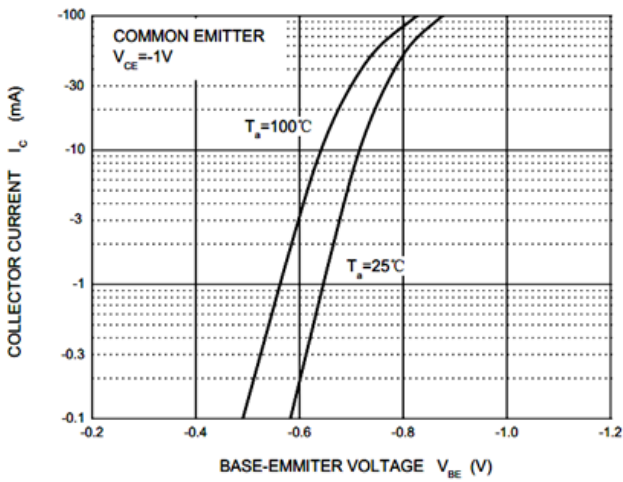

Figure 6. C_{ob} / C_{ib} vs. V_{CB} / V_{EB}

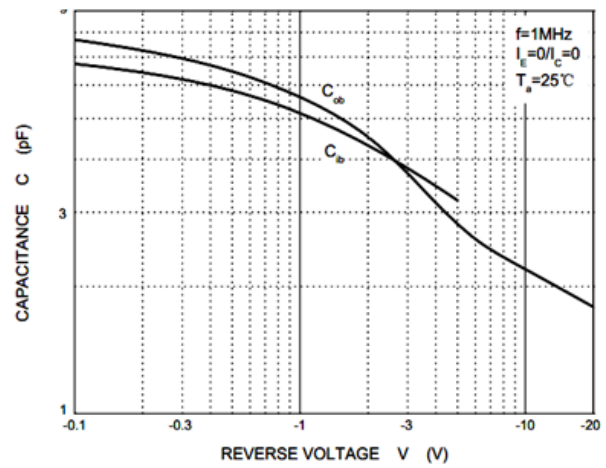

Figure 7. f_T vs. I_c

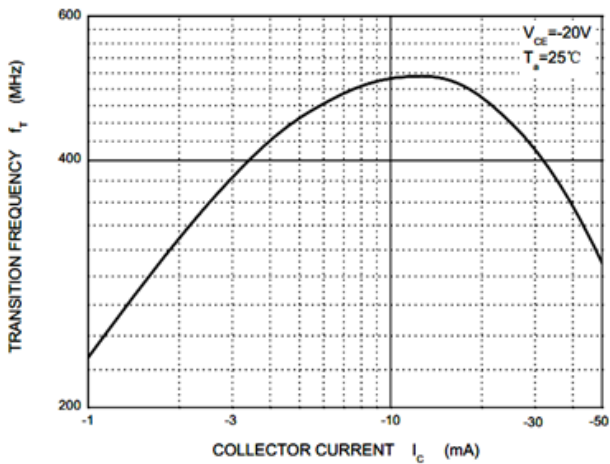
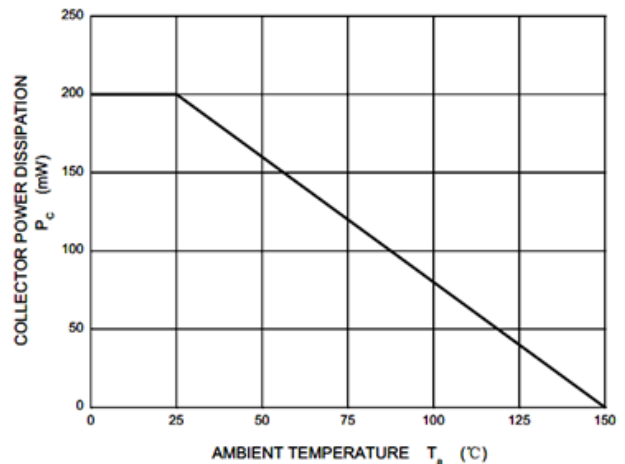

Figure 8. P_c vs. T_a



Outline Drawing – SOT-23

PACKAGE OUTLINE

SOT-23

SYMBOL	MILLIMETER		INCHES	
	MIN	MAX	MIN	MAX
A	0.90	1.15	0.035	0.045
A1	0.00	0.10	0.000	0.004
A2	0.60	0.70	0.0236	0.0275
b	0.30	0.50	0.012	0.020
c	0.08	0.15	0.003	0.006
D	2.80	3.00	0.110	0.118
E	2.25	2.55	0.089	0.100
E1	1.20	1.40	0.047	0.055
e	0.95 BSC		0.0374 BSC	
e1	1.80	2.00	0.071	0.079
L	0.30	0.50	0.012	0.020
θ	0	8°	0	8°

DIMENSIONS		
DIM	INCHES	MILLIMETERS
M	0.0795	2.02
C	0.0315	0.80
Z	0.111	2.82
e	0.037 BSC	0.95 BSC
e1	0.075 BSC	1.9 BSC
b	0.0315	0.80

Notes

1. Dimensioning and tolerances per ANSI Y14.5M, 1985.
2. Controlling Dimension: Inches
3. Pin 3 is the cathode (Unidirectional Only).
4. Dimensions are exclusive of mold flash and metal burrs.

Marking Codes

Part Number	WT3906
Marking Code	

Package Information

Qty: 3k/Reel

CONTACT INFORMATION

No.1001, Shiwan (7) Road, Pudong District, Shanghai, P.R.China.201207
 Tel: 86-21-68969993 Fax: 86-21-50757680 Email: market@way-on.com
 WAYON website: <http://www.way-on.com>
 For additional information, please contact your local Sales Representative.

WAYON® is registered trademark of Wayon Corporation.

*Specifications are subject to change without notice.
 The device characteristics and parameters in this data sheet can and do vary in different applications and actual device performance may vary over time.
 Users should verify actual device performance in their specific applications.*

单击下面可查看定价，库存，交付和生命周期等信息

[>>WAY-ON\(维安\)](#)