

### Features

- 2-electrode arrester
- Very small size
- Extremely fast response time
- Stable performance over life
- Extremely low capacitance (<1pF)
- High insulation resistance

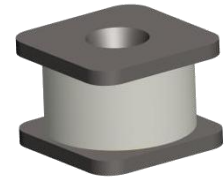

### Application

- Modem
- Splitter
- Base stations
- PCI cards
- Application with limited space

### Electrical specifications

Part number	DC Spark-over Voltage <sup>1) 2)</sup>	Maximum Impulse Spark-over Voltage	Service Life <sup>3)</sup>	Insulation resistance	Capacitance	Marking Code
		1KV/ $\mu$ s	8/20 $\mu$ s 10times	@ 100V <sub>DC</sub>	@ 1 MHz	
	(V)	(V)	(KA)	(G $\Omega$ )	(pF)	
GDTN2RS6-1000	1000 $\pm$ 20%	1900	3KA	> 1	< 1	None

1) At delivery AQL 0.65 level II, DIN ISO 2859.

2) In ionized mode.

3) Tests according to ITU-T Rec. K. 12 and UL 497B.

Terms and current waveforms in accordance with: ITU-T Rec. K.12; IEC 61643-21 and DIN 57845/VDE0845.

### Thermal Resistances

Symbol	Parameter	Value	Unit
Ts & Tj	Storage & Operating temperature range	-40 to +85	°C

**Soldering Parameters**

Reflow Condition		
Pre Heat	Temperature Min ( $T_{s(min)}$ )	150°C
	Temperature Max ( $T_{s(max)}$ )	200°C
	Time (min to max) ( $t_s$ )	60-190 s
Average ramp up rate (Liquidus Temp) ( $T_L$ ) to peak		3°C/s max
Ts(max) to $T_L$ - Ramp-up Rate		3°C/s max
Reflow	Temperature ( $T_L$ ) (Liquidus)	217°C
	Temperature ( $t_L$ )	60-150 s
Peak Temperature ( $T_P$ )		260 <sup>+0/-5</sup> °C
Time within actual peak Temperature ( $t_p$ )		20-40 s
Ramp-down Rate		5°C/s max
Time 25°C to peak Temperature ( $T_P$ )		8 minutes Max.
Do not exceed		260°C

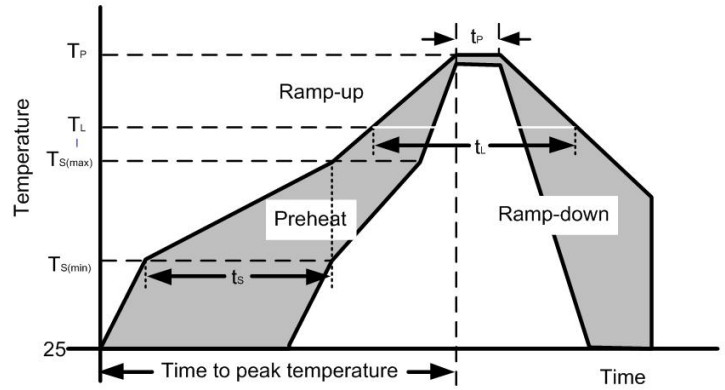

**Dimensional drawing**

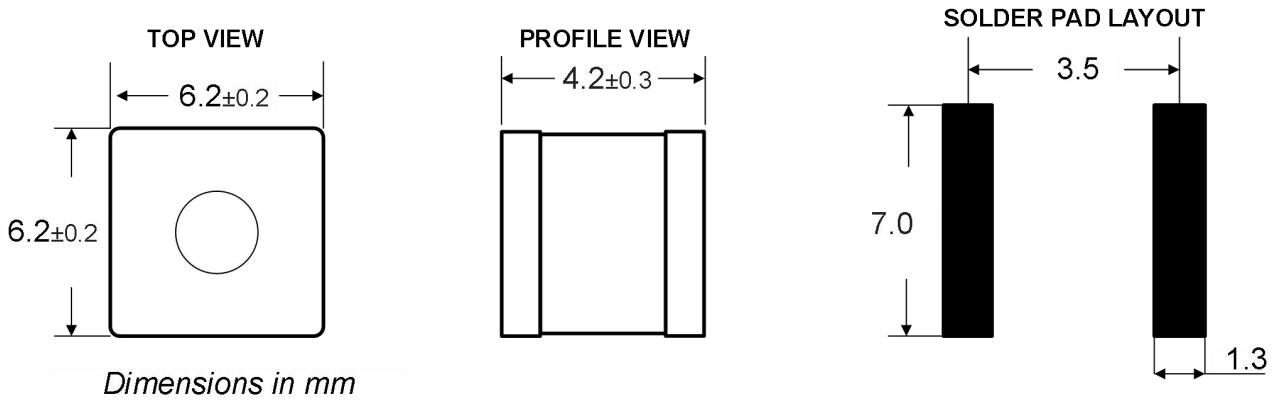

**Cautions and warnings**

- Surge arresters must not be operated directly in power supply networks.
- Surge arresters may become hot in case of longer periods of current stress (danger of burning).
- Surge arresters may be used only within their specified values. In case of overload, the headcontacts may fail or the component may be destroyed.
- Damaged surge arresters must not be re-used.

## Part Numbering System

**GDT N 2R S6 - 1000**

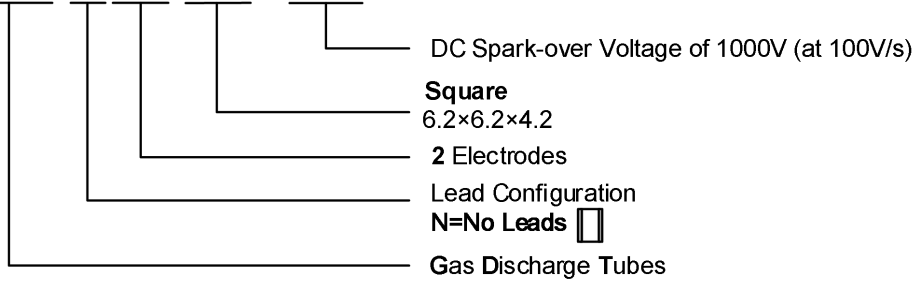

## Package Information

Tape and Reel: 800 Pcs/Reel .

## Contact Information

No.1001, Shiwan(7) Road, Pudong District, Shanghai, P.R.China.201207

Tel: 86-21-68969993 Fax: 86-21-50757680 Email: market@way-on.com

WAYON website: <http://www.way-on.com>

For additional information, please contact your local Sales Representative.

**WAYON** ® are registered trademarks of Wayon Corporation.

*Specifications are subject to change without notice.  
The device characteristics and parameters in this data sheet can and do vary in different applications and actual device performance may vary over time.  
Users should verify actual device performance in their specific applications.*

单击下面可查看定价，库存，交付和生命周期等信息

[>>WAY-ON\(维安\)](#)