



MPC-3120 Series

3.0A, Gate Driver Photo Coupler

Description

The MPC-3120 series Photocoupler is ideally suited for driving power IGBTs and MOSFETs used in motor control inverter applications and inverters in power supply system. It contains an AlGaAs LED optically coupled to an integrated circuit with a power output stage. The 3A peak output current is capable of directly driving most IGBTs with ratings up to 1200 V/100 A. For IGBTs with higher ratings, the MPC-3120 series can be used to drive a discrete power stage which drives the IGBT gate. The Photocoupler operational parameters are guaranteed over the temperature range from -40° C ~ +110°C.

Features

- ±3 A maximum peak output current
- Rail-to-rail output voltage
- Propagation delay time : T_{PHL} = 300 ns (max) , T_{PLH} = 300 ns (max)
- Under Voltage Lock-Out protection (UVLO) with hysteresis
- 35 kV/us minimum Common Mode Rejection (CMR) at V_{CM} = 1500 V
- I_{CC} = 3 mA maximum supply current
- Wide operating range: 15 to 30 Volts (V_{CC})
- Guaranteed performance over temperature -40°C ~ +110°C.

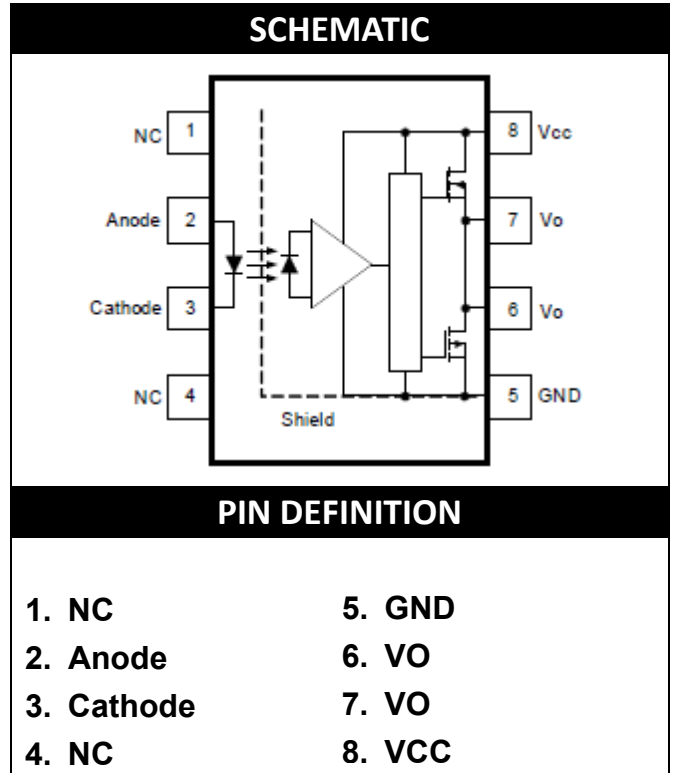

Truth Table

LED	Vo
OFF	Low
ON	High

A 0.1μF bypass capacitor must be connected between Pin 5 and 8.



MPC-3120 Series

3.0A, Gate Driver Photo Coupler

Applications

- Plasma Display Panel
- IGBT/MOSFET gate drive
- Industrial Inverter
- Induction heating
- Uninterruptible power supply (UPS)

ABSOLUTE MAXIMUM RATINGS					
PARAMETER	SYMBOL	MIN.	MAX.	UNIT	Note
Storage Temperature	T _{stg}	-40	+125	°C	-
Operating Temperature	T _{opr}	-40	+110	°C	-
Output IC Junction Temperature	T _J		125	°C	-
Total Output Supply Voltage	(V _{CC} - V _{EE})	0	35	V	-
Average Forward Input Current	I _F		20	mA	-
Reverse Input Voltage	V _R		5	V	-
Peak Transient Input Current	I _{F(TRAN)}		1.0	A	1
“High” Peak Output Current	I _{OH(PEAK)}		3	A	2
“Low” Peak Output Current	I _{OL(PEAK)}		3	A	2
Output Voltage	V _{O(PEAK)}		35	V	-
Power Dissipation	P _I		45	mW	-
Output Power Dissipation	P _O		250	mW	-
Total Power Dissipation	P _T		295	mW	-
Lead Solder Temperature (10s)	T _{sol}		260	°C	-

Note: Ambient temperature = 25°C, unless otherwise specified. Stresses exceeding the absolute maximum ratings can cause permanent damage to the device. Exposure to absolute maximum ratings for long periods of time can adversely affect reliability. Note: Note: A ceramic capacitor (0.1 μF) should be connected between pin 8 and pin 5 to stabilize the operation of a high gain linear amplifier. Otherwise, this Photocoupler may not switch properly. The bypass capacitor should be placed within 1 cm of each pin.

Note 1: Pulse width (PW) ≤ 1 μs, 300 pps

Note 2: Exponential waveform. Pulse width ≤ 0.3 μs, f ≤ 15 kHz



MPC-3120 Series

3.0A, Gate Driver Photo Coupler

ELECTRICAL OPTICAL CHARACTERISTICS							
PARAMETER	SYMBOL	MIN.	TYP.	MAX.	UNIT	TEST CONDITION	NOTE
INPUT CHARACTERISTICS							
Input Forward Voltage	V_F	1.2	1.37	1.8	V	$I_F = 10\text{mA}$	-
Input Reverse Voltage	BV_R	5	-	-	V	$I_R = 10\mu\text{A}$	-
Input Threshold Current (Low to High)	I_{FLH}	-	1.5	5	mA	$V_{CC} = 30\text{V}, V_O > 5\text{V}$	-
Input Threshold Voltage (High to Low)	V_{FHL}	0.8	-	-	V	$V_{CC} = 30\text{V}, V_O < 5\text{V}$	-
Input Capacitance	C_{IN}	-	33	-	pF	$f = 1\text{MHz}, V_F = 0\text{V}$	-
OUTPUT CHARACTERISTICS							
High Level Supply Current	I_{CCH}	-	1.6	3.0	mA	$I_F = 10\text{mA}, V_{CC} = 30\text{V},$ $V_O = \text{Open}$	-
Low Level Supply Current	I_{CCL}	-	2.0	3.0	mA	$I_F = 0\text{mA}, V_{CC} = 30\text{V},$ $V_O = \text{Open}$	-
High level output current	I_{OH}	-	-	-1.0	A	$V_O = (V_{CC} - 1.5\text{V})$	1
		-	-	-3.0		$V_O = (V_{CC} - 4\text{V})$	2
Low level output current	I_{OL}	1.0	-	-	A	$V_O = (V_{EE} + 1.5\text{V})$	1
		3.0	-	-		$V_O = (V_{EE} + 4\text{V})$	2
High level output voltage	V_{OH}	$V_{CC} - 0.3$	$V_{CC} - 0.15$	-	V	$I_F = 10\text{mA}, I_O = -100\text{mA}$	-
Low level output voltage	V_{OL}	-	$V_{EE} + 0.1$	$V_{EE} + 0.25$	V	$I_F = 0\text{mA}, I_O = 100\text{mA}$	-
UVLO Threshold	V_{UVLO+}	11.0	12.4	13.5	V	$V_O > 5\text{V}, I_F = 10\text{mA}$	-
	V_{UVLO-}	9.5	11.1	12.0	V	$V_O < 5\text{V}, I_F = 10\text{mA}$	
UVLO Hysteresis	$UVLO_{HYS}$	-	1.3	-	V	-	-

All Typical values at $T_A = 25^\circ\text{C}$ and $V_{CC} - V_{EE} = 30\text{V}$, unless otherwise specified;

Note 1: Maximum pulse width = 50 μs .

Note 2: Maximum pulse width = 10 μs .



MPC-3120 Series

3.0A, Gate Driver Photo Coupler

SWITCHING SPECIFICATION							
PARAMETER	SYMBOL	MIN.	TYP.	MAX.	UNIT	TEST CONDITION	NOTE
Propagation Delay Time to High Output Level	tPLH	50	135	300	ns	Rg = 10Ω, Cg = 25nF, f = 10 kHz, Duty Cycle = 50% IF = 7 to 16 mA, VCC = 10 to 30V VEE = ground	
Propagation Delay Time to Low Output Level	tPHL	50	140	300	ns		
Pulse Width Distortion	PWD		5	100	ns		
Propagation delay difference between any two parts or channels	PDD	-100		100	ns		1
Output Rise Time (10 to 90%)	tr		35		ns		
Output Fall Time (90 to 10%)	tf		35		ns		
Common mode transient immunity at high level output	CM _H	35			KV/us	TA = 25°C, IF = 10 to 16 mA, VCM = 1500 V, VCC = 30 V	2
Common mode transient immunity at low level output	CM _L	35			KV/us	TA = 25°C, VF = 0 V, VCM = 1500 V, VCC = 30 V	3

All Typical values at TA = 25°C and VCC – VEE = 30 V, unless otherwise specified;

Note 1: The difference between tPHL and tPLH between any two parts under same test conditions.

Note 2: CMH is the maximum rate of rise of the common mode voltage that can be sustained with the output voltage in the logic high state (VO > 15 V).

Note 3: CML is the maximum rate of fall of the common mode voltage that can be sustained with the output voltage in the logic low state (VO < 1 V).



MPC-3120 Series

3.0A, Gate Driver Photo Coupler

TYPICAL PERFORMANCE CURVES & TEST CIRCUITS

Fig.1 High output rail voltage vs. Temperature

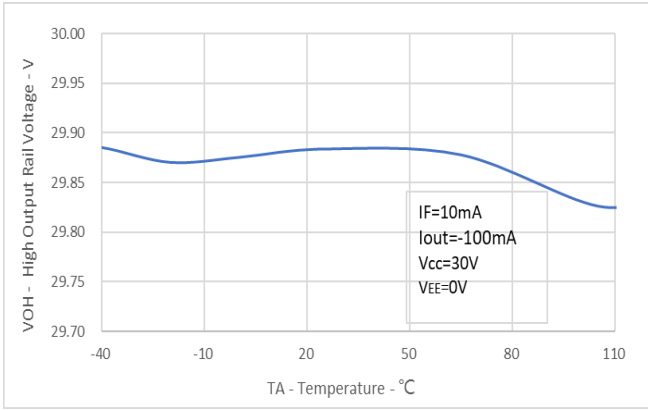

Fig.2 V_{OH} vs. Temperature

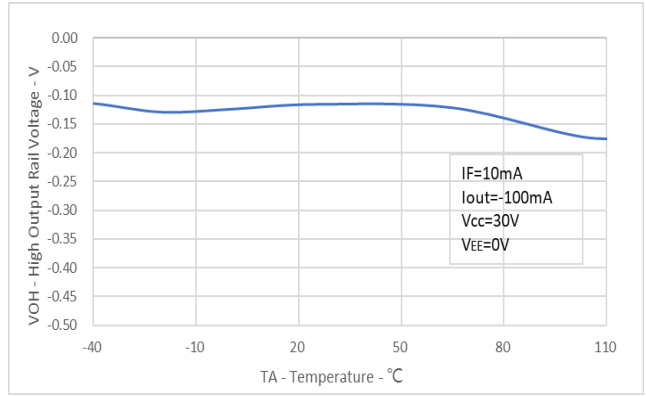

Fig.3 V_{OL} vs. Temperature

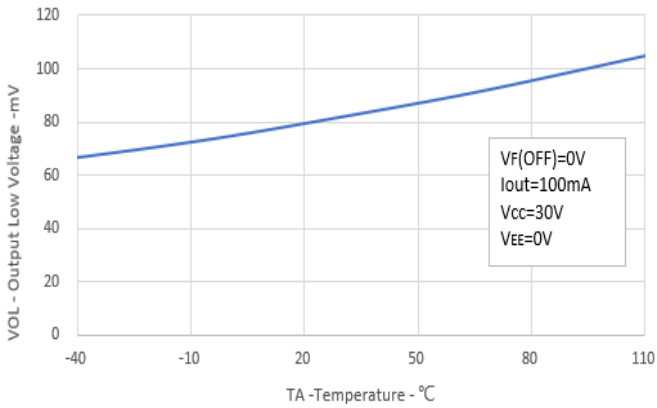

Fig.4 I_{CC} vs. Temperature

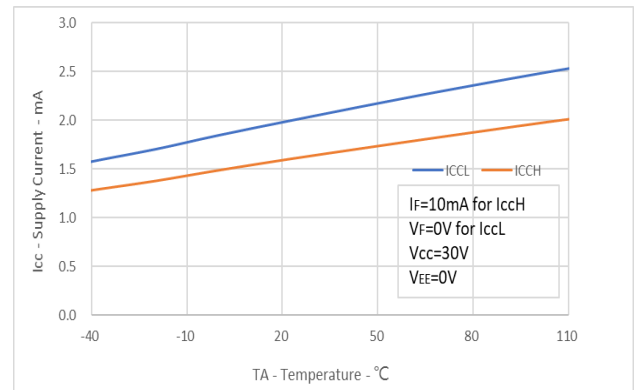

Fig.5 I_{CC} vs. V_{CC}

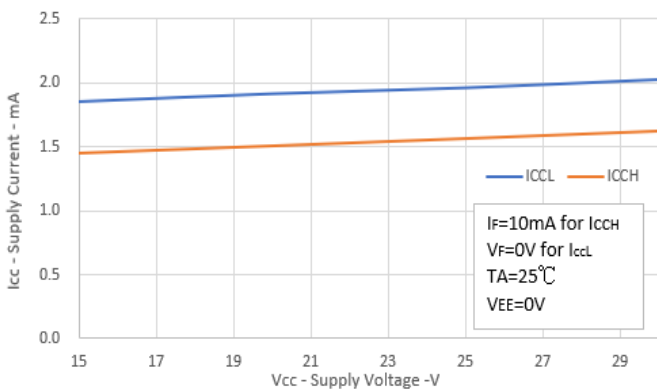
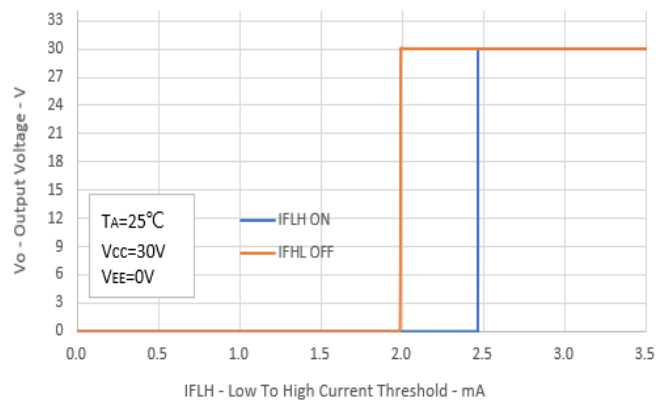

Fig. 6 IFLH Hysteresis



Rev: 1.1

Release Date: 2022/ 5/13



MPC-3120 Series

3.0A, Gate Driver Photo Coupler

Fig.7 IFLH vs. Temperature

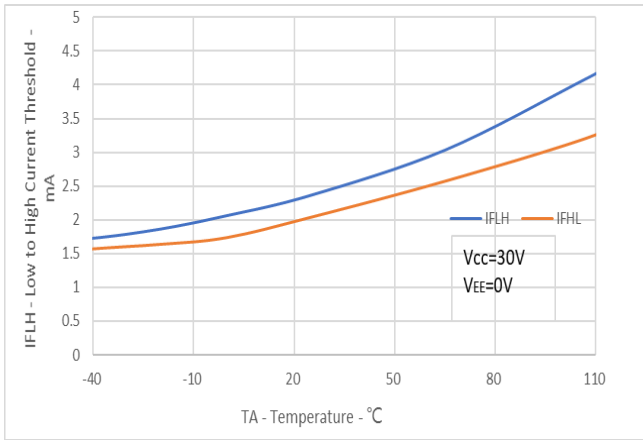

Fig.8 Propagation Delays vs. VCC

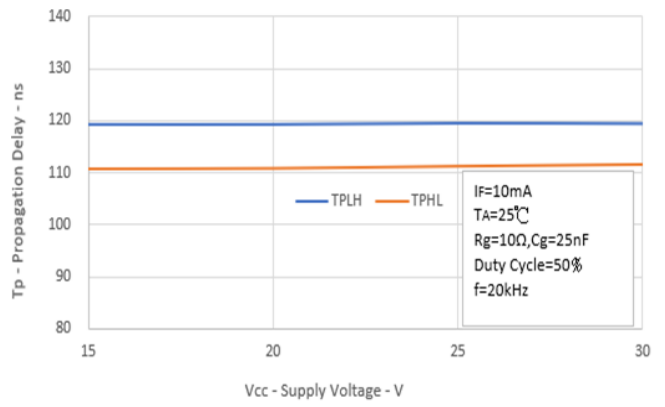

Fig.9 Propagation Delays vs. IF

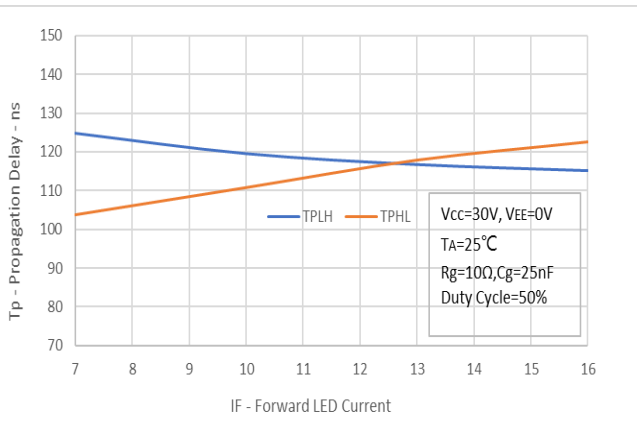

Fig.10 Propagation Delays vs. Temperature

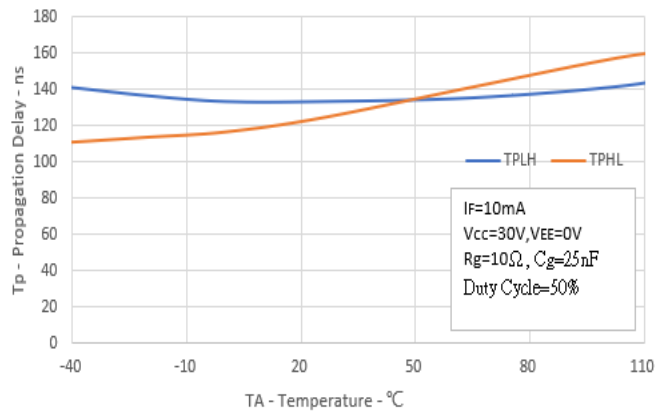

Fig.11 Propagation Delay vs Rg

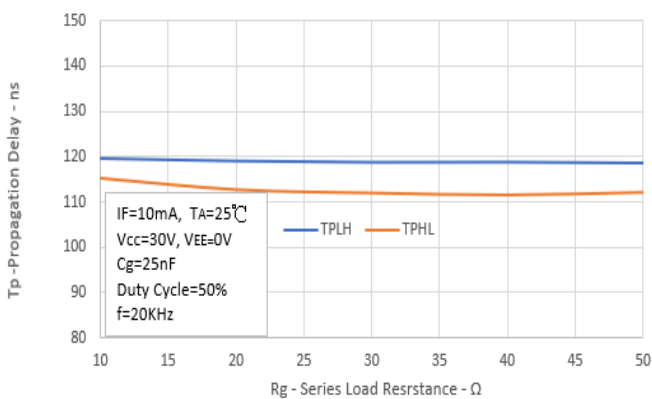
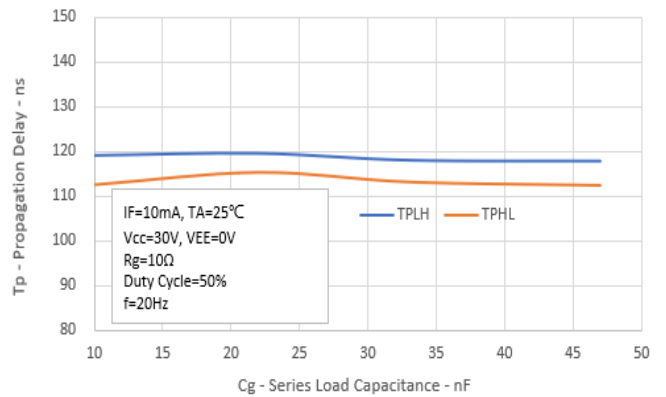

Fig. 12 Propagation Delay vs. Cg





MPC-3120 Series

3.0A, Gate Driver Photo Coupler

Fig.13 Input Current vs. Forward Voltage

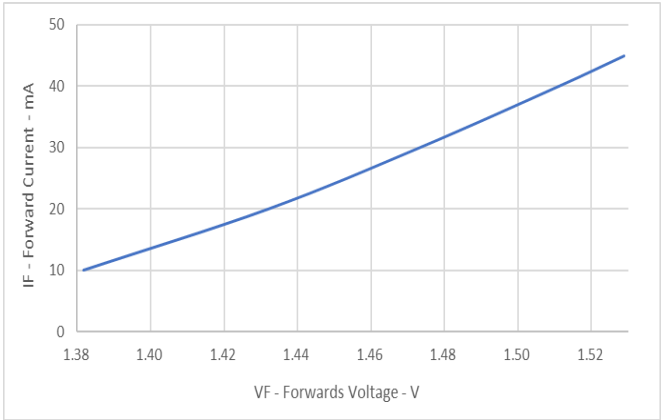



MPC-3120 Series

3.0A, Gate Driver Photo Coupler

PACKAGE DIMENSIONS (Dimensions in mm unless otherwise stated)

Standard DIP Type

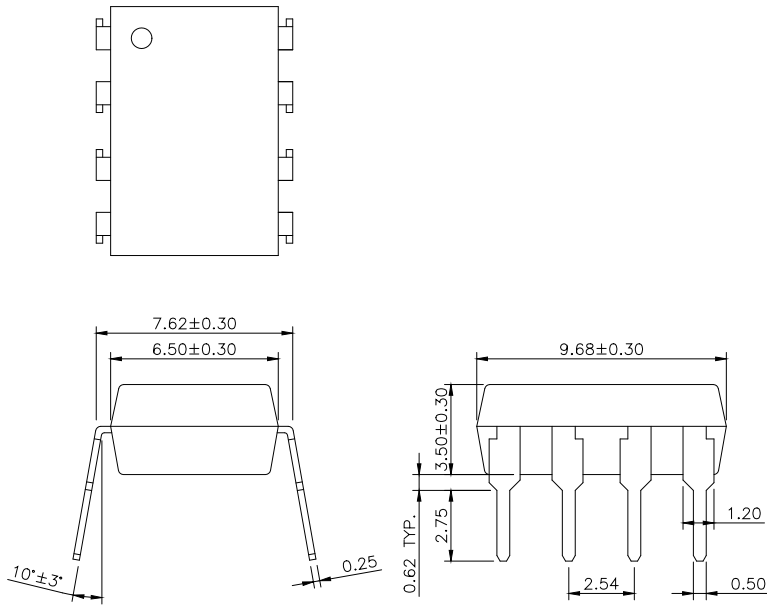

TOLERANCE : ± 0.2 mm

Surface Mount Type (Option S)

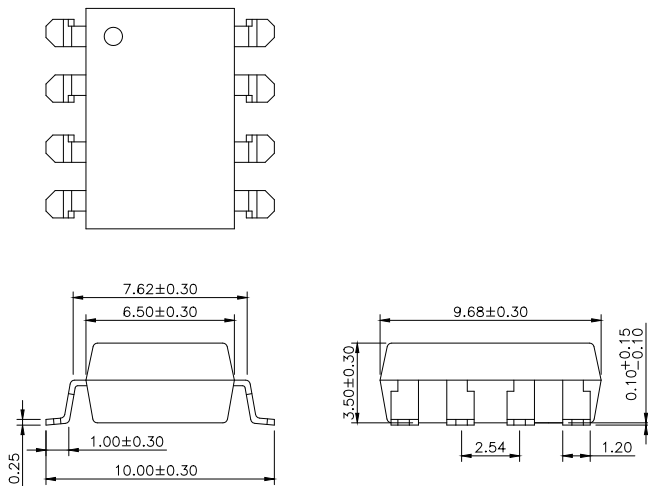

TOLERANCE : ± 0.2 mm

Rev: 1.1

Release Date: 2022/ 5/13



MPC-3120 Series

3.0A, Gate Driver Photo Coupler

Long Creepage Distance Type (Option M)

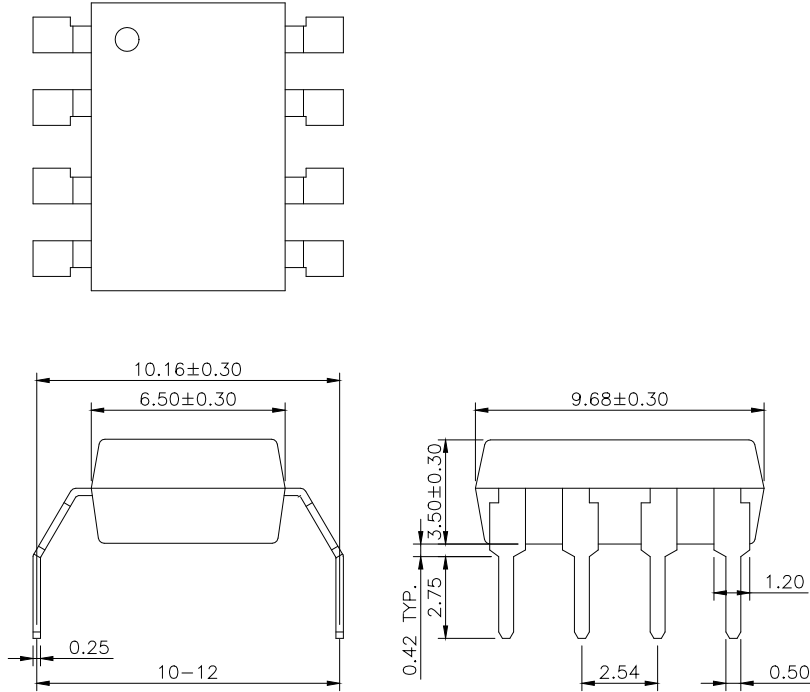

TOLERANCE : ±0.2mm

Long Creepage Distance For Surface Mount Type (Option SM)

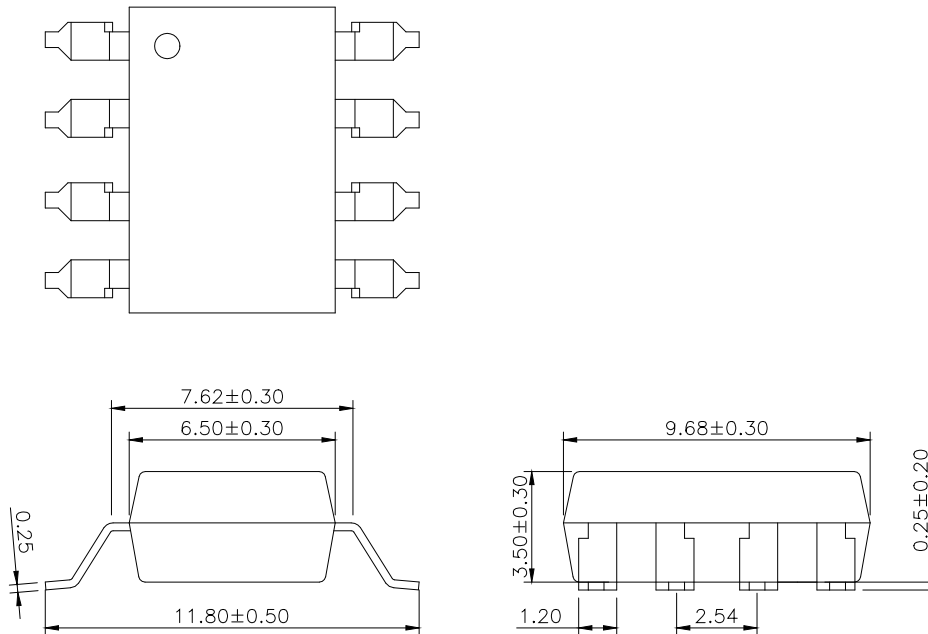

TOLERANCE : ±0.2mm

Rev: 1.1

Release Date: 2022/ 5/13



MPC-3120 Series

3.0A, Gate Driver Photo Coupler

MARKING INFORMATION



M : Company Abbr.
YY : Year date code
WW : 2-digit work week
3120 : Part Number
C : Factory identification mark
V : VDE Identification(Option)

ORDERING INFORMATION

MPC-3120XY-ZV

MPC – Company Abbr.
3120 – Part Number
X – UVLO Option (None / L)
Y – Lead Form Option (None / M / S / SM)
(None-7mm Clearance or M-10mm Clearance
or S-10mm Clearance or SM-11.8mm Clearance)
Z – Tape and Reel Option (None /T1/T2)
V – VDE Option (V or None)



Precautions for Soldering

IR Reflow soldering

One time soldering reflow is recommended within the condition of temperature and time profile shown below. Do not solder more than three times.

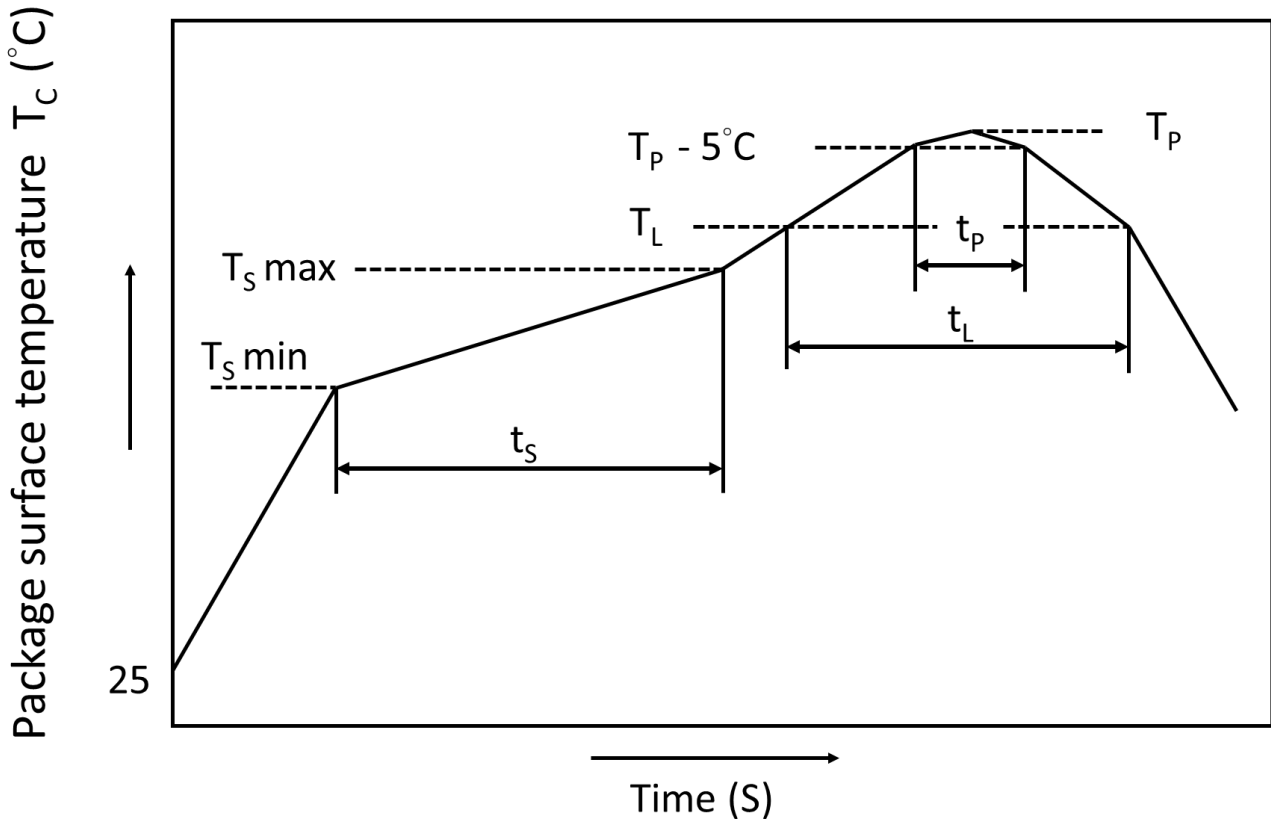

	Symbol	Min	Max	Unit
Preheat temperature	T_S	150	200	$^\circ\text{C}$
Preheat time	t_S	60	120	s
Ramp-up rate (T_L to T_P)			3	$^\circ\text{C/s}$
Liquidus temperature	T_L	217		$^\circ\text{C}$
Time above T_L	t_L	60	100	s
Peak Temperature	T_P		260	$^\circ\text{C}$
Time during which T_C is between ($T_P - 5$) and T_P	t_P		20	s
Ramp-down rate			6	$^\circ\text{C/s}$



DISCLAIMER

- WISELITE is continually improving the quality, reliability, function and design. WISELITE reserves the right to make changes without further notices.
- The characteristic curves shown in this datasheet are representing typical performance which are not guaranteed.
- WISELITE makes no warranty, representation or guarantee regarding the suitability of the products for any particular purpose or the continuing production of any product. To the maximum extent permitted by applicable law, WISELITE disclaims (a) any and all liability arising out of the application or use of any product, (b) any and all liability, including without limitation special, consequential or incidental damages, and (c) any and all implied warranties, including warranties of fitness for particular.
- The products shown in this publication are designed for the general use in electronic applications such as office automation, equipment, communications devices, audio/visual equipment, electrical application and instrumentation purpose, non-infringement and merchantability.
- This product is not intended to be used for military, aircraft, medical, life sustaining or lifesaving applications or any other application which can result in human injury or death.
- Please contact WISELITE sales agent for special application request.
- Immerge unit's body in solder paste is not recommended.
- Parameters provided in datasheets may vary in different applications and performance may vary over time. All operating parameters, including typical parameters, must be validated in each customer application by the customer's technical experts. Product specifications do not expand or otherwise modify WISELITE's terms and conditions of purchase, including but not limited to the warranty expressed therein.
- Discoloration might be occurred on the package surface after soldering, reflow or long-time use. It neither impacts the performance nor reliability.



MPC-3120 Series

3.0A, Gate Driver Photo Coupler

版本 Rev.	生效日期 Effective Date	作者 Applicant	內容 Change Description
1.0	2022/4/7	陳秉慈	新制訂
1.1	2022/5/13	陳秉慈	新增 Truth Table

单击下面可查看定价，库存，交付和生命周期等信息

[>>WISELITE\(皓光\)](#)