

General Description

The SN74HC/HCT238 decodes three binary weighted address inputs (A0, A1 and A2) to eight mutually exclusive outputs (Y0 to Y7). The device features three enable inputs ($\bar{E}1$ and $\bar{E}2$ and E3). Every output will be LOW unless $\bar{E}1$ and $\bar{E}2$ are LOW and E3 is HIGH. This multiple enable function allows easy parallel expansion to a 1-of-32 (5 to 32 lines) decoder with just four SN74HC/HCT238 ICs and one inverter. The SN74HC/HCT238 can be used as an eight output demultiplexer by using one of the active LOW enable inputs as the data input and the remaining enable inputs as strobes. Inputs include clamp diodes. This enables the use of current limiting resistors to interface inputs to voltages in excess of V_{CC} .

Features

- Input levels:
For SN74HC238: CMOS level
For SN74HCT238: TTL level
- Demultiplexing capability
- Multiple input enable for easy expansion
- Ideal for memory chip select decoding
- Active HIGH mutually exclusive outputs
- Specified from -40C to +105C
- Packaging information: DIP16/SOP16/TSSOP16

Ordering Information

型号	封装	丝印	包装	包装数量
SN74HC238N	DIP-16	74HC238N	管装	1000/ 盒
SN74HC238DTR	SOP-16	74HC238	编带	2500/ 盘
SN74HC238TDTR	TSSOP-16	74HC238	编带	3000/ 盘
SN74HCT238DTR	SOP-16	74HCT238	编带	2500/ 盘
SN74HCT238TDTR	TSSOP-16	74HCT238	编带	3000/ 盘

2 Block Diagram And Pin Description

2.1、Block Diagram

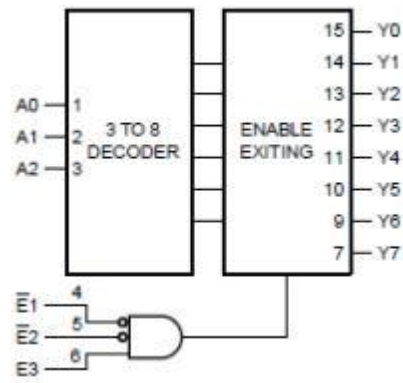

Figure 1. Logic symbol

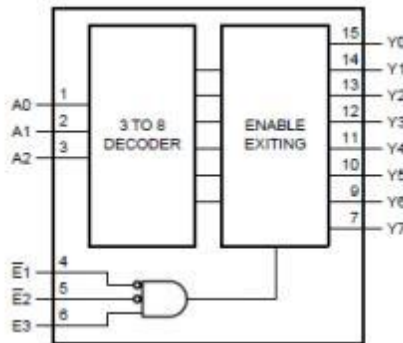

Figure 2. Functional diagram

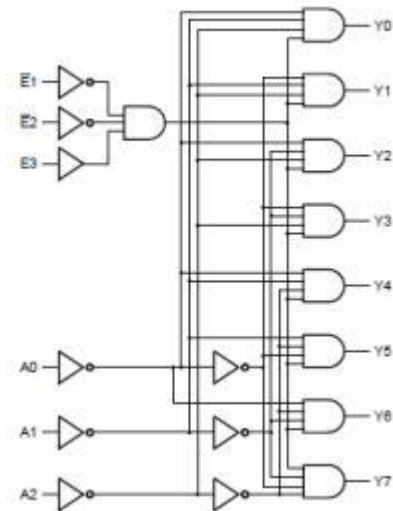
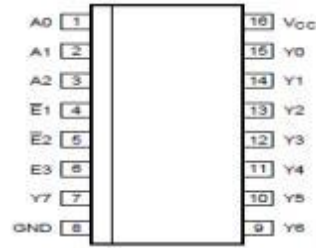

Figure 3. Logic diagram

2.2、Pin Configurations



2.3、Pin Description

Pin No.	Pin Name	Description
1	A0	address input
2	A1	address input
3	A2	address input
4	$\bar{E}1$	enable input (active LOW)
5	$\bar{E}2$	enable input (active LOW)
6	E3	enable input (active HIGH)
7	Y7	output (active HIGH)
8	GND	ground (0V)
9	Y6	output (active HIGH)
10	Y5	output (active HIGH)
11	Y4	output (active HIGH)
12	Y3	output (active HIGH)
13	Y2	output (active HIGH)
14	Y1	output (active HIGH)
15	Y0	output (active HIGH)
16	V _{CC}	supply voltage

2.4、Function Table

Input						Output							
$\bar{E}1$	$\bar{E}2$	E3	A0	A1	A2	Y0	Y1	Y2	Y3	Y4	Y5	Y6	Y7
H	X	X	X	X	X	L	L	L	L	L	L	L	L
X	H	X	X	X	X	L	L	L	L	L	L	L	L
X	X	L	X	X	X	L	L	L	L	L	L	L	L
L	L	H	L	L	L	H	L	L	L	L	L	L	L
L	L	H	H	L	L	L	H	L	L	L	L	L	L
L	L	H	L	H	L	L	L	H	L	L	L	L	L
L	L	H	H	H	L	L	L	L	H	L	L	L	L
L	L	H	L	L	H	L	L	L	L	H	L	L	L
L	L	H	H	L	H	L	L	L	L	L	H	L	L
L	L	H	L	H	H	L	L	L	L	L	L	H	L
L	L	H	H	H	H	L	L	L	L	L	L	L	H

Note: H=HIGH voltage level; L=LOW voltage level; X=don't care.

3 Electrical Parameter

3.1、Absolute Maximum Ratings

Parameter	Symbol	Conditions	Min.	Max.	Unit
supply voltage	V_{CC}	-	-0.5	+7.0	V
input clamping current	I_{IK}	$V_I < -0.5V$ or $V_I > V_{CC}+0.5V$	-	±20	mA
output clamping current	I_{OK}	$V_O < -0.5V$ or $V_O > V_{CC}+0.5V$	-	±20	mA
output current	I_O	$-0.5V < V_O < V_{CC}+0.5V$	-	±25	mA
supply current	I_{CC}	-	-	+50	mA
ground current	I_{GND}	-	-50	-	mA
storage temperature	T_{stg}	-	-65	+150	°C
total power dissipation	P_{tot}	-	-	500	mW
Soldering temperature	T_L	10s	DIP	245	°C
			SOP	250	°C

(Voltages are referenced to GND(ground=0V), unless otherwise specified.)

Note:

[1] For DIP16 packages: above 70°C the value of P_{tot} derates linearly with 12mW/K.

[2] For SOP16 packages: above 70°C the value of P_{tot} derates linearly with 8mW/K.

[3] For (T)SSOP16 packages: above 60°C the value of P_{tot} derates linearly with 5.5mW/K.

3.2、Recommended Operating Conditions

Parameter	Symbol	Conditions	Min.	Typ.	Max.	Unit
SN74HC238						
supply voltage	V_{CC}	-	2.0	5.0	6.0	V
input voltage	V_I	-	0	-	V_{CC}	V
output voltage	V_O	-	0	-	V_{CC}	V
input transition rise and fall rate	$\Delta t/\Delta V$	$V_{CC}=2.0V$	-	-	625	ns/V
		$V_{CC}=4.5V$	-	1.67	139	ns/V
		$V_{CC}=6.0V$	-	-	83	ns/V
ambient temperature	T_{amb}	-	-40	-	+105	°C
SN74HCT238						
supply voltage	V_{CC}	-	4.5	5.0	5.5	V
input voltage	V_I	-	0	-	V_{CC}	V
output voltage	V_O	-	0	-	V_{CC}	V
input transition rise and fall rate	$\Delta t/\Delta V$	$V_{CC}=4.5V$	-	1.67	139	ns/V
ambient temperature	T_{amb}	-	-40	-	+105	°C

3.3、Electrical Characteristics

3.3.1、DC Characteristics 1

($T_{amb}=25C$, voltages are referenced to GND (ground=0V), unless otherwise specified.)

Parameter	Symbol	Conditions	Min.	Typ.	Max.	Unit	
SN74HC238							
HIGH-level input voltage	V_{IH}	$V_{CC}=2.0V$	1.5	1.2	-	V	
		$V_{CC}=4.5V$	3.15	2.4	-	V	
		$V_{CC}=6.0V$	4.2	3.2	-	V	
LOW-level input voltage	V_{IL}	$V_{CC}=2.0V$	-	0.8	0.5	V	
		$V_{CC}=4.5V$	-	2.1	1.35	V	
		$V_{CC}=6.0V$	-	2.8	1.8	V	
HIGH-level output voltage	V_{OH}	$V_I = V_{IH} \text{ or } V_{IL}$	$I_O=-20\mu A; V_{CC}=2.0V$	1.9	2.0	-	V
			$I_O=-20\mu A; V_{CC}=4.5V$	4.4	4.5	-	V
			$I_O=-20\mu A; V_{CC}=6.0V$	5.9	6.0	-	V
			$I_O=-4.0mA; V_{CC}=4.5V$	3.98	4.32	-	V
			$I_O=-5.2mA; V_{CC}=6.0V$	5.48	5.81	-	V
LOW-level output voltage	V_{OL}	$V_I = V_{IH} \text{ or } V_{IL}$	$I_O=20\mu A; V_{CC}=2.0V$	-	0	0.1	V
			$I_O=20\mu A; V_{CC}=4.5V$	-	0	0.1	V
			$I_O=20\mu A; V_{CC}=6.0V$	-	0	0.1	V
			$I_O=4.0mA; V_{CC}=4.5V$	-	0.15	0.26	V
			$I_O=5.2mA; V_{CC}=6.0V$	-	0.16	0.26	V
input leakage current	I_I	$V_I=V_{CC} \text{ or } GND; V_{CC}=6.0V$	-	-	± 0.1	μA	
supply current	I_{CC}	$V_I=V_{CC} \text{ or } GND; I_O=0A; V_{CC}=6.0V$	-	-	8.0	μA	
input capacitance	C_I	-	-	3.5	-	pF	
SN74HCT238							
HIGH-level input voltage	V_{IH}	$V_{CC}=4.5V \text{ to } 5.5V$	2.0	1.6	-	V	
LOW-level input voltage	V_{IL}	$V_{CC}=4.5V \text{ to } 5.5V$	-	1.2	0.8	V	
HIGH-level output voltage	V_{OH}	$V_I = V_{IH} \text{ or } V_{IL}; V_{CC}=4.5V$	$I_O=-20\mu A$	4.4	4.5	-	V
			$I_O=-4.0mA$	3.98	4.32	-	V
LOW-level output voltage	V_{OL}	$V_I = V_{IH} \text{ or } V_{IL}; V_{CC}=4.5V$	$I_O=20\mu A$	-	0	0.1	V
			$I_O=4.0mA$	-	0.16	0.26	V
input leakage current	I_I	$V_I=V_{CC} \text{ or } GND; V_{CC}=5.5V$	-	-	± 0.1	μA	
supply current	I_{CC}	$V_I=V_{CC} \text{ or } GND; I_O=0A; V_{CC}=5.5V$	-	-	8.0	μA	
additional supply current	ΔI_{CC}	$V_I=V_{CC}-2.1V;$ other inputs at V_{CC} or GND; $I_O=0A;$ $V_{CC}=4.5V \text{ to } 5.5V$	An inputs	-	70	252	μA
			$\bar{E}1, \bar{E}2$ inputs	-	40	144	μA
			E3 input	-	145	522	μA
input capacitance	C_I	-	-	3.5	-	pF	

3.3.2、DC Characteristics 2

($T_{amb}=-40^{\circ}\text{C}$ to $+85^{\circ}\text{C}$, voltages are referenced to GND (ground=0V), unless otherwise specified.)

Parameter	Symbol	Conditions	Min.	Typ.	Max.	Unit	
SN74HC238							
HIGH-level input voltage	V_{IH}	$V_{CC}=2.0\text{V}$	1.5	-	-	V	
		$V_{CC}=4.5\text{V}$	3.15	-	-	V	
		$V_{CC}=6.0\text{V}$	4.2	-	-	V	
LOW-level input voltage	V_{IL}	$V_{CC}=2.0\text{V}$	-	-	0.5	V	
		$V_{CC}=4.5\text{V}$	-	-	1.35	V	
		$V_{CC}=6.0\text{V}$	-	-	1.8	V	
HIGH-level output voltage	V_{OH}	$V_I = V_{IH}$ or V_{IL}	$I_O=-20\mu\text{A}; V_{CC}=2.0\text{V}$	1.9	-	-	V
			$I_O=-20\mu\text{A}; V_{CC}=4.5\text{V}$	4.4	-	-	V
			$I_O=-20\mu\text{A}; V_{CC}=6.0\text{V}$	5.9	-	-	V
			$I_O=-4.0\text{mA}; V_{CC}=4.5\text{V}$	3.84	-	-	V
			$I_O=-5.2\text{mA}; V_{CC}=6.0\text{V}$	5.34	-	-	V
LOW-level output voltage	V_{OL}	$V_I = V_{IH}$ or V_{IL}	$I_O=20\mu\text{A}; V_{CC}=2.0\text{V}$	-	-	0.1	V
			$I_O=20\mu\text{A}; V_{CC}=4.5\text{V}$	-	-	0.1	V
			$I_O=20\mu\text{A}; V_{CC}=6.0\text{V}$	-	-	0.1	V
			$I_O=4.0\text{mA}; V_{CC}=4.5\text{V}$	-	-	0.33	V
			$I_O=5.2\text{mA}; V_{CC}=6.0\text{V}$	-	-	0.33	V
input leakage current	I_I	$V_I=V_{CC}$ or GND; $V_{CC}=6.0\text{V}$	-	-	± 1.0	μA	
supply current	I_{CC}	$V_I=V_{CC}$ or GND; $I_O=0\text{A}; V_{CC}=6.0\text{V}$	-	-	80	μA	
SN74HCT238							
HIGH-level input voltage	V_{IH}	$V_{CC}=4.5\text{V}$ to 5.5V	2.0	-	-	V	
LOW-level input voltage	V_{IL}	$V_{CC}=4.5\text{V}$ to 5.5V	-	-	0.8	V	
HIGH-level output voltage	V_{OH}	$V_I = V_{IH}$ or $V_{IL}; V_{CC}=4.5\text{V}$	$I_O=-20\mu\text{A}$	4.4	-	-	V
			$I_O=-4.0\text{mA}$	3.84	-	-	V
LOW-level output voltage	V_{OL}	$V_I = V_{IH}$ or $V_{IL}; V_{CC}=4.5\text{V}$	$I_O=20\mu\text{A}$	-	-	0.1	V
			$I_O=4.0\text{mA}$	-	-	0.33	V
input leakage current	I_I	$V_I=V_{CC}$ or GND; $V_{CC}=5.5\text{V}$	-	-	± 1.0	μA	
supply current	I_{CC}	$V_I=V_{CC}$ or GND; $I_O=0\text{A}; V_{CC}=5.5\text{V}$	-	-	80	μA	
additional supply current	ΔI_{CC}	$V_I=V_{CC}-2.1\text{V};$ other inputs at V_{CC} or GND; $I_O=0\text{A};$ $V_{CC}=4.5\text{V}$ to 5.5V	An inputs	-	-	315	μA
			$\bar{E}1, \bar{E}2$ inputs	-	-	180	μA
			E3 input	-	-	653	μA

3.3.4、AC Characteristics 1

(T_{amb}=25°C, voltages are referenced to GND (ground=0V), unless otherwise specified.)

Parameter	Symbol	Conditions	Min.	Typ.	Max.	Unit	
SN74HC238							
propagation delay	t _{pd}	An to Y _n ; see Figure 5	V _{CC} =2.0V	-	47	150	ns
			V _{CC} =4.5V	-	17	30	ns
			V _{CC} =5.0V; C _L =15pF	-	14	-	ns
			V _{CC} =6.0V	-	14	26	ns
		E3 to Y _n ; see Figure 5	V _{CC} =2.0V	-	52	160	ns
			V _{CC} =4.5V	-	19	32	ns
			V _{CC} =5.0V; C _L =15pF	-	16	-	ns
			V _{CC} =6.0V	-	15	27	ns
		E _n to Y _n ; see Figure 6	V _{CC} =2.0V	-	50	155	ns
			V _{CC} =4.5V	-	18	31	ns
			V _{CC} =5.0V; C _L =15pF	-	17	-	ns
			V _{CC} =6.0V	-	14	26	ns
transition time	t _t	see Figure 5, 6	V _{CC} =2.0V	-	19	75	ns
			V _{CC} =4.5V	-	7	15	ns
			V _{CC} =6.0V	-	6	13	ns
power dissipation capacitance	C _{PD}	per package; V _I =GND to V _{CC}	-	72	-	pF	
SN74HCT238							
propagation delay	t _{pd}	An to Y _n ; see Figure 5	V _{CC} =4.5V	-	19	35	ns
			V _{CC} =5.0V; C _L =15pF	-	18	-	ns
		E3 to Y _n ; see Figure 5	V _{CC} =4.5V	-	20	37	ns
			V _{CC} =5.0V; C _L =15pF	-	20	-	ns
		E _n to Y _n ; see Figure 6	V _{CC} =4.5V	-	20	35	ns
			V _{CC} =5.0V; C _L =15pF	-	21	-	ns
transition time	t _t	V _{CC} =4.5V; see Figure 5, 6	-	7	15	ns	
power dissipation capacitance	C _{PD}	per package; V _I =GND to V _{CC} - 1.5V	-	76	-	pF	

Note:

[1] t_{pd} is the same as t_{PLH} and t_{PHL}.

[2] t_t is the same as t_{THL} and t_{TLH}.

[3] C_{PD} is used to determine the dynamic power dissipation (P_D in uW).

$$P_D = C_{PD} \times V_{CC}^2 \times f_i \times N + \sum (C_L \times V_{CC}^2 \times f_o) \text{ where:}$$

f_i=input frequency in MHz;

f_o=output frequency in MHz;

C_L=output load capacitance in pF;

V_{CC}=supply voltage in V;

N=number of inputs switching;

$\sum (C_L \times V_{CC}^2 \times f_o)$ =sum of outputs.

3.3.5、AC Characteristics 2

($T_{amb} = -40^{\circ}\text{C}$ to $+85^{\circ}\text{C}$, voltages are referenced to GND (ground=0V), unless otherwise specified.)

Parameter	Symbol	Conditions	Min.	Typ.	Max.	Unit	
SN74HC238							
propagation delay	t_{pd}	An to Yn; see Figure 5	$V_{CC}=2.0\text{V}$	-	-	190	ns
			$V_{CC}=4.5\text{V}$	-	-	38	ns
			$V_{CC}=6.0\text{V}$	-	-	33	ns
		E3 to Yn; see Figure 5	$V_{CC}=2.0\text{V}$	-	-	200	ns
			$V_{CC}=4.5\text{V}$	-	-	40	ns
			$V_{CC}=6.0\text{V}$	-	-	34	ns
		$\bar{E}n$ to Yn; see Figure 6	$V_{CC}=2.0\text{V}$	-	-	195	ns
			$V_{CC}=4.5\text{V}$	-	-	39	ns
			$V_{CC}=6.0\text{V}$	-	-	33	ns
transition time	t_t	see Figure 5, 6	$V_{CC}=2.0\text{V}$	-	-	95	ns
			$V_{CC}=4.5\text{V}$	-	-	19	ns
			$V_{CC}=6.0\text{V}$	-	-	16	ns
SN74HCT238							
propagation delay	t_{pd}	An to Yn; see Figure 5	$V_{CC}=4.5\text{V}$	-	-	44	ns
		E3 to Yn; see Figure 5	$V_{CC}=4.5\text{V}$	-	-	46	ns
		$\bar{E}n$ to Yn; see Figure 6	$V_{CC}=4.5\text{V}$	-	-	44	ns
transition time	t_t	$V_{CC}=4.5\text{V}$; see Figure 5, 6		-	-	19	ns

Note:

[1] t_{pd} is the same as t_{PLH} and t_{PHL} .

[2] t_t is the same as t_{THL} and t_{TLH} .

3.3.6、AC Characteristics 3

($T_{amb}=-40C$ to $+105C$, voltages are referenced to GND (ground=0V), unless otherwise specified.)

Parameter	Symbol	Conditions	Min.	Typ.	Max.	Unit	
SN74HC238							
propagation delay	t_{pd}	An to Yn; see Figure 5	$V_{CC}=2.0V$	-	-	225	ns
			$V_{CC}=4.5V$	-	-	45	ns
			$V_{CC}=6.0V$	-	-	38	ns
		E3 to Yn; see Figure 5	$V_{CC}=2.0V$	-	-	240	ns
			$V_{CC}=4.5V$	-	-	48	ns
			$V_{CC}=6.0V$	-	-	41	ns
		$\bar{E}n$ to Yn; see Figure 6	$V_{CC}=2.0V$	-	-	235	ns
			$V_{CC}=4.5V$	-	-	47	ns
			$V_{CC}=6.0V$	-	-	40	ns
transition time	t_t	see Figure 5, 6	$V_{CC}=2.0V$	-	-	110	ns
			$V_{CC}=4.5V$	-	-	22	ns
			$V_{CC}=6.0V$	-	-	19	ns
SN74HCT238							
propagation delay	t_{pd}	An to Yn; see Figure 5	$V_{CC}=4.5V$	-	-	53	ns
		E3 to Yn; see Figure 5	$V_{CC}=4.5V$	-	-	56	ns
		$\bar{E}n$ to Yn; see Figure 6	$V_{CC}=4.5V$	-	-	53	ns
transition time	t_t	$V_{CC}=4.5V$; see Figure 5, 6		-	-	22	ns

Note:

[1] t_{pd} is the same as t_{PLH} and t_{PHL} .

[2] t_t is the same as t_{THL} and t_{TLH} .

4 Testing Circuit

4.1 AC Testing Circuit 1

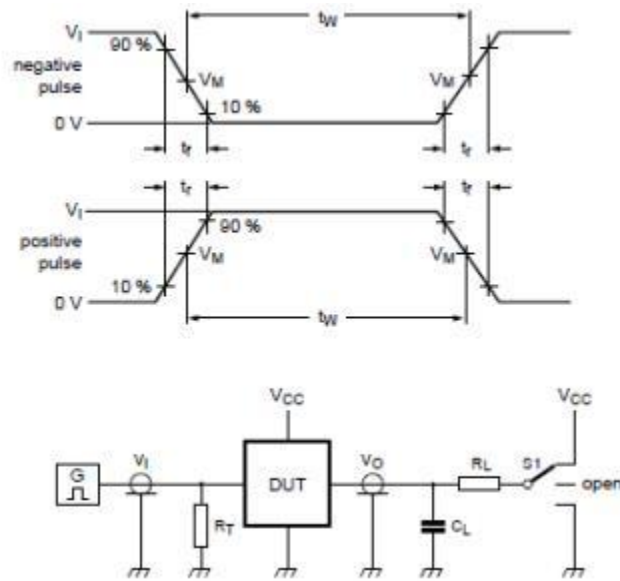

Figure 4. Test circuit for measuring switching times

Definitions for test circuit:

C_L =Load capacitance including jig and probe capacitance.

R_T =Termination resistance should be equal to the output impedance Z_o of the pulse generator. R_L =Load resistance.

$S1$ =Test selection switch.

4.2、AC Testing Waveform

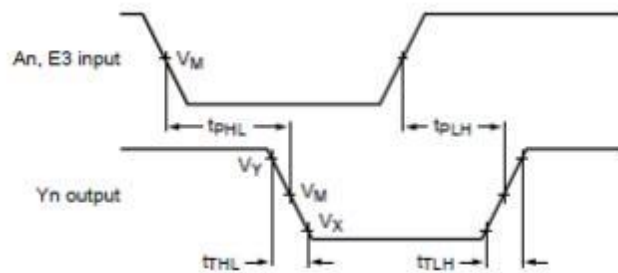

Figure 5. Input (An, E3) to output (Yn) propagation delays and output transition times

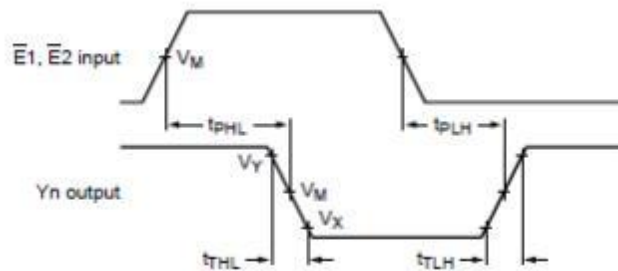

Figure 6. Input ($\bar{E}1$, $\bar{E}2$) to output (Yn) propagation delays and output transition times

4.3、Measurement Points

Type	Input	Output		
	V_M	V_M	V_X	V_Y
SN74HC238	$0.5 \times V_{CC}$	$0.5 \times V_{CC}$	$0.1 \times V_{CC}$	$0.9 \times V_{CC}$
SN74HCT238	1.3V	1.3V	$0.1 \times V_{CC}$	$0.9 \times V_{CC}$

4.4、Test Data

Type	Input		Load		S1 position
	V_I	t_r, t_f	C_L	R_L	t_{PHL}, t_{PLH}
SN74HC238	V_{CC}	6ns	15pF, 50pF	1kΩ	open
SN74HCT238	3V	6ns	15pF, 50pF	1kΩ	open

5 Package Information

5.1 DIP14

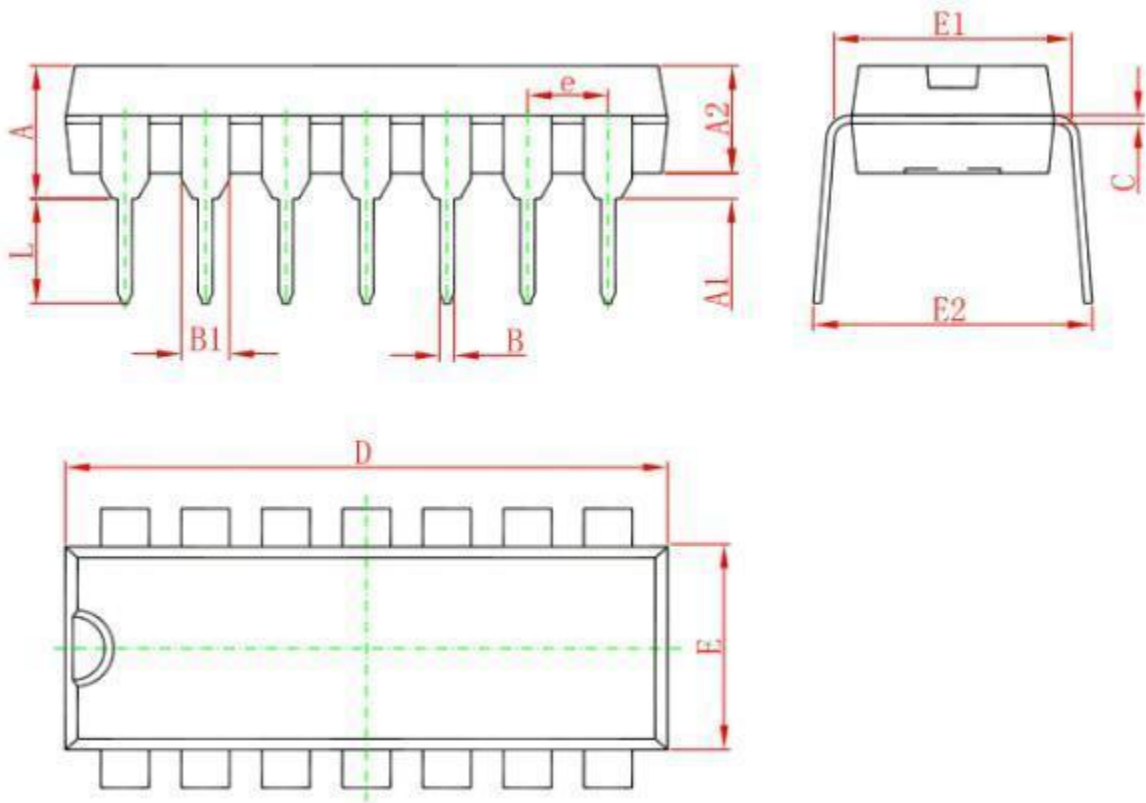

Symbol	Dimensions In Millimeters		Dimensions In Inches	
	Min	Max	Min	Max
A	3.710	4.310	0.146	0.170
A1	0.510		0.020	
A2	3.200	3.600	0.126	0.142
B	0.380	0.570	0.015	0.022
B1	1.524 (BSC)		0.060 (BSC)	
C	0.204	0.360	0.008	0.014
D	18.800	19.200	0.740	0.756
E	6.200	6.600	0.244	0.260
E1	7.320	7.920	0.288	0.312
e	2.540 (BSC)		0.100 (BSC)	
L	3.000	3.600	0.118	0.142
E2	8.400	9.000	0.331	0.354

5.2、SOP16

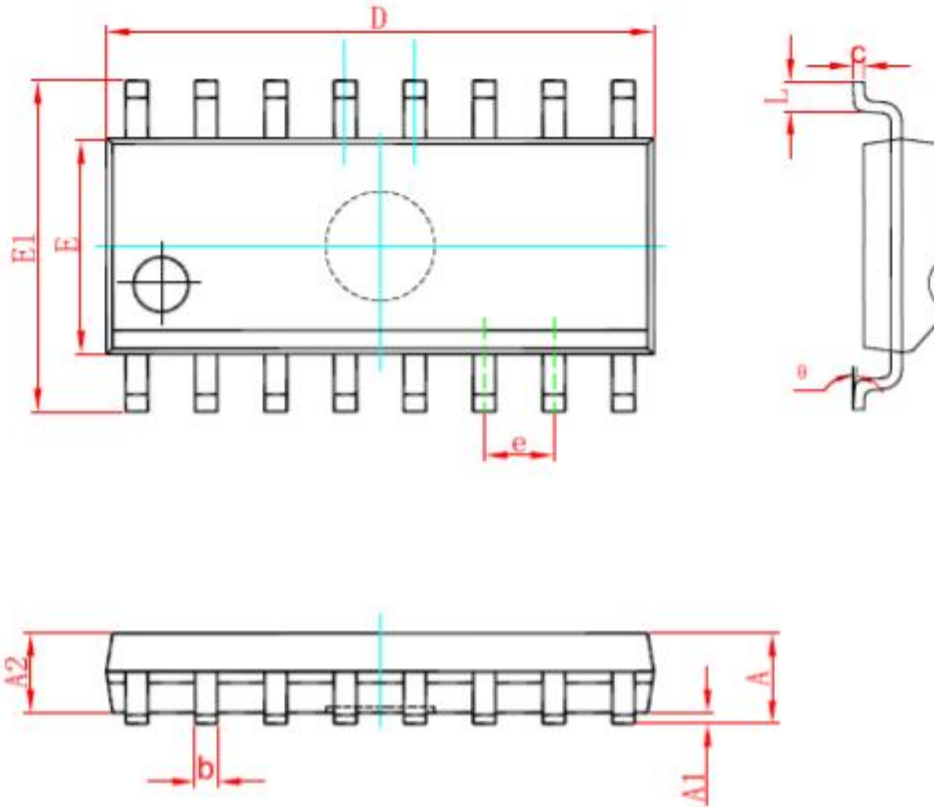

Symbol	Dimensions In Millimeters		Dimensions In Inches	
	Min	Max	Min	Max
A	1.350	1.750	0.053	0.069
A1	0.100	0.250	0.004	0.010
A2	1.350	1.550	0.053	0.061
b	0.330	0.510	0.013	0.020
c	0.170	0.250	0.007	0.010
D	9.800	10.200	0.386	0.402
E	3.800	4.000	0.150	0.157
E1	5.800	6.200	0.228	0.244
e	1.270 (BSC)		0.050 (BSC)	
L	0.400	1.270	0.016	0.050
θ	0°	8°	0°	8°

5.3、TSSOP16

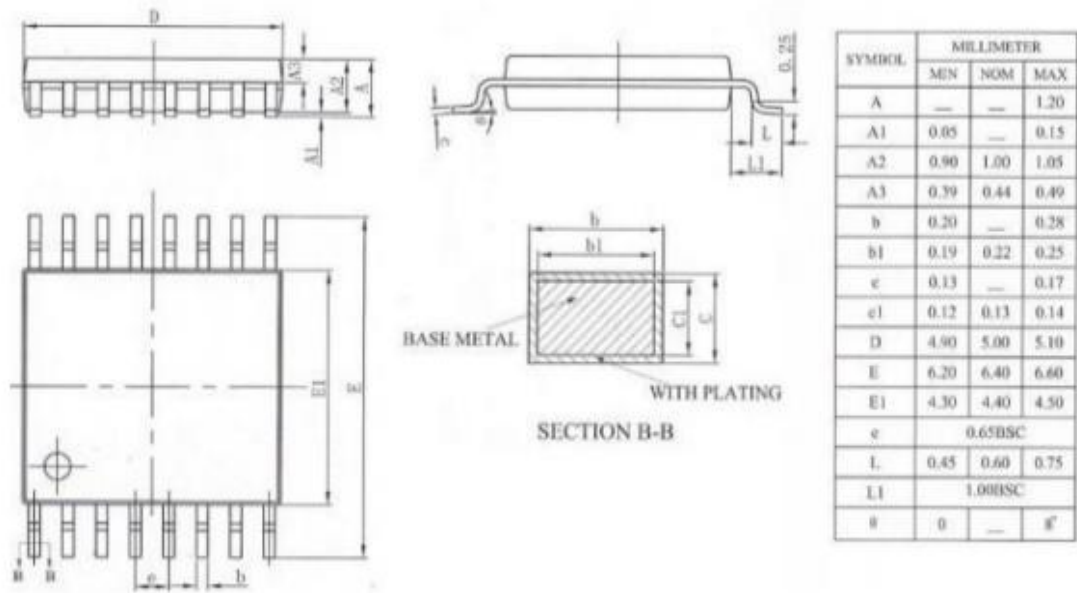

Statement:

- ◇ Shenzhen xinbole electronics co., ltd. reserves the right to change the product specifications, without notice! Before placing an order, the customer needs to confirm whether the information obtained is the latest version, and verify the integrity of the relevant information.
- ◇ Any semiconductor product is liable to fail or malfunction under certain conditions, and the buyer shall be responsible for complying with safety standards in the system design and whole machine manufacturing using Shenzhen xinbole electronics co., ltd products, and take appropriate security measures to avoid the potential risk of failure may result in personal injury or property losses of the situation occurred!
- ◇ Product performance is never ending, Shenzhen xinbole electronics co., ltd will be dedicated to provide customers with better performance, better quality of integrated circuit products.

单击下面可查看定价，库存，交付和生命周期等信息

[>>XBLW\(芯伯乐\)](#)