

General Description

The **MC33063** is a monolithic control circuit containing the primary functions required for DC-to-DC converters. This device consists of an internal temperature compensated reference (1.25V), comparator, controlled duty cycle oscillator with an active current limit circuit, driver and high current output switch. The IC is specifically designed to be used in Step-Down and Step-Up and Voltage-Inverting applications with a minimum number of external components.

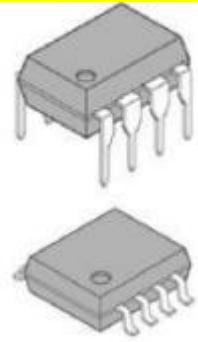

The **MC33063** is available in DIP8 and SOP8 package.

Features

- Operation from 3.0V to 40V Input
- Low Standby Current
- Current Limiting
- Output Switch Current to 1.5A
- Output Voltage Adjustable
- Frequency Operation to 100kHz
- Precision 2% Reference

Functional Block Diagram

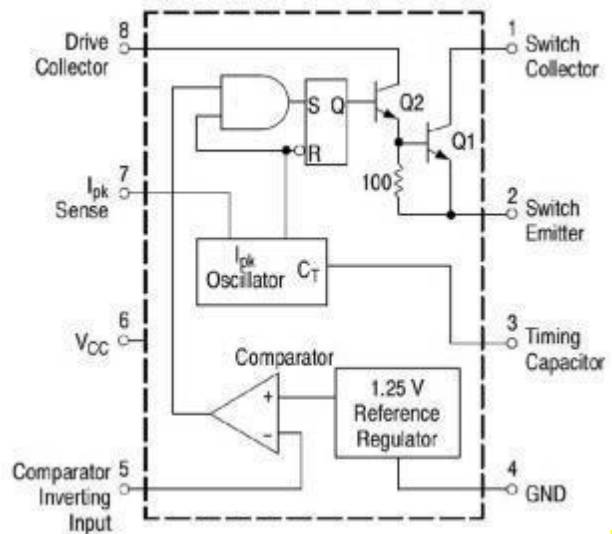

Ordering Information

DEVICE	Package Type	MARKING	Packing	Packing QTY
XBLW MC33063ADTR	SOP-8	MC33063A	Tape	2500/Reel

Pin Configuration

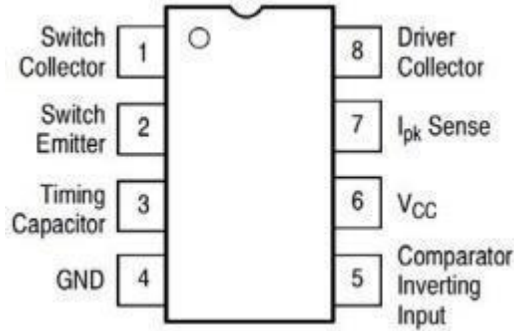

Pin Description

Pin Number	Pin Name	Function Description	Pin Number	Pin Name	Function Description
1	SC	Switch collector	5	FB	Comparator inverting input
2	SE	Switch emitter	6	V _{CC}	Input voltage
3	CT	Timing capacitor	7	I _{pk}	I _{pk} sense
4	GND	Ground	8	DC	Drive collector

Absolute Maximum Ratings (Ta= 25 ° C)

Parameter Name	Symbol	Value	Unit
Power Supply Voltage	V _{CC}	40	V
Comparator Input Voltage Range	V _{IR}	-0.3~40	V
Switch Collector Voltage	V _C (switch)	40	V
Switch Emitter Voltage (V _{Pin1} =40V)	V _E (switch)	40	V
Switch Collector to Emitter Voltage	V _{CE} (switch)	40	V
Driver Collector Voltage	V _C (drive)	40	V
Driver Collector Current	I _C (drive)	100	mA
Switch Current	I _{SW}	1.5	A
Power Dissipation	DIP8	1.25	W
	SOP8	625	mW
Operating Ambient Temperature Range	T _a	0~70	°C
Storage Temperature Range	T _{stg}	-65~150	°C

Electrical Characteristics (Unless otherwise noted , V_{CC}=5 .0 V, Ta=0~70 ° C)

Parameter Name	Symbol	Min	Typ	Max	Unit
OSCILLATOR					
Frequency (V _{pin5} =0V,CT=1.0nF, Ta=25°C)	f _{osc}	24	33	42	kHz
Charge Current (V _{CC} =5.0~40V, Ta=25°C)	I _{chg}	24	35	42	PA
Discharge Current (V _{CC} =5.0~40V, Ta=25°C)	I _{dischg}	140	220	260	PA
Discharge to Charge Current Ratio (Pin7 to V _{CC} , Ta=25°C)	I _{dischg} /I _{chg}	5.2	6.5	7.5	
Current limit Sense Voltage (I _{chg} =I _{dischg} , Ta=25°C)	V _{ipk} (sense)	250	300	350	mA

OUTPUT SWITCH					
Saturation Voltage, Darlington Connection (ISW=1.0A, Pins 1,8 Connected)	$V_{CE(sat)}$		1.0	1.3	V
Saturation Voltage, Darlington Connection (ISW=1.0A, Rpin 8=82Ω to Vcc, Forced $\beta \approx 20$)	$V_{CE(sat)}$		0.45	0.7	V
DC Current Gain (ISW=1.0A, VCE=5.0V, Ta=25°C)	hFE	50	75		
Collector Off-State Current (VCE=40V)	Ic(off)		0.01	100	PA
COMPARATOR					
Threshold Voltage (Ta=25°C)	V_{th}	1.225	1.25	1.275	V
Threshold Voltage (Ta=0~70°C)		1.21		1.29	
Threshold Voltage Line Regulation (Vcc=3.0~40V)	Regline		1.4	5.0	mV
Input Bias Current(Vin=0V)	I_{IB}		-20	-400	nA
TOTAL DEVICE					
Supply Current (Vcc=5.0~40V, CT=1.0nF, Pin7=Vcc, Vpin5>Vth, pin2=Gnd, Remaining Pins Open)	Icc			4.0	mA

Characteristics Curves

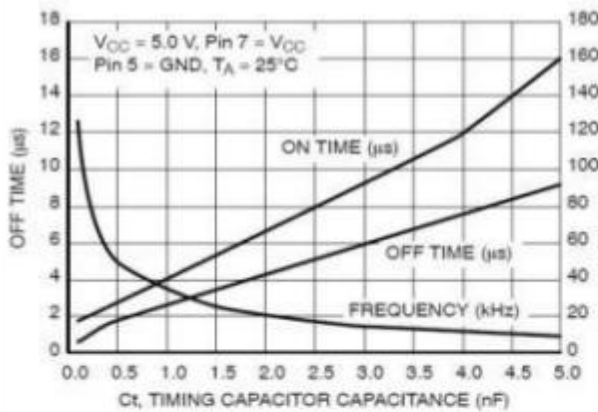

Oscillator Frequency

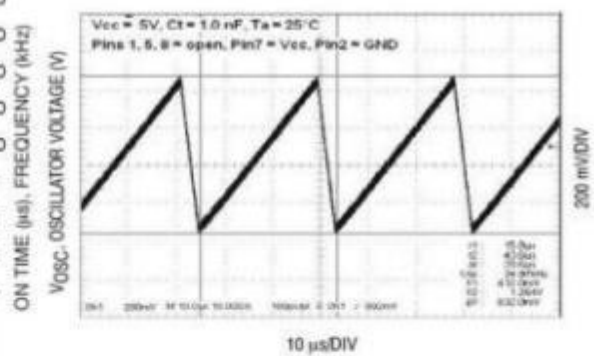

Timing Capacitor Waveform

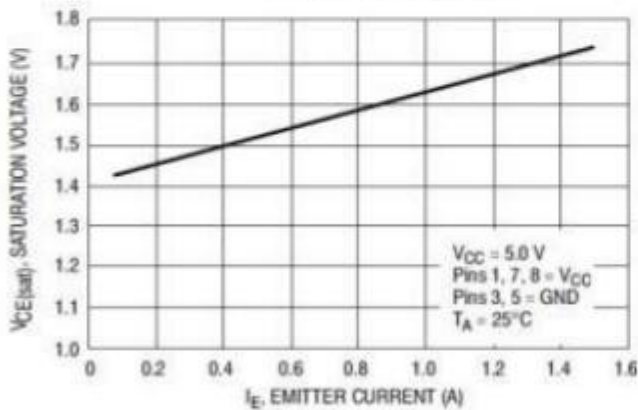

Emitter Follower Configuration Output

Saturation Voltage Versus Emitter Current

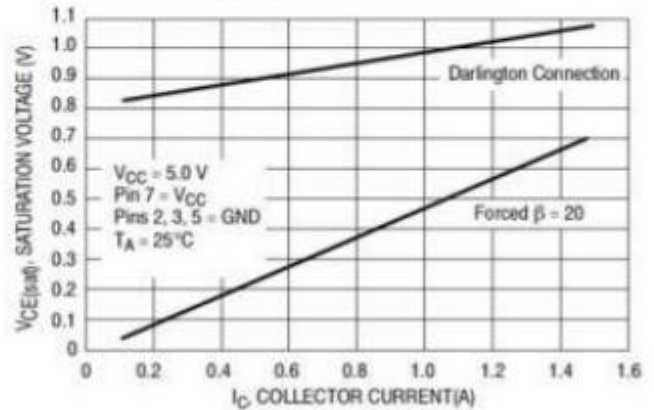

Common Emitter Configuration Output

Switch Saturation Voltage Versus Collector Current

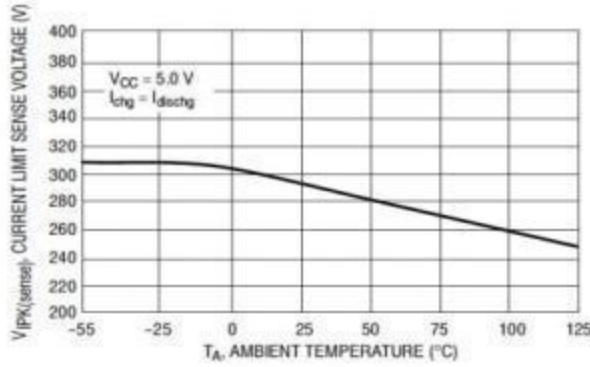

Current Limit Sense Voltage Versus Temperature

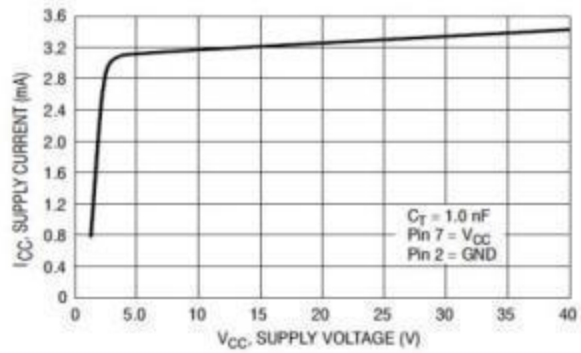

Standby Supply Current Versus Supply Voltage

Typical Application

1. Step-Up Converter

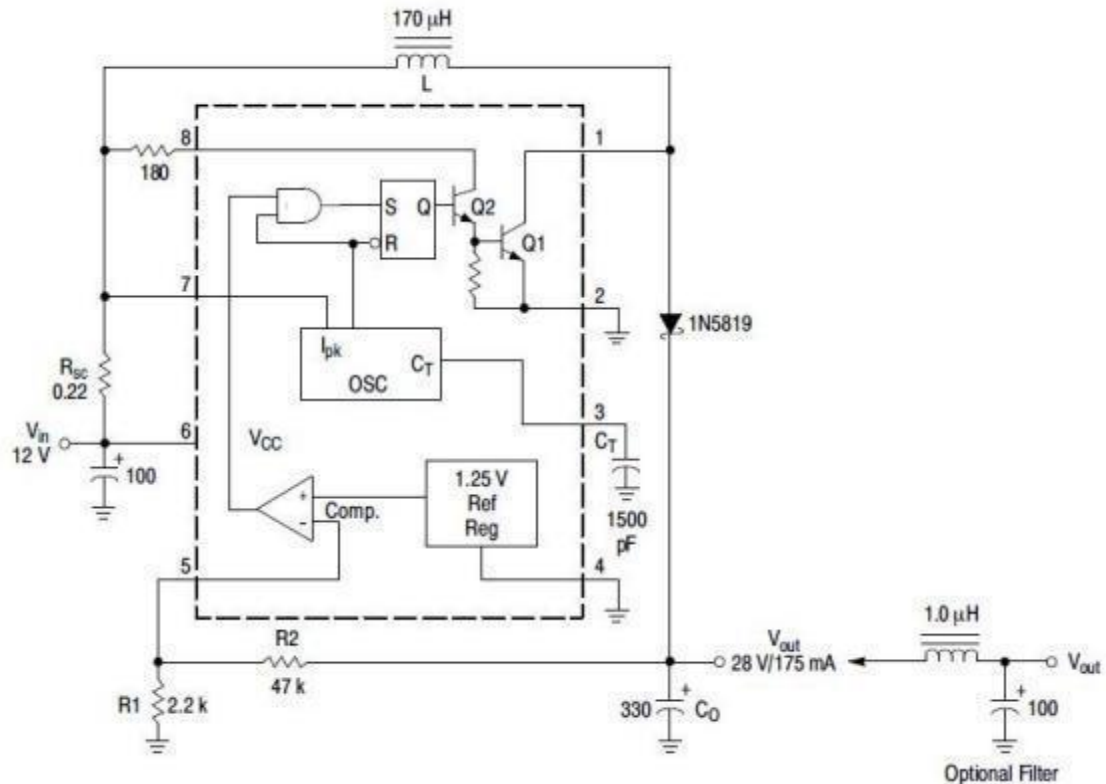

Test	Conditions	Results
Line Regulation	V _{in} =8.0V~ 16V, I _o = 175mA	30mV=±0.05%
Load Regulation	V _{in} = 12V, I _o =75mA~ 175mA	10mV=±0.017%
Output Ripple	V _{in} = 12V, I _o = 175mA	400mV _{pp}
Efficiency	V _{in} =12V, I _o = 175mA	87.7%
Output Ripple With Optional Filter	V _{in} =12V, I _o = 175mA	40mV _{pp}

2. Step-Down Converter

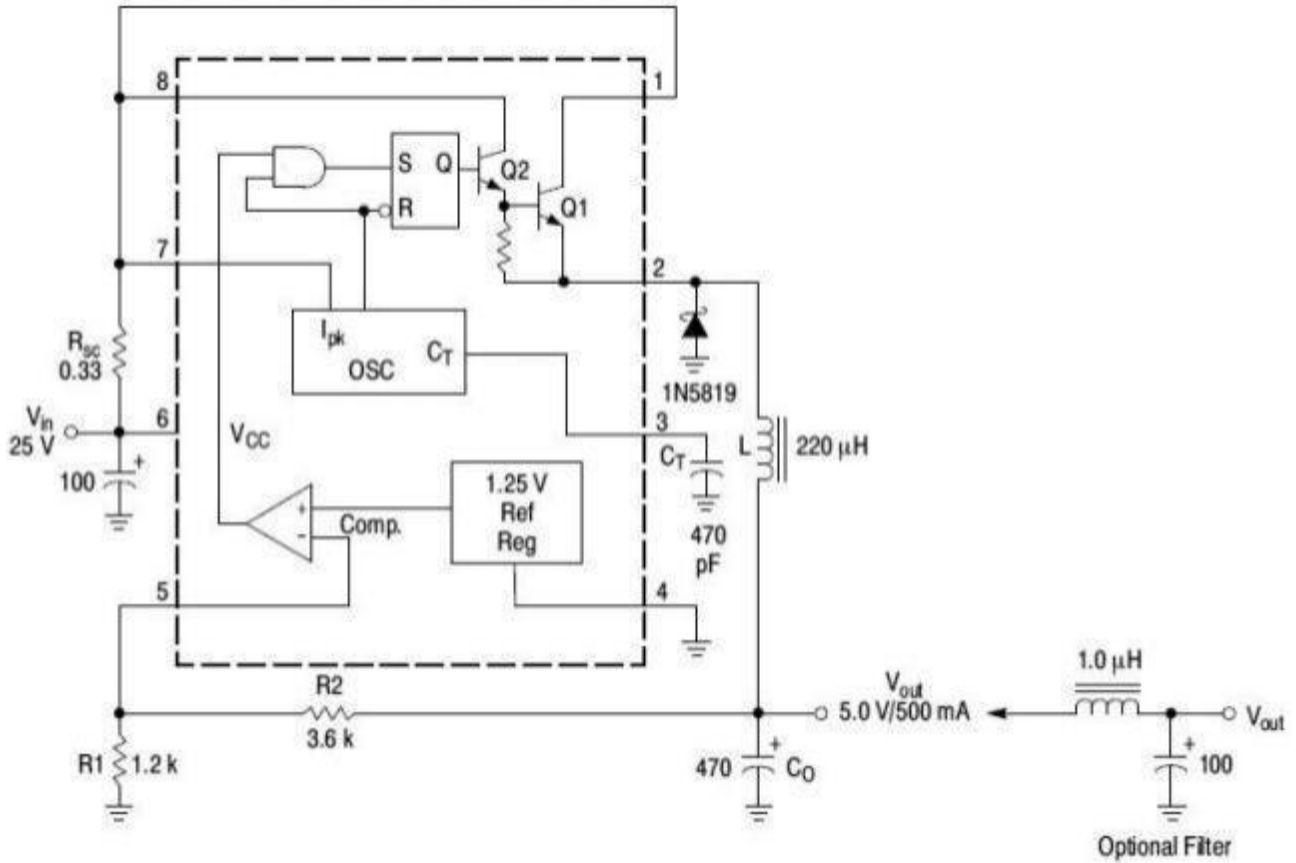

Test	Conditions	Results
Line Regulation	$V_{in}=15V\sim 25V, I_o=500mA$	$12mV=\pm 0.12\%$
Load Regulation	$V_{in}=25V, I_o=50mA\sim 500mA$	$3.0mV=\pm 0.03\%$
Output Ripple	$V_{in}=25V, I_o=500mA$	120mVpp
Short Circuit Current	$V_{in}=25V, R_L=0.1\Omega$	1.1A
Efficiency	$V_{in}=25V, I_o=500mA$	83.7%
Output Ripple With Optional Filter	$V_{in}=25V, I_o=500mA$	40mVpp

3. Voltage Inverting Converter

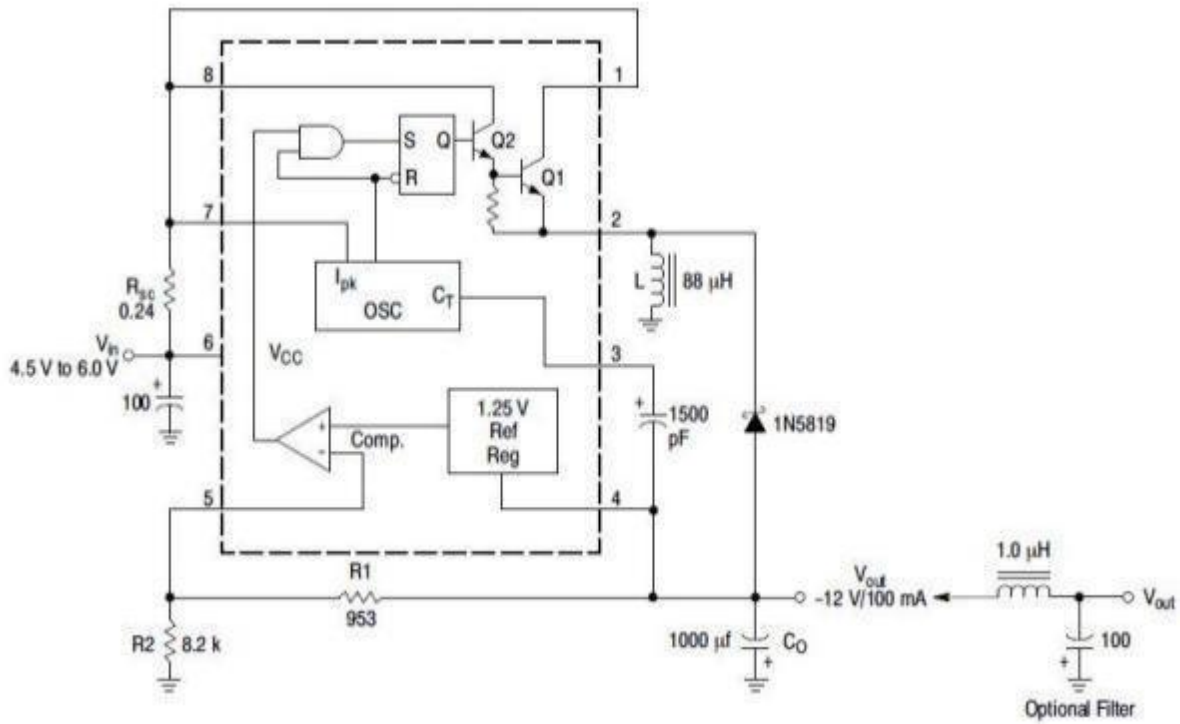

Test	Conditions	Results
Line Regulation	$V_{in}=4.5V\sim 6.0V, I_o=100mA$	$3.0mV=\pm 0.012\%$
Load Regulation	$V_{in}=5.0V, I_o=10mA\sim 100mA$	$0.022V=\pm 0.09\%$
Output Ripple	$V_{in}=5.0V, I_o=100mA$	500mVpp
Short Circuit Current	$V_{in}=5.0V, R_L=0.1\Omega$	910mA
Efficiency	$V_{in}=5.0V, I_o=100mA$	62.2%
Output Ripple With Optional Filter	$V_{in}=5.0V, I_o=100mA$	70mVpp

Application Information

Calculation	Step-Up	Step-Down	Voltage-Inverting
t_{on}/t_{off}	$\frac{V_{out} + V_F - V_{in(min)}}{V_{in(min)} - V_{sat}}$	$\frac{V_{out} + V_F}{V_{in(min)} - V_{sat} - V_{out}}$	$\frac{ V_{out} + V_F}{V_{in} - V_{sat}}$
$(t_{on} + t_{off})$	$\frac{1}{f}$	$\frac{1}{f}$	$\frac{1}{f}$
t_{off}	$\frac{t_{on} + t_{off}}{\frac{t_{on}}{t_{off}} + 1}$	$\frac{t_{on} + t_{off}}{\frac{t_{on}}{t_{off}} + 1}$	$\frac{t_{on} + t_{off}}{\frac{t_{on}}{t_{off}} + 1}$
t_{on}	$(t_{on} + t_{off}) - t_{off}$	$(t_{on} + t_{off}) - t_{off}$	$(t_{on} + t_{off}) - t_{off}$
C_T	$4.0 \times 10^{-5} t_{on}$	$4.0 \times 10^{-5} t_{on}$	$4.0 \times 10^{-5} t_{on}$
$I_{pk(switch)}$	$2I_{out(max)} \left(\frac{t_{on}}{t_{off}} + 1 \right)$	$2I_{out(max)}$	$2I_{out(max)} \left(\frac{t_{on}}{t_{off}} + 1 \right)$
R_{sc}	$0.3/I_{pk(switch)}$	$0.3/I_{pk(switch)}$	$0.3/I_{pk(switch)}$
$L_{(min)}$	$\left(\frac{V_{in(min)} - V_{sat}}{I_{pk(switch)}} \right) t_{on(max)}$	$\left(\frac{V_{in(min)} - V_{sat} - V_{out}}{I_{pk(switch)}} \right) t_{on(max)}$	$\left(\frac{V_{in(min)} - V_{sat}}{I_{pk(switch)}} \right) t_{on(max)}$
C_O	$9 \frac{I_{out} t_{on}}{V_{ripple(pp)}}$	$\frac{I_{pk(switch)} (t_{on} + t_{off})}{8V_{ripple(pp)}}$	$9 \frac{I_{out} t_{on}}{V_{ripple(pp)}}$

V_{sat} = Saturation voltage of the output switch

V_F = Forward voltage drop of the output rectifier

The following power supply characteristics must be chosen:

V_{in} — Nominal input voltage

V_{out} — Desired output voltage , $|V_{out}| = 1.25 \times (1 + R2 / R1)$

I_{out} — Desired output current

f_{min} — Minimum desired output switching frequency at the selected values of V_{in} and I_o

Vripple(pp) — Desired peak-to-peak output ripple voltage. In practice, the calculated capacitor value will need to be increased due to its equivalent series resistance and board layout. The ripple voltage should be kept to a low value since it will directly affect the line and load regulation.

Outline Dimensions

DIP8	Unit: mm
SOP8	Unit: mm

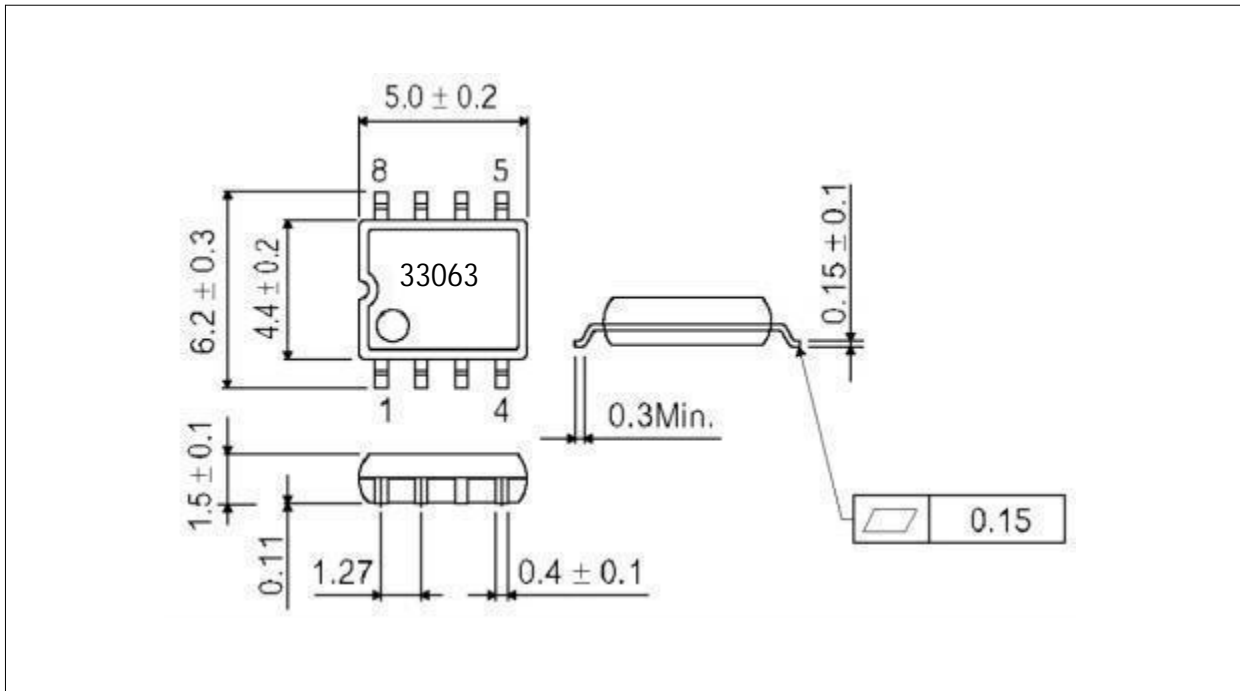

Statement:

- ◇ Shenzhen xinbole electronics co., ltd. reserves the right to change the product specifications, without notice! Before placing an order, the customer needs to confirm whether the information obtained is the latest version, and verify the integrity of the relevant information.
- ◇ Any semiconductor product is liable to fail or malfunction under certain conditions, and the buyer shall be responsible for complying with safety standards in the system design and whole machine manufacturing using Shenzhen xinbole electronics co., ltd products, and take appropriate security measures to avoid the potential risk of failure may result in personal injury or property losses of the situation occurred!
- ◇ Product performance is never ending, Shenzhen xinbole electronics co., ltd will be dedicated to provide customers with better performance, better quality of integrated circuit products.

单击下面可查看定价，库存，交付和生命周期等信息

[>>XBLW\(芯伯乐\)](#)