

Product Specification

XBLW LM258

Low Power Dual Operational Amplifier

WEB | www.xinboleic.com



Descriptions

The LM258 series consists of two independent, high gain, internally frequency compensated operational amplifiers which were designed specifically to operate from a single power supply over a wide range of voltages. Operation from split power supplies is also possible and the low power supply current drain is independent of the magnitude of the power supply voltage.

Application areas include transducer amplifiers, dc gain blocks and all the conventional op amp circuits which now can be more easily implemented in single power supply systems. For example, the LM258 series can be directly operated off of the standard +5V power supply voltage which is used in digital systems and will easily provide the required interface electronics without requiring the additional $\pm 15V$ power supplies.

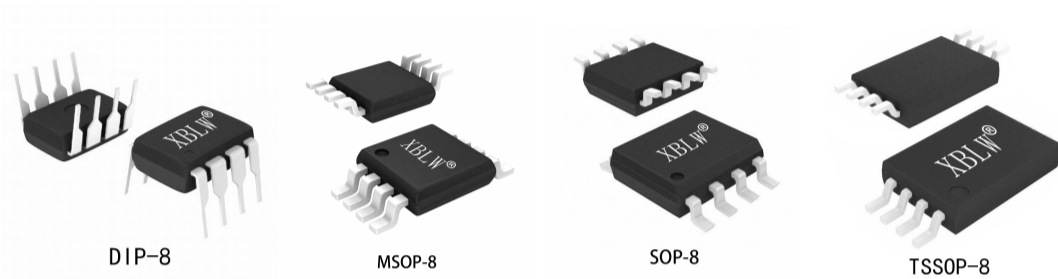

Feature

- Wide power supply range:
Single supply: 4V to 32V
or dual supplies: $\pm 2V$ to $\pm 16V$
- Very low supply current drain ($500 \mu A$)—essentially independent of supply voltage
- Wide bandwidth (unity gain): 1 MHz
- Low Input Bias Currents
- Common Mode Range Extends to Negative Supply

Applications

- Desktop PC and motherboard
- Electronic point-of-sale systems
- Indoor and outdoor air conditioners
- Merchant network and server power supply units
- Multi-function printers
- Power supplies and mobile chargers
- Uninterruptible power supplies
- Washers, dryers, and refrigerators
- AC inverters, string inverters, central inverters, and voltage frequency drives
- Motor control: AC induction, brushed DC, brushless DC, high-voltage, low-voltage, permanent magnet, and stepper motor

Ordering Information

Product Model	Package Type	Marking	Packing	Packing Qty
XBLW LM258N	DIP-8	LM258N	Tube	2000Pcs/Box
XBLW LM258DTR	SOP-8	LM258	Tape	2500Pcs/Reel
XBLW LM258MDTR	MSOP-8	258M	Tape	2500Pcs/Reel
XBLW LM258TDTR	TSSOP-8	LM258	Tape	2000Pcs/Reel

Pin Connections

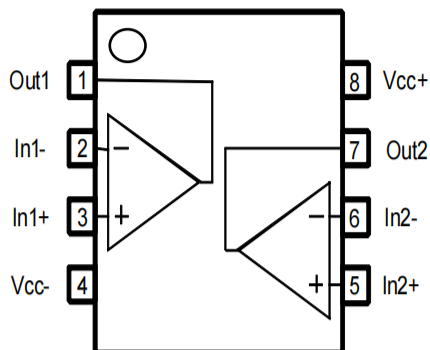

Schematic Diagram (One-Half of Circuit Shown)

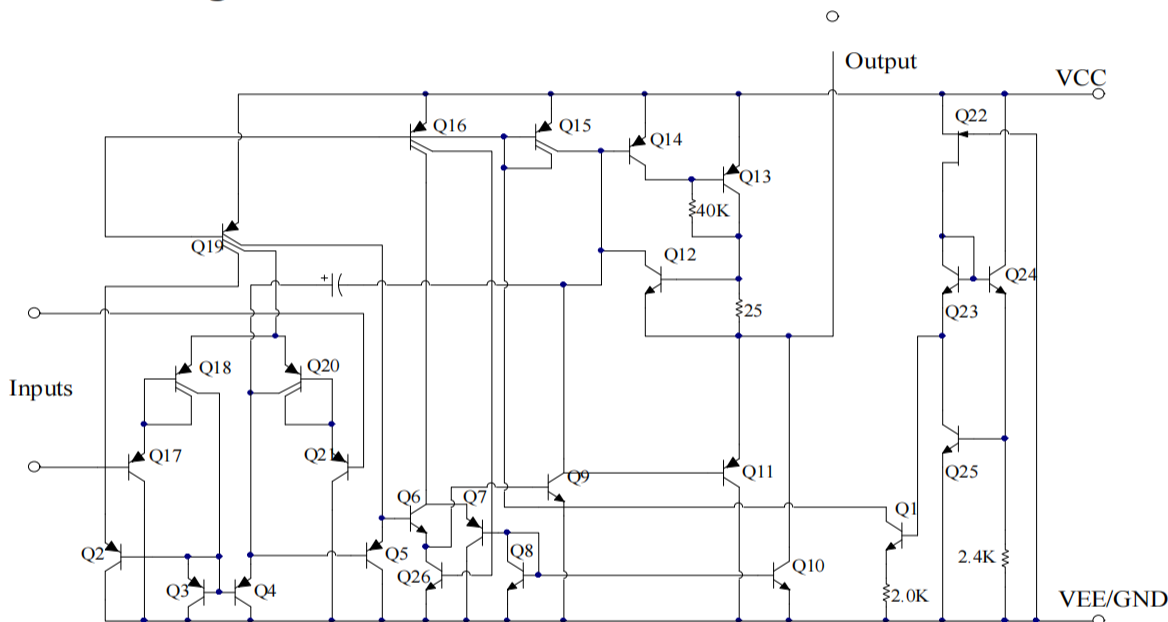

Absolute Maximum Ratings

TA = + 25 ° C, unless otherwise specified

Rating		Value	Unit
Power Supply Voltages		32 or ±16	V
Input Differential Voltage Range		32	V
Input Common Mode Voltage Range		-0.3 ~ VCC	V
Power Dissipation (Note1)	DIP8	830	mW
	SOP8	530	
Output Short Circuit Duration (One Amplifier) (V≤15V, Ta=25°C)		Continuous	
Input Current (VIN<-0.3V)		50	mA
Junction Temperature		150	°C
Operating Temperature Range		-20 ~ 85	°C
Storage Temperature Range		-65 ~ 150	°C

Electrical Characteristics

$V_{CC}=5.0V, T_A = +25^\circ C$, unless otherwise specified.

Parameter	Conditions	Min	Typ	Max	Units	
Input Offset Voltage	$T_A=25^\circ C, V_{CC} = 5.0 V \text{ to } 30 V, V_O = 1.4 V$		2	5	mV	
Input Bias Current	$T_A=25^\circ C, I_{IN}(+) \text{ or } I_{IN}(-), V_{CM}=0V$		45	250	nA	
Input Offset Current	$T_A=25^\circ C, I_{IN}(+) - I_{IN}(-), V_{CM}=0V$		3	50	nA	
Input Common Mode Voltage Range	$T_A=25^\circ C, V^+=30V$	0		$V_{CC} - 1.5$	V	
Power Supply Current	$R_L=\infty, \text{Total Device}$	$V_{CC} = 30V$		1	2	mA
		$V_{CC} = 5V$		0.5	1.2	mA
Large Signal Open Loop Voltage Gain	$V_{CC} = 15V, T_A=25^\circ C, R_L \geq 2k\Omega \text{ (for } V_O=1\sim 11V)$	25	100		V/mV	
Common Mode Rejection	DC, $T_A=25^\circ C, V_{CM}=0\sim V_{CC}-1.5V$	65	90		dB	
Power Supply Rejection	DC, $T_A=25^\circ C, V_{CC} = 5\sim 30V$	65	100		dB	
Output Source Current	$V_{IN}(+)=1V, V_{IN}(-)=0V, V_{CC}=15V, V_O=2V, T_A=25^\circ C$	20	40		mA	
Output Sink Current	$V_{IN}(-)=1V, V_{IN}(+)=0V, V_{CC}=15V, V_O=2V, T_A=25^\circ C$	10	15		mA	
	$V_{IN}(-)=1V, V_{IN}(+)=0V, V_{CC}=15V, V_O=200mV, T_A=25^\circ C$	12	50		μA	
Output Short Circuit to Ground	$V_{CC}=15V, T_A=25^\circ C$		40	60	mA	
Output Voltage Swing	VOH	$V_{CC}=30V, R_L=2k\Omega$	26			V
		$V_{CC}=30V, R_L=10k\Omega$	27	28		V
	VOL	$V_{CC}=5V, R_L=10k\Omega$		5	20	mV

Typical Applications

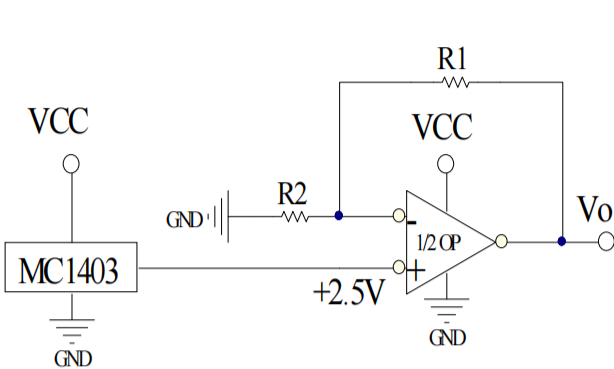

Voltage Reference, $V_o = 2.5V (1 + R1/R2)$

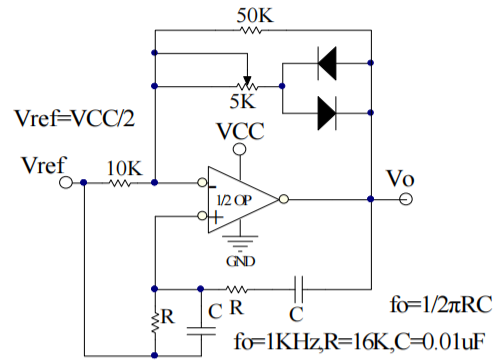

Wien Bridge Oscillator

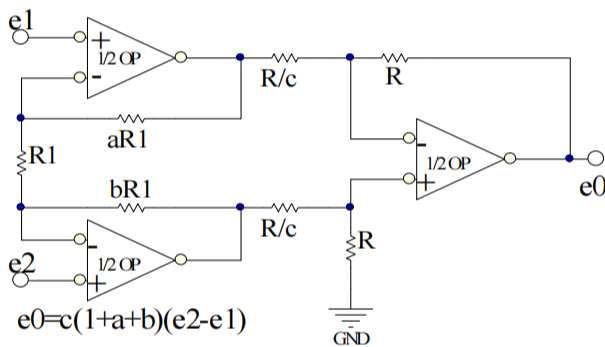

High Impedance Differential Amplifier

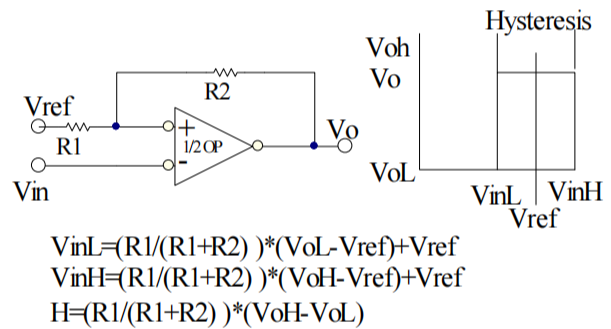

$$V_{inL} = (R1/(R1+R2)) * (VoL - Vref) + Vref$$

$$V_{inH} = (R1/(R1+R2)) * (VoH - Vref) + Vref$$

$$H = (R1/(R1+R2)) * (VoH - VoL)$$

Comparator with Hysteresis

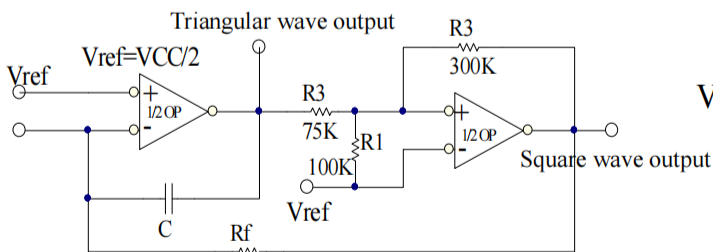

Function Generator

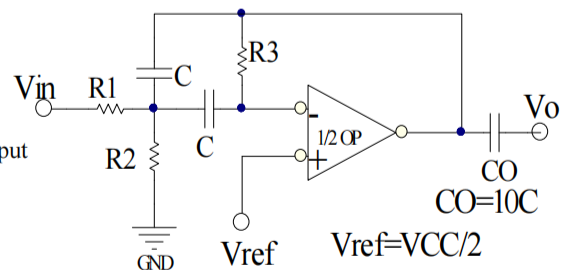

f_o = center frequency

Multiple Feedback Bandpass Filter

Typical Performance Characteristics

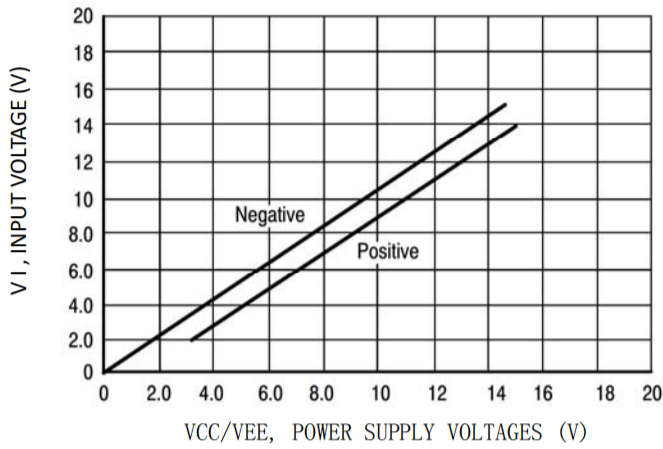

Input Voltage Range

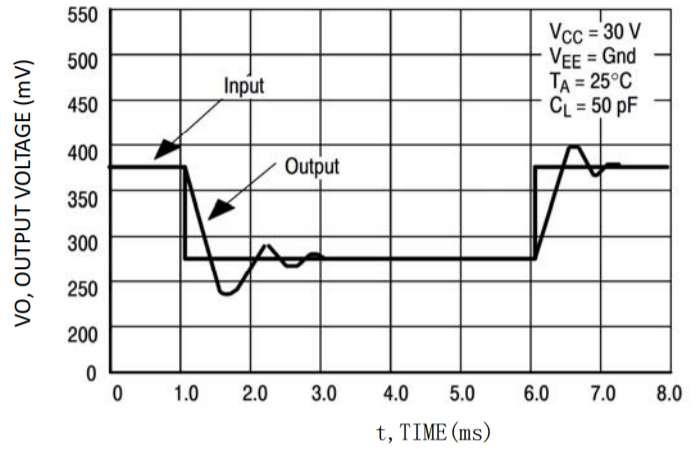

Small Signal Voltage Follower Pulse Response
(Noninverting)

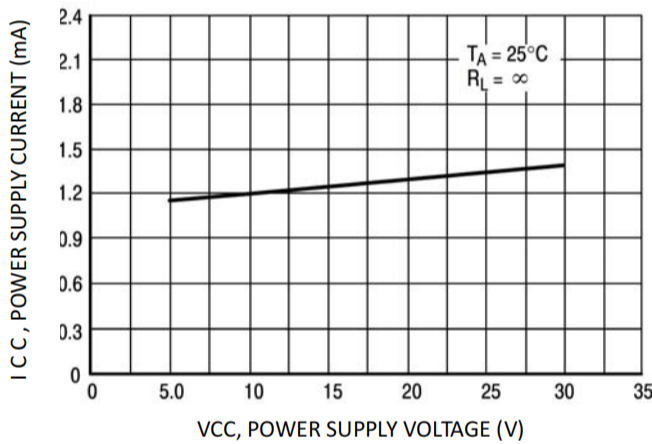

Power Supply Current versus Power Supply Voltage

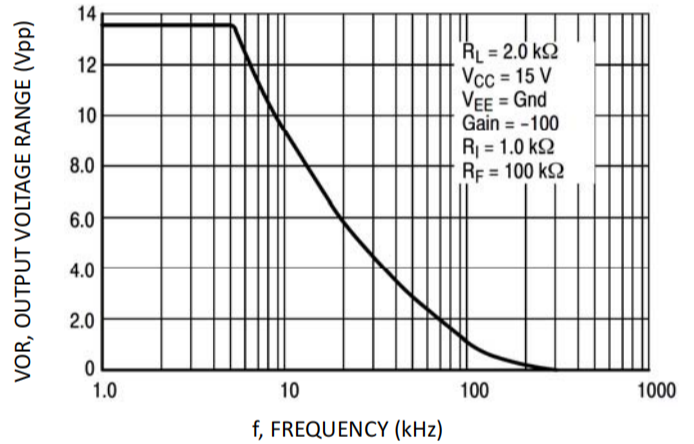

Large-Signal Frequency Response

Package Information

- DIP-8

Symbol	Size	Dimensions In Millimeters		Symbol	Size	Dimensions In Inches	
		Min(mm)	Max(mm)			Min(in)	Max(in)
A		3.710	4.310	A		0.146	0.170
A1		0.510		A1		0.020	
A2		3.200	3.600	A2		0.126	0.142
B		0.380	0.570	B		0.015	0.022
B1		1.524 (BSC)		B1		0.060 (BSC)	
C		0.204	0.360	C		0.008	0.014
D		9.000	9.400	D		0.354	0.370
E		6.200	6.600	E		0.244	0.260
E1		7.320	7.920	E1		0.288	0.312
e		2.540 (BSC)		e		0.100 (BSC)	
L		3.000	3.600	L		0.118	0.142
E2		8.400	9.000	E2		0.331	0.354

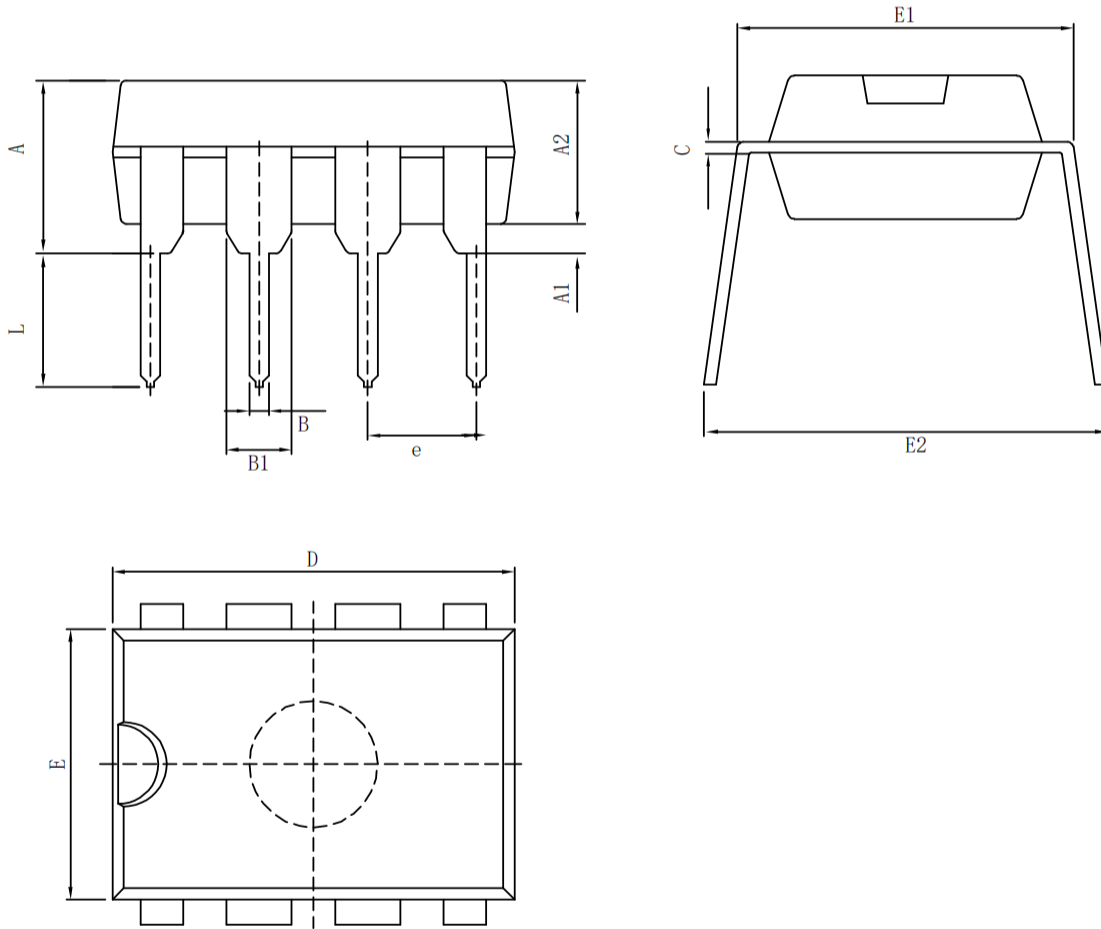

· MSOP-8

Size Symbol	Dimensions In Millimeters		Size Symbol	Dimensions In Inches	
	Min (mm)	Max (mm)		Min (in)	Max (in)
A	0.820	1.100	A	0.320	0.043
A1	0.020	0.150	A1	0.001	0.006
A2	0.750	0.950	A2	0.030	0.037
b	0.250	0.380	b	0.010	0.015
c	0.090	0.230	c	0.004	0.009
D	2.900	3.100	D	0.114	0.122
e	0.65 (BSC)		e	0.026 (BSC)	
E	2.900	3.100	E	0.114	0.122
E1	4.750	5.050	E1	0.187	0.199
L	0.400	0.800	L	0.016	0.031
θ	0°	6°	θ	0°	6°

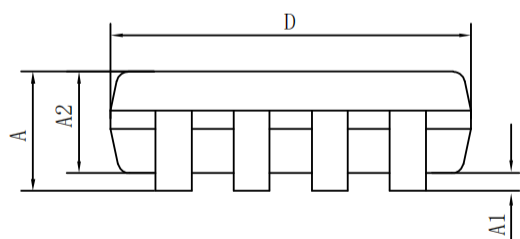
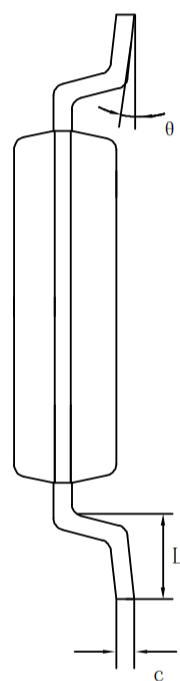
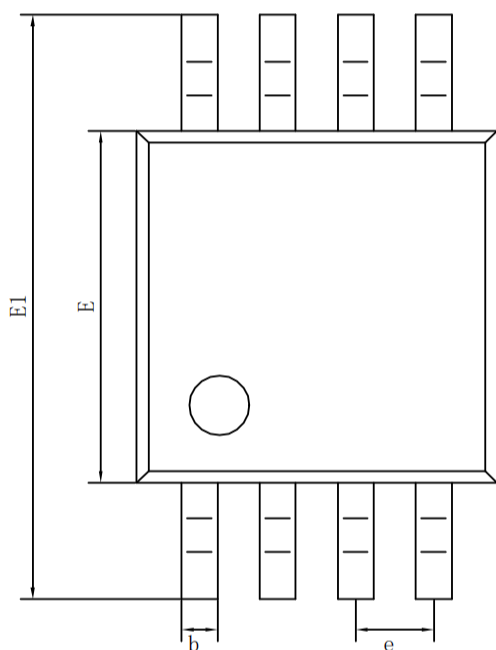

• SOP-8

Symbol	Dimensions In Millimeters		Symbol	Dimensions In Inches	
	Min (mm)	Max (mm)		Min (in)	Max (in)
A	1.350	1.750	A	0.053	0.069
A1	0.100	0.250	A1	0.004	0.010
A2	1.350	1.550	A2	0.053	0.061
b	0.330	0.510	b	0.013	0.020
c	0.170	0.250	c	0.006	0.010
D	4.700	5.100	D	0.185	0.200
E	3.800	4.000	E	0.150	0.157
E1	5.800	6.200	E1	0.228	0.224
e	1.270 (BSC)		e	0.050 (BSC)	
L	0.400	1.270	L	0.016	0.050
θ	0°	8°	θ	0°	8°

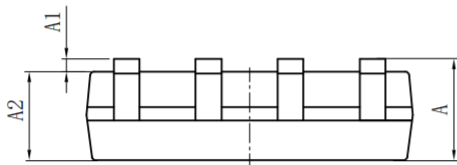
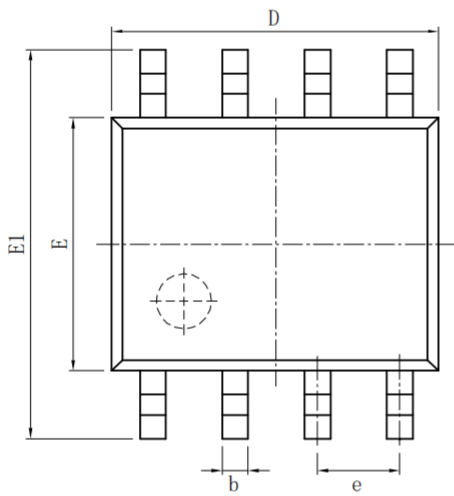

· TSSOP-8

Size Symbol	Dimensions In Millimeters		Size Symbol	Dimensions In Inches	
	Min (mm)	Max (mm)		Min (in)	Max (in)
D	2.900	3.100	D	0.114	0.122
E	4.300	4.500	E	0.169	0.177
b	0.190	0.300	b	0.007	0.012
c	0.090	0.200	c	0.004	0.008
E1	6.250	6.550	E1	0.246	0.258
A		1.100	A		0.043
A2	0.800	1.000	A2	0.031	0.039
A1	0.020	0.150	A1	0.001	0.006
e	0.65 (BSC)		e	0.026 (BSC)	
L	0.500	0.700	L	0.020	0.028
H	0.25 (TYP)		H	0.01 (TYP)	
θ	1°	7°	θ	1°	7°

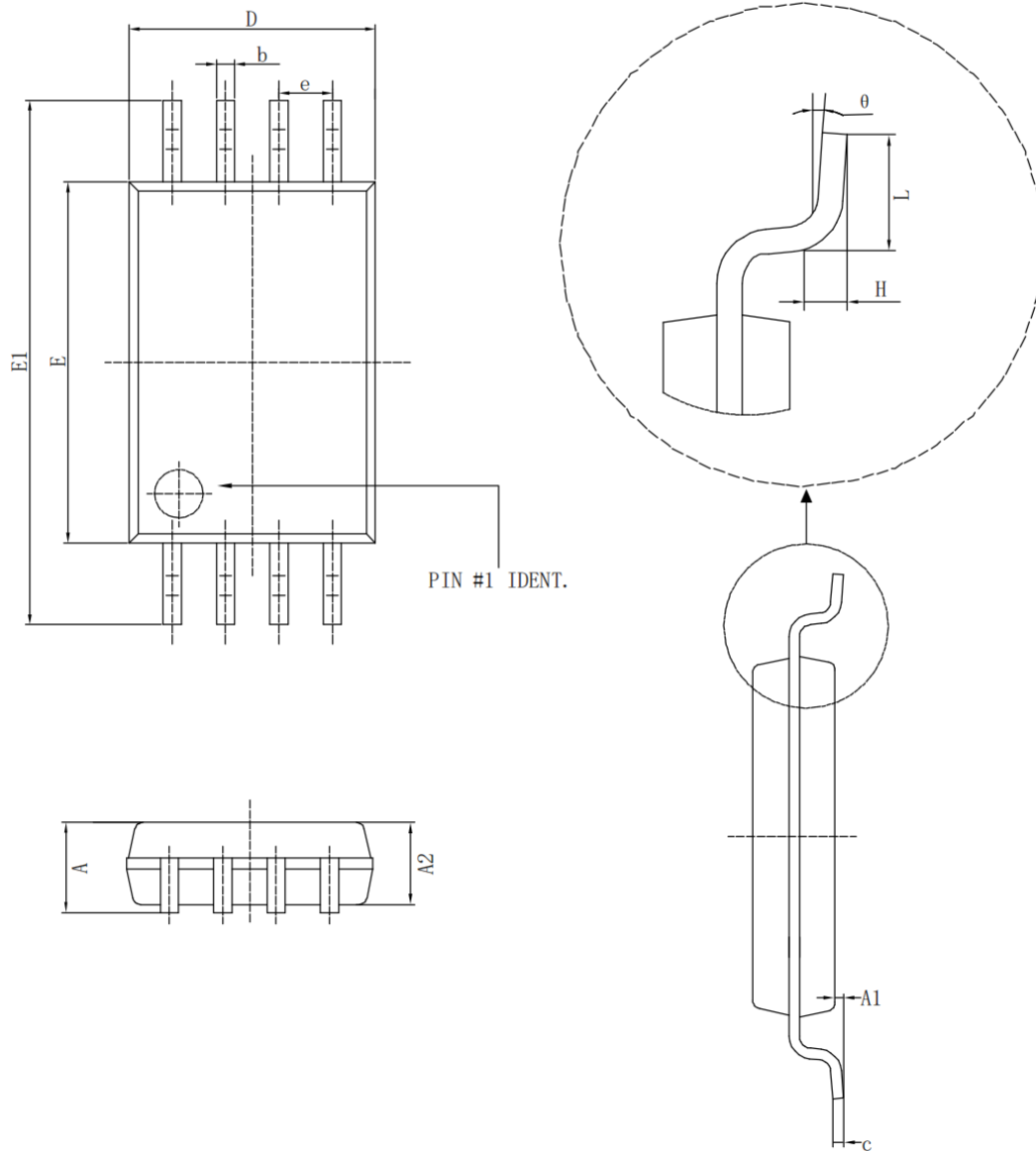

Statement:

- XBLW reserves the right to modify the product manual without prior notice! Before placing an order, customers need to confirm whether the obtained information is the latest version and verify the completeness of the relevant information.
- Any semi-guide product is subject to failure or malfunction under specified conditions. It is the buyer's responsibility to comply with safety standards when using XBLW products for system design and whole machine manufacturing. And take the appropriate safety measures to avoid the potential in the risk of loss of personal injury or loss of property situation!
- XBLW products have not been licensed for life support, military, and aerospace applications, and therefore XBLW is not responsible for any consequences arising from the use of this product in these areas.
- If any or all XBLW products (including technical data, services) described or contained in this document are subject to any applicable local export control laws and regulations, they may not be exported without an export license from the relevant authorities in accordance with such laws.
- The specifications of any and all XBLW products described or contained in this document specify the performance, characteristics, and functionality of said products in their standalone state, but do not guarantee the performance, characteristics, and functionality of said products installed in Customer's products or equipment. In order to verify symptoms and conditions that cannot be evaluated in a standalone device, the Customer should ultimately evaluate and test the device installed in the Customer's product device.
- XBLW documentation is only allowed to be copied without any alteration of the content and with the relevant authorization. XBLW assumes no responsibility or liability for altered documents.
- XBLW is committed to becoming the preferred semiconductor brand for customers, and XBLW will strive to provide customers with better performance and better quality products.