

General Description

The SN74HC/HCT14 is a hex inverter with Schmitt-trigger inputs. This device features reduced input threshold levels to allow interfacing to TTL logic levels. Inputs include clamp diodes. This enables the use of current limiting resistors to interface inputs to voltages in excess of V_{CC} . Schmitt trigger inputs transform slowly changing input signals into sharply defined jitter-free output signals.

Features

- Input levels:
For SN74HC14: CMOS level
For SN74HCT14: TTL level
- Low-power dissipation
- Specified from -40°C to $+125^{\circ}\text{C}$
- Packaging information: DIP14/SOP14/TSSOP14

ORDERING INFORMATION

DEVICE	Package Type	MARKING	Packing	Packing QTY
SN74HC14N	DIP-14	74HC14N	Tube	1000/Box
SN74HC14DTR	SOP-14	74HC14	Tape	2500/Reel
SN74HC14TDTR	TSSOP-14	74HC14	Tape	3000/Reel
SN74HCT14N	DIP-14	74HCT14N	Tube	1000/Box
SN74HCT14DTR	SOP-14	74HCT14	Tape	2500/Reel
SN74HCT14TDTR	TSSOP-14	74HCT14	Tape	3000/Reel

Block Diagram And Pin Description

Block Diagram

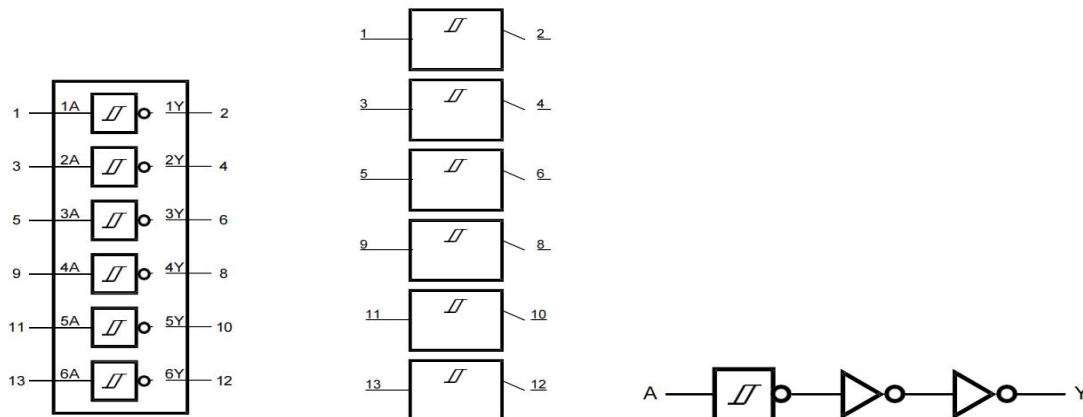
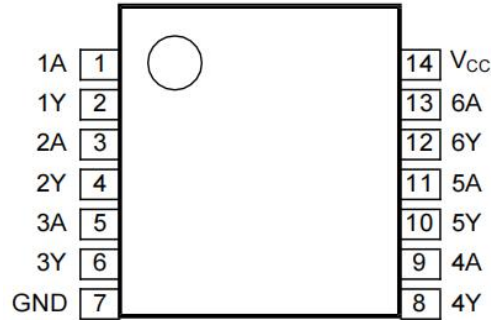

Figure 1. Logic symbol

Figure 2. IEC logic symbol

Figure 3. Logic diagram for one gate

Pin Configurations



Pin Description

Pin No.	Pin Name	Description
1	1A	data input
2	1Y	data output
3	2A	data input
4	2Y	data output
5	3A	data input
6	3Y	data output
7	GND	ground (0V)
8	4Y	data output
9	4A	data input
10	5Y	data output
11	5A	data input
12	6Y	data output
13	6A	data input
14	V _{CC}	supply voltage

Function Table

Input	Output
nA	nY
L	H
H	L

Note: H=HIGH voltage level; L=LOW voltage level.

Electrical Parameter

Absolute Maximum Ratings (Voltages are referenced to GND (ground=0V), unless otherwise specified.)

Parameter	Symbol	Conditions	Min.	Max.	Unit
supply voltage	V_{CC}		-0.5	+7	V
input clamping current	I_{IK}	$V_I < -0.5V$ or $V_I > V_{CC} + 0.5V$	-	± 20	mA
output clamping current	I_{OK}	$V_O < -0.5V$ or $V_O > V_{CC} + 0.5V$	-	± 20	mA
output current	I_O	$-0.5V < V_O < V_{CC} + 0.5V$	-	± 25	mA
supply current	I_{CC}	-	-	50	mA
ground current	I_{GND}	-	-50	-	mA
total power dissipation	P_{tot}	-	-	500	mW
storage temperature	T_{stg}	-	-65	+150	°C
soldering temperature	T_L	10s	DIP	245	°C
			SOP	250	

Recommended Operating Conditions

Parameter	Symbol	Conditions	Min.	Typ.	Max.	Unit
SN74HC14						
supply voltage	V_{CC}	-	2.0	5.0	6.0	V
input voltage	V_I	-	0	-	V_{CC}	V
output voltage	V_O	-	0	-	I_{CC}	V
ambient temperature	T_{amb}	-	-40	-	+125	°C
SN74HCT14						
supply voltage	V_{CC}	-	4.5	5.0	5.5	V
input voltage	V_I	-	0	-	V_{CC}	V
output voltage	V_O	-	0	-	V_{CC}	V
ambient temperature	T_{amb}	-	-40	-	+125	°C

Electrical Characteristics

DC Characteristics 1 (Tamb=25°C, voltages are referenced to GND (ground=0V), unless otherwise specified.)

Parameter	Symbol	Conditions	Min.	Typ.	Max.	Unit	
SN74HC14							
HIGH-level output voltage	V _{OH}	V _i =V _{T+} or V _{T-}	I _O =-20uA; V _{CC} =2.0V	1.9	2.0	-	V
			I _O =-20uA; V _{CC} =4.5V	4.4	4.5	-	V
			I _O =-20uA; V _{CC} =6.0V	5.9	6.0	-	V
			I _O =-4.0mA; V _{CC} =4.5V	3.98	4.32	-	V
			I _O =-5.2mA; V _{CC} =6.0V	5.48	5.81	-	V
LOW-level output voltage	V _{OL}	V _i =V _{T+} or V _{T-}	I _O =20uA; V _{CC} =2.0V	-	0	0.1	V
			I _O =20uA; V _{CC} =4.5V	-	0	0.1	V
			I _O =20uA; V _{CC} =6.0V	-	0	0.1	V
			I _O =4.0mA; V _{CC} =4.5V	-	0.15	0.26	V
			I _O =5.2mA; V _{CC} =6.0V	-	0.16	0.26	V
input leakage current	I _I	V _i =V _{CC} or GND; V _{CC} =6.0V	-	-	±1	μA	
supply current	I _{CC}	V _i =V _{CC} or GND; I _O =0A; V _{CC} =6.0V	-	-	2.0	μA	
input capacitance	C _I		-	3.5	-	pF	
SN74HCT14							
HIGH-level output voltage	V _{OH}	V _i =V _{T+} or V _{T-}	I _O =-20uA; V _{CC} =4.5V	4.4	4.5	-	V
			I _O =-4.0mA; V _{CC} =4.5V	3.98	4.32	-	V
LOW-level output voltage	V _{OL}	V _i =V _{T+} or V _{T-}	I _O =20uA; V _{CC} =4.5V	-	0	0.1	V
			I _O =4.0mA; V _{CC} =4.5V	-	0.15	0.26	V
input leakage current	I _I	V _i =V _{CC} or GND; V _{CC} =5.5V	-	-	±1	μA	
supply current	I _{CC}	V _i =V _{CC} or GND; I _O =0A; V _{CC} =5.5V	-	-	2.0	μA	
additional supply current	ΔI _{CC}	per input pin; V _i =V _{CC} -2.1V; I _O =0A; other inputs at V _{CC} or GND; V _{CC} =4.5V to 5.5V	-	30	108	μA	
input capacitance	C _I		-	3.5	-	pF	

DC Characteristics 2

(Tamb=-40°C to +85°C, voltages are referenced to GND (ground=0V), unless otherwise specified.)

Parameter	Symbol	Conditions	Min.	Typ.	Max.	Unit	
SN74HC14							
HIGH-level output voltage	V _{OH}	V _i =V _{T+} or V _{T-}	I _O =-20μA; V _{CC} =2.0V	1.9	-	-	V
			I _O =-20μA; V _{CC} =4.5V	4.4	-	-	V
			I _O =-20μA; V _{CC} =6.0V	5.9	-	-	V
			I _O =-4.0mA; V _{CC} =4.5V	3.84	-	-	V
			I _O =-5.2mA; V _{CC} =6.0V	5.34	-	-	V
LOW-level output voltage	V _{OL}	V _i =V _{T+} or V _{T-}	I _O =20μA; V _{CC} =2.0V	-	-	0.1	V
			I _O =20μA; V _{CC} =4.5V	-	-	0.1	V
			I _O =20μA; V _{CC} =6.0V	-	-	0.1	V
			I _O =4.0mA; V _{CC} =4.5V	-	-	0.33	V
			I _O =5.2mA; V _{CC} =6.0V	-	-	0.33	V
input leakage current	I _I	V _i = V _{CC} or GND; V _{CC} =6.0V	-	-	±1	μA	
supply current	I _{CC}	V _i =V _{CC} or GND; I _O =0A; V _{CC} =6.0V	-	-	20	μA	
SN74HCT14							
HIGH-level output voltage	V _{OH}	V _i =V _{T+} or V _{T-}	I _O =-20μA; V _{CC} =4.5V	4.4	-	-	V
			I _O =-4.0mA; V _{CC} =4.5V	3.84	-	-	V
LOW-level output voltage	V _{OL}	V _i =V _{T+} or V _{T-}	I _O =20μA; V _{CC} =4.5V	-	-	0.1	V
			I _O =4.0mA; V _{CC} =4.5V	-	-	0.33	V
input leakage current	I _I	V _i = V _{CC} or GND; V _{CC} =5.5V	-	-	±1	μA	
supply current	I _{CC}	V _i =V _{CC} or GND; I _O =0A; V _{CC} =5.5V	-	-	20	μA	
additional supply current	ΔI _{CC}	per input pin; V _i =V _{CC} -2.1V; I _O =0A; other inputs at V _{CC} or GND; V _{CC} =4.5V to 5.5V	-	-	135	μA	

DC Characteristics 3

(Tamb=-40°C to +125°C, voltages are referenced to GND (ground=0V), unless otherwise specified.)

Parameter	Symbol	Conditions	Min.	Typ.	Max.	Unit	
SN74HC14							
HIGH-level output voltage	V _{OH}	V _i =V _{T+} or V _{T-}	I _O =-20μA; V _{CC} =2.0V	1.9	-	-	V
			I _O =-20μA; V _{CC} =4.5V	4.4	-	-	V
			I _O =-20μA; V _{CC} =6.0V	5.9	-	-	V
			I _O =-4.0mA; V _{CC} =4.5V	3.7	-	-	V
			I _O =-5.2mA; V _{CC} =6.0V	5.2	-	-	V
LOW-level output voltage	V _{OL}	V _i =V _{T+} or V _{T-}	I _O =20μA; V _{CC} =2.0V	-	-	0.1	V
			I _O =20μA; V _{CC} =4.5V	-	-	0.1	V
			I _O =20μA; V _{CC} =6.0V	-	-	0.1	V
			I _O =4.0mA; V _{CC} =4.5V	-	-	0.4	V
			I _O =5.2mA; V _{CC} =6.0V	-	-	0.4	V
input leakage current	I _I	V _i = V _{CC} or GND; V _{CC} =6.0V	-	-	±1	μA	
supply current	I _{CC}	V _i =V _{CC} or GND; I _O =0A; V _{CC} =6.0V	-	-	40	μA	
SN74HCT14							
HIGH-level output voltage	V _{OH}	V _i =V _{T+} or V _{T-}	I _O =-20μA; V _{CC} =4.5V	4.4	-	-	V
			I _O =-4.0mA; V _{CC} =4.5V	3.7	-	-	V
LOW-level output voltage	V _{OL}	V _i =V _{T+} or V _{T-}	I _O =20μA; V _{CC} =4.5V	-	-	0.1	V
			I _O =4.0mA; V _{CC} =4.5V	-	-	0.4	V
input leakage current	I _I	V _i = V _{CC} or GND; V _{CC} =5.5V	-	-	±1	μA	
supply current	I _{CC}	V _i =V _{CC} or GND; I _O =0A; V _{CC} =5.5V	-	-	40	μA	
additional supply current	ΔI _{CC}	per input pin; V _i =V _{CC} -2.1V; I _O =0A; other inputs at V _{CC} or GND; V _{CC} =4.5V to 5.5V	-	-	147	μA	

AC Characteristics 1 (Tamb=25°C, voltages are referenced to GND (ground=0V), unless otherwise specified.)

Parameter	Symbol	Conditions	Min.	Typ.	Max.	Unit	
SN74HC14							
nA,nB to nY Propagation delay	t _{PLH} ,t _{PHL}	see Figure5	V _{CC} =2.0V	-	41	125	ns
			V _{CC} =4.5V	-	15	25	ns
			V _{CC} =5.0V;CL=15pF	-	12	-	ns
			V _{CC} =6.0V	-	12	21	ns
transition time	t _{THL} ,t _{TLH}	see Figure5	V _{CC} =2.0V	-	19	75	ns
			V _{CC} =4.5V	-	7	15	ns
			V _{CC} =6.0V	-	6	13	ns
SN74HCT14							
nA,nB to nY Propagation delay	t _{PLH} ,t _{PHL}	see Figure5	V _{CC} =4.5V	-	20	34	ns
			V _{CC} =5.0V;CL=15pF	-	17	-	ns
transition time	t _{THL} ,t _{TLH}	see Figure5	V _{CC} =4.5V	-	7	15	ns

AC Characteristics 2

(Tamb=-40°C to +85°C, voltages are referenced to GND (ground=0V), unless otherwise specified.)

Parameter	Symbol	Conditions	Min.	Typ.	Max.	Unit	
SN74HC14							
nA,nB to nY Propagation delay	t _{PLH} ,t _{PHL}	see Figure5	V _{CC} =2.0V	-	-	155	ns
			V _{CC} =4.5V	-	-	31	ns
			V _{CC} =6.0V	-	-	26	ns
transition time	t _{THL} ,t _{TLH}	see Figure5	V _{CC} =2.0V	-	-	95	ns
			V _{CC} =4.5V	-	-	19	ns
			V _{CC} =6.0V	-	-	15	ns
SN74HCT14							
nA,nB to nY Propagation delay	t _{PLH} ,t _{PHL}	see Figure5	V _{CC} =4.5V	-	-	43	ns
transition time	t _{THL} ,t _{TLH}	see Figure5	V _{CC} =4.5V	-	-	19	ns

AC Characteristics 3

(Tamb=-40°C to +125°C, voltages are referenced to GND (ground=0V), unless otherwise specified.)

Parameter	Symbol	Conditions	Min.	Typ.	Max.	Unit	
SN74HC14							
nA,nB to nY Propagation delay	t _{PLH} ,t _{PHL}	see Figure5	V _{CC} =2.0V	-	-	190	ns
			V _{CC} =4.5V	-	-	38	ns
			V _{CC} =6.0V	-	-	32	ns
transition time	t _{THL} ,t _{TLH}	see Figure5	V _{CC} =2.0V	-	-	110	ns
			V _{CC} =4.5V	-	-	22	ns
			V _{CC} =6.0V	-	-	19	ns
SN74HCT14							
nA,nB to nY Propagation delay	t _{PLH} ,t _{PHL}	see Figure5	V _{CC} =4.5V	-	-	51	ns
transition time	t _{THL} ,t _{TLH}	see Figure5	V _{CC} =4.5V	-	-	22	ns

Transfer Characteristics 1(Tamb=25°C, voltages are referenced to GND (ground=0V), unless otherwise specified.)

Parameter	Symbol	Conditions	Min.	Typ.	Max.	Unit
SN74HC14						
positive-going threshold voltage	V _{T+}	V _{CC} =2.0V	0.7	1.18	1.5	V
		V _{CC} =4.5V	1.7	2.38	3.15	V
		V _{CC} =6.0V	2.1	3.14	4.2	V
negative-going threshold voltage	V _{T-}	V _{CC} =2.0V	0.3	0.52	0.9	V
		V _{CC} =4.5V	0.9	1.4	2.0	V
		V _{CC} =6.0V	1.2	1.89	2.6	V
hysteresis voltage	V _H	V _{CC} =2.0V	-	0.66	-	V
		V _{CC} =4.5V	-	0.98	-	V
		V _{CC} =6.0V	-	1.25	-	V
SN74HCT14						
positive-going threshold voltage	V _{T+}	V _{CC} =4.5V	1.2	1.41	1.9	V
		V _{CC} =5.5V	1.4	1.59	2.1	V
negative-going threshold voltage	V _{T-}	V _{CC} =4.5V	0.5	0.85	1.2	V
		V _{CC} =5.5V	0.6	0.99	1.4	V
hysteresis voltage	V _H	V _{CC} =4.5V	-	0.56	-	V
		V _{CC} =5.5V	-	0.6	-	V

Transfer Characteristics 2

(Tamb=-40°C to +85°C, voltages are referenced to GND (ground=0V), unless otherwise specified.)

Parameter	Symbol	Conditions	Min.	Typ.	Max.	Unit
SN74HC14						
positive-going threshold voltage	V _{T+}	V _{CC} =2.0V	0.7	-	1.5	V
		V _{CC} =4.5V	1.7	-	3.15	V
		V _{CC} =6.0V	2.1	-	4.2	V
negative-going threshold voltage	V _{T-}	V _{CC} =2.0V	0.3	-	0.9	V
		V _{CC} =4.5V	0.9	-	2.0	V
		V _{CC} =6.0V	1.2	-	2.6	V
hysteresis voltage	V _H	V _{CC} =2.0V	-	0.66	-	V
		V _{CC} =4.5V	-	0.98	-	V
		V _{CC} =6.0V	-	1.25	-	V
SN74HCT14						
positive-going threshold voltage	V _{T+}	V _{CC} =4.5V	1.2	-	1.9	V
		V _{CC} =5.5V	1.4	-	2.1	V
negative-going threshold voltage	V _{T-}	V _{CC} =4.5V	0.5	-	1.2	V
		V _{CC} =5.5V	0.6	-	1.4	V
hysteresis voltage	V _H	V _{CC} =4.5V	-	0.56	-	V
		V _{CC} =5.5V	-	0.6	-	V

Transfer Characteristics 3

(Tamb=-40°C to +125°C, voltages are referenced to GND (ground=0V), unless otherwise specified.)

Parameter	Symbol	Conditions	Min.	Typ.	Max.	Unit
SN74HC14						
positive-going threshold voltage	V _{T+}	V _{CC} =2.0V	0.7	-	1.5	V
		V _{CC} =4.5V	1.7	-	3.15	V
		V _{CC} =6.0V	2.1	-	4.2	V
negative-going threshold voltage	V _{T-}	V _{CC} =2.0V	0.3	-	0.9	V
		V _{CC} =4.5V	0.9	-	2.0	V
		V _{CC} =6.0V	1.2	-	2.6	V
hysteresis voltage	V _H	V _{CC} =2.0V	-	0.66	-	V
		V _{CC} =4.5V	-	0.98	-	V
		V _{CC} =6.0V	-	1.25	-	V
SN74HCT14						
positive-going threshold voltage	V _{T+}	V _{CC} =4.5V	1.2	-	1.9	V
		V _{CC} =5.5V	1.4	-	2.1	V
negative-going threshold voltage	V _{T-}	V _{CC} =4.5V	0.5	-	1.2	V
		V _{CC} =5.5V	0.6	-	1.4	V
hysteresis voltage	V _H	V _{CC} =4.5V	-	0.56	-	V
		V _{CC} =5.5V	-	0.6	-	V

Testing Circuit

AC Testing Circuit

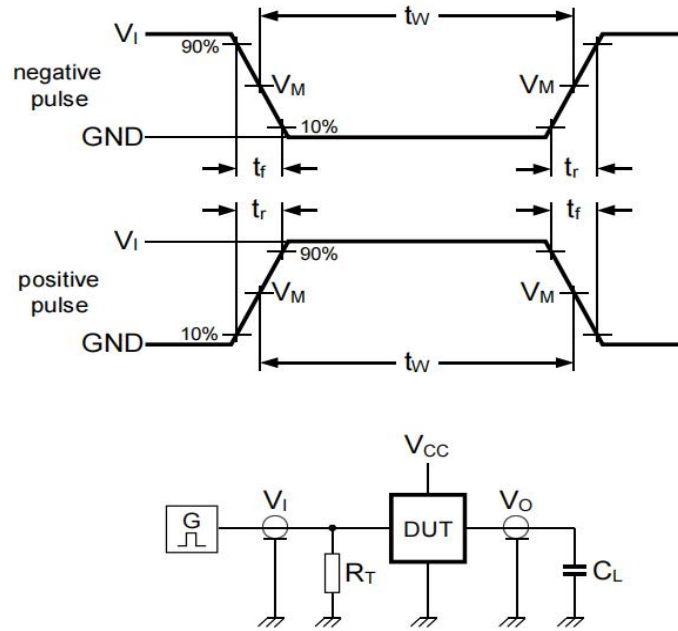

Figure 4. Test circuit for measuring switching times

Definitions for test circuit:

C_L =load capacitance including jig and probe capacitance.

R_T =termination resistance should be equal to the output impedance Z_o of the pulse generator.

AC Testing Waveforms

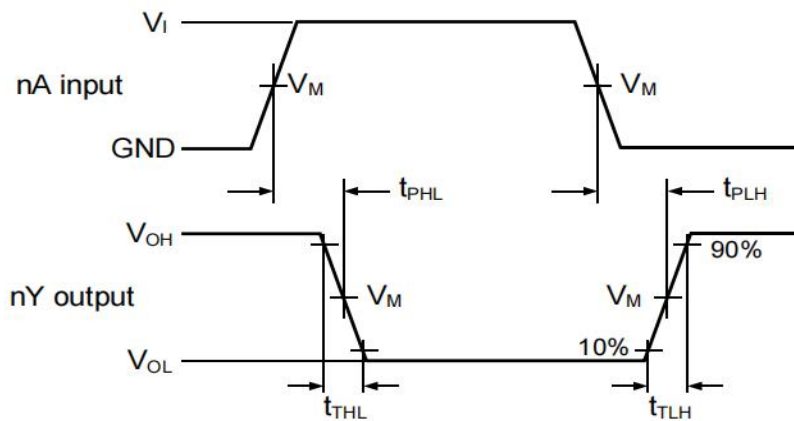

Figure 5. Input to output propagation delays

Transfer Characteristics Waveform

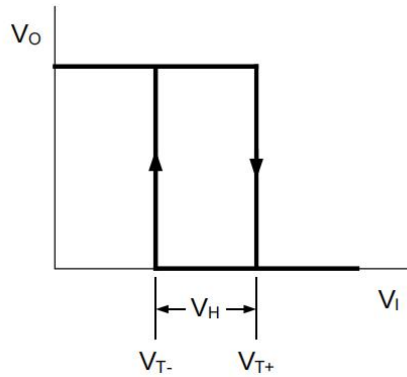

Figure 6. Transfer characteristics

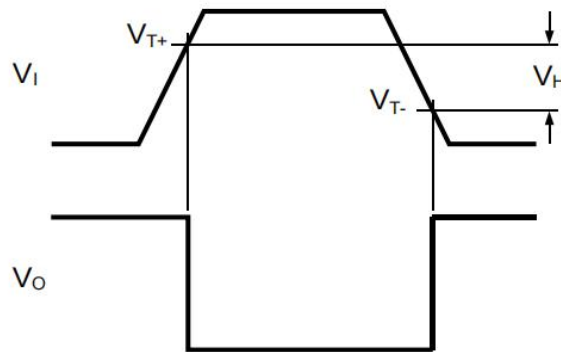

Figure 7. Transfer characteristics definitions

Measurement Points

Type	Input	Output		
	V_M	V_M	V_X	V_Y
SN74HC14	$0.5 \times V_{CC}$	$0.5 \times V_{CC}$	$0.1 \times V_{CC}$	$0.9 \times V_{CC}$
SN74HCT14	1.3V	1.3V	$0.1 \times V_{CC}$	$0.9 \times V_{CC}$

Test Data

Type	Input		Load	Test
	V_I	t_r, t_f	C_L	
SN74HC14	V_{CC}	6.0ns	15pF, 50pF	t_{PLH}, t_{PHL}
SN74HCT14	3.0V	6.0ns	15pF, 50pF	t_{PLH}, t_{PHL}

Package Information

DIP14

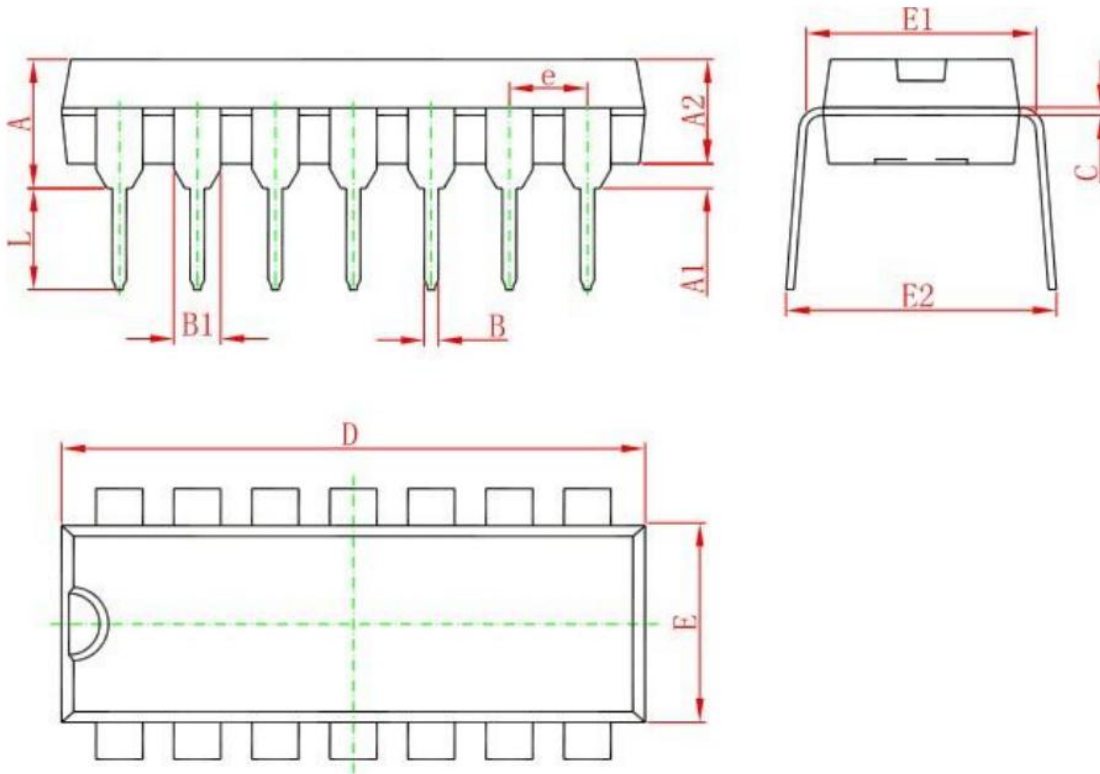

Symbol	Dimensions In Millimeters		Dimensions In Inches	
	Min	Max	Min	Max
A	3.710	4.310	0.146	0.170
A1	0.510		0.020	
A2	3.200	3.600	0.126	0.142
B	0.380	0.570	0.015	0.022
B1	1.524(BSC)		0.060(BSC)	
C	0.204	0.360	0.008	0.014
D	18.800	19.200	0.740	0.756
E	6.200	6.600	0.244	0.260
E1	7.320	7.920	0.288	0.312
e	2.540(BSC)		0.100(BSC)	
L	3.000	3.600	0.118	0.142
E2	8.400	9.000	0.331	0.354

SOP14

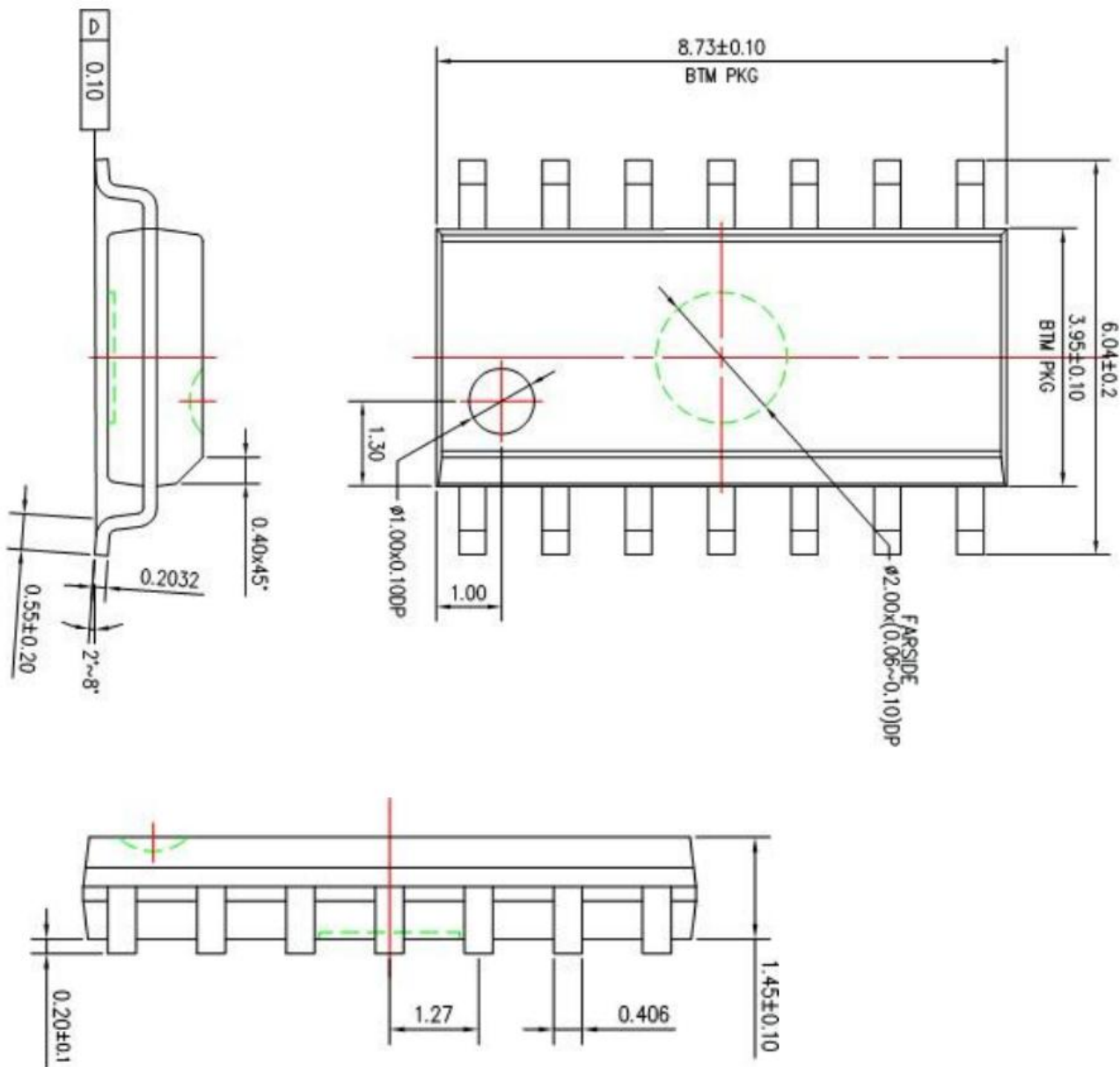

TSSOP14

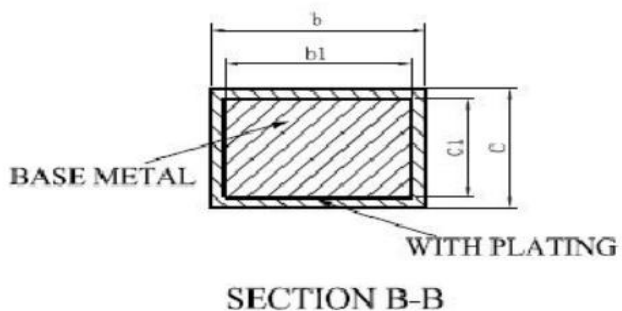
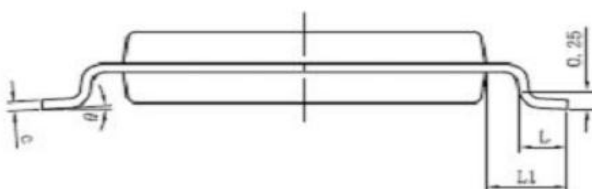
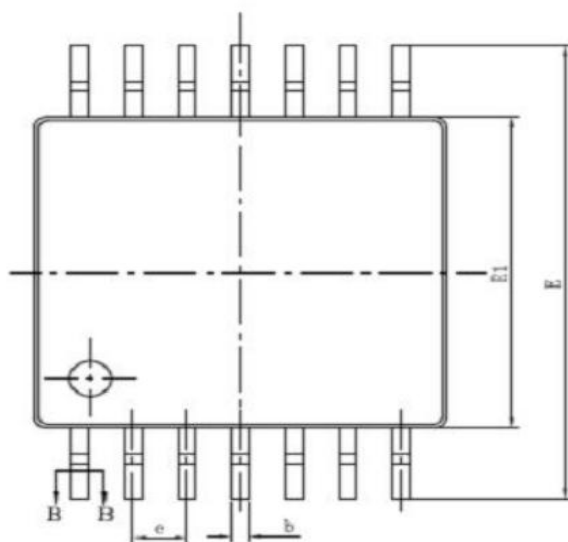
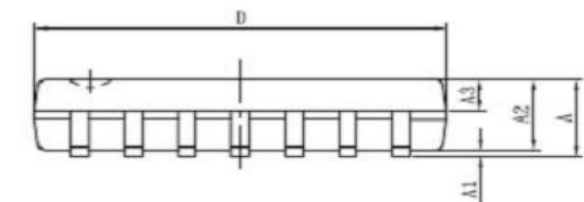

SYMBOL	MILLIMETER	
	MIN	MAX
A	-	1.20
A1	0.05	0.15
A2	0.90	1.05
A3	0.39	0.49
b	0.20	0.30
b1	0.19	0.25
c	0.13	0.19
c1	0.12	0.14
D	4.86	5.06
E1	4.30	4.50
E	6.20	6.60
e	0.65BSC	
L	0.45	0.75
L1	1.00BSC	
θ	0°	8°



Statement:

- ✧ Shenzhen xinbole electronics co., ltd. reserves the right to change the product specifications, without notice!
Before placing an order, the customer needs to confirm whether the information obtained is the latest version, and verify the integrity of the relevant information.
- ✧ Any semiconductor product is liable to fail or malfunction under certain conditions, and the buyer shall be responsible for complying with safety standards in the system design and whole machine manufacturing using Shenzhen xinbole electronics co., ltd products, and take appropriate security measures to avoid the potential risk of failure may result in personal injury or property losses of the situation occurred!
- ✧ This document is for reference only, and the actual use should be based on the application test results.
- ✧ Product performance is never ending, Shenzhen xinbole electronics co., ltd will be dedicated to provide customers with better performance, better quality of integrated circuit products.

Version revision history:

Version	Date	Information
version1.0	2019-03	New document
version2.0	2023-11	Add ordering information: 1,SN74HC14TDTR TSSOP-14. 2,SN74HCT14N DIP-14

单击下面可查看定价，库存，交付和生命周期等信息

[>>XBLW\(芯伯乐\)](#)