

General Description

The SN74HC/HCT42 is a one of ten BCD to decimal decoder. It accepts four BCD inputs (0A to 3A) and provides ten mutually exclusive outputs (0 \bar{Y} to 9 \bar{Y}). The logic design ensures that all outputs are HIGH when binary codes greater than nine are applied to the inputs. The most significant input (3A) produces an useful inhibit function when the device is used as a 1-of-8 decoder. The 3A input can also be used as the data input in an 8-output demultiplexer application. Inputs include clamp diodes. This enables the use of current limiting resistors to interface inputs to voltages in excess of V_{CC} .

Features

- Input levels:
For SN74HC42: CMOS level
For SN74HCT42: TTL level
- Mutually exclusive outputs
- 1-of-8 demultiplexing capability
- Outputs disabled for input codes above nine
- Specified from -40°C to +125°C
- Packaging information: DIP16/SOP16/TSSOP16

Ordering Information

Product Model	Package Type	Marking	Packing	Packing Qty
XBLW SN74HC42N	DIP-16	74HC42N	Tube	1000Pcs/Box
XBLW SN74HC42DTR	SOP-16	74HC42	Tape	2500Pcs/Reel
XBLW SN74HC42TDTR	TSSOP-16	74HC42	Tape	3000Pcs/Reel
XBLW SN74HCT42N	DIP-16	74HCT42N	Tube	1000Pcs/Box
XBLW SN74HCT42DTR	SOP-16	74HCT42	Tape	2500Pcs/Reel
XBLW SN74HCT42TDTR	TSSOP-16	74HCT42	Tape	3000Pcs/Reel

Block Diagram And Pin Description

2.1、Block Diagram

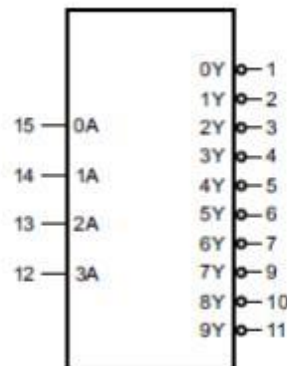

Figure 1. Logic symbol

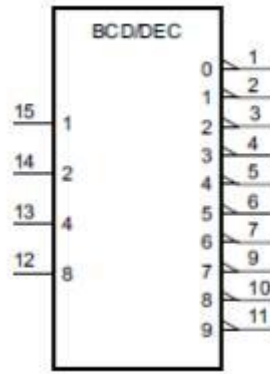

Figure 2. IEC logic symbol

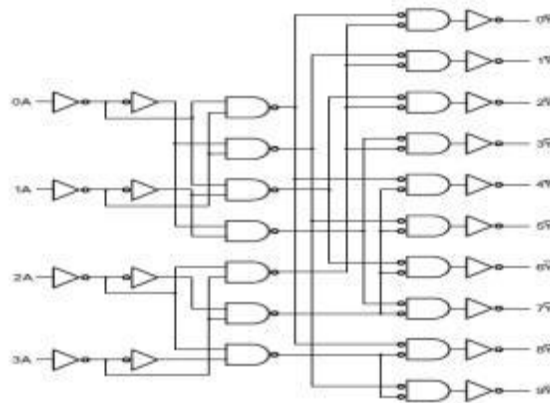
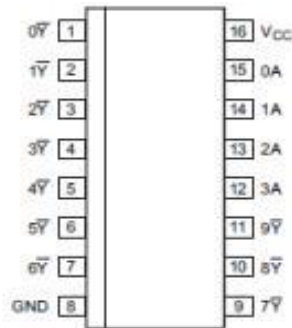

Figure 4. Logic diagram

Pin Configurations



Pin Description

Pin No.	Pin Name	Description
1	0 \bar{Y}	multiplexer output
2	1 \bar{Y}	multiplexer output
3	2 \bar{Y}	multiplexer output
4	3 \bar{Y}	multiplexer output
5	4 \bar{Y}	multiplexer output
6	5 \bar{Y}	multiplexer output
7	6 \bar{Y}	multiplexer output
8	GND	ground (0V)
9	7 \bar{Y}	multiplexer output
10	8 \bar{Y}	multiplexer output
11	9 \bar{Y}	multiplexer output

12	3A	data input
13	2A	data input
14	1A	data input
15	0A	data input
16	V _{CC}	supply voltage

Function Table

Input				Output									
3A	2A	1A	0A	0 \bar{Y}	1 \bar{Y}	2 \bar{Y}	3 \bar{Y}	4 \bar{Y}	5 \bar{Y}	6 \bar{Y}	7 \bar{Y}	8 \bar{Y}	9 \bar{Y}
L	L	L	L	L	H	H	H	H	H	H	H	H	H
L	L	L	H	H	L	H	H	H	H	H	H	H	H
L	L	H	L	H	H	L	H	H	H	H	H	H	H
L	L	H	H	H	H	H	L	H	H	H	H	H	H
L	H	L	L	H	H	H	H	L	H	H	H	H	H
L	H	L	H	H	H	H	H	H	L	H	H	H	H
L	H	H	L	H	H	H	H	H	H	L	H	H	H
L	H	H	H	H	H	H	H	H	H	H	L	H	H
H	L	L	L	H	H	H	H	H	H	H	H	L	H
H	L	L	H	H	H	H	H	H	H	H	H	H	L
H	L	H	L	H	H	H	H	H	H	H	H	H	H
H	L	H	H	H	H	H	H	H	H	H	H	H	H
H	H	L	L	H	H	H	H	H	H	H	H	H	H
H	H	L	H	H	H	H	H	H	H	H	H	H	H
H	H	H	L	H	H	H	H	H	H	H	H	H	H
H	H	H	H	H	H	H	H	H	H	H	H	H	H

Note: H=HIGH voltage level; L=LOW voltage level.

Electrical Parameter

Absolute Maximum Ratings

(Voltages are referenced to GND (ground=0V), unless otherwise specified.)

Parameter	Symbol	Conditions	Min.	Max.	Unit
supply voltage	V _{CC}	-	-0.5	+7.0	V
input clamping current	I _{IK}	V _I < -0.5V or V _I > V _{CC} +0.5V	-	±20	mA
output clamping current	I _{OK}	V _O < -0.5V or V _O > V _{CC} +0.5V	-	±20	mA
output current	I _O	-0.5V < V _O < V _{CC} +0.5V	-	±25	mA
supply current	I _{CC}	-	-	+50	mA
ground current	I _{GND}	-	-50	-	mA
storage temperature	T _{stg}	-	-65	+150	°C
total power dissipation	P _{tot}	-	-	500	mW
soldering temperature	T _L	10s	DIP		°C
			SOP/TSSOP		

Recommended Operating Conditions

Parameter	Symbol	Conditions	Min.	Typ.	Max.	Unit
SN74HC42						
supply voltage	V_{CC}	-	2.0	5.0	6.0	V
input voltage	V_I	-	0	-	V_{CC}	V
output voltage	V_O	-	0	-	V_{CC}	V
input transition rise and fall rate	$\Delta t/\Delta V$	$V_{CC}=2.0V$	-	-	625	ns/V
		$V_{CC}=4.5V$	-	1.67	139	ns/V
		$V_{CC}=6.0V$	-	-	83	ns/V
ambient temperature	T_{amb}	-	-40	-	+125	°C
SN74HCT42						
supply voltage	V_{CC}	-	4.5	5.0	5.5	V
input voltage	V_I	-	0	-	V_{CC}	V
output voltage	V_O	-	0	-	V_{CC}	V
input transition rise and fall rate	$\Delta t/\Delta V$	$V_{CC}=4.5V$	-	1.67	139	ns/V
ambient temperature	T_{amb}	-	-40	-	+125	°C

Electrical Characteristics

3.3.1、DC Characteristics 1

($T_{amb}=25^{\circ}C$, voltages are referenced to GND (ground=0V), unless otherwise specified.)

Parameter	Symbol	Conditions	Min.	Typ.	Max.	Unit	
SN74HC42							
HIGH-level input voltage	V_{IH}	$V_{CC}=2.0V$	1.5	1.2	-	V	
		$V_{CC}=4.5V$	3.15	2.4	-	V	
		$V_{CC}=6.0V$	4.2	3.2	-	V	
LOW-level input voltage	V_{IL}	$V_{CC}=2.0V$	-	0.8	0.5	V	
		$V_{CC}=4.5V$	-	2.1	1.35	V	
		$V_{CC}=6.0V$	-	2.8	1.8	V	
HIGH-level output voltage	V_{OH}	$V_I=V_{IH}$ or V_{IL}	$I_O=-20\mu A; V_{CC}=2.0V$	1.9	2.0	-	V
			$I_O=-20\mu A; V_{CC}=4.5V$	4.4	4.5	-	V
			$I_O=-20\mu A; V_{CC}=6.0V$	5.9	6.0	-	V
			$I_O=-4.0mA; V_{CC}=4.5V$	3.98	4.32	-	V
			$I_O=-5.2mA; V_{CC}=6.0V$	5.48	5.81	-	V
LOW-level output voltage	V_{OL}	$V_I=V_{IH}$ or V_{IL}	$I_O=20\mu A; V_{CC}=2.0V$	-	0	0.1	V
			$I_O=20\mu A; V_{CC}=4.5V$	-	0	0.1	V
			$I_O=20\mu A; V_{CC}=6.0V$	-	0	0.1	V
			$I_O=4.0mA; V_{CC}=4.5V$	-	0.15	0.26	V
			$I_O=5.2mA; V_{CC}=6.0V$	-	0.16	0.26	V
input leakage current	I_I	$V_I=V_{CC}$ or GND; $V_{CC}=6.0V$	-	-	± 1.0	μA	
supply current	I_{CC}	$V_I=V_{CC}$ or GND; $I_O=0A; V_{CC}=6.0V$	-	-	8.0	μA	
input capacitance	C_I	-	-	3.5	-	pF	
SN74HCT42							

HIGH-level input voltage	V_{IH}	$V_{CC}=4.5V$ to $5.5V$	2.0	1.6	-	V	
LOW-level input voltage	V_{IL}	$V_{CC}=4.5V$ to $5.5V$	-	1.2	0.8	V	
HIGH-level output voltage	V_{OH}	$V_I=V_{IH}$ or V_{IL} ; $V_{CC}=4.5V$	$I_O=-20\mu A$	4.4	4.5	-	V
			$I_O=-4.0mA$	3.98	4.32	-	V
LOW-level output voltage	V_{OL}	$V_I=V_{IH}$ or V_{IL} ; $V_{CC}=4.5V$	$I_O=20\mu A$	-	0	0.1	V
			$I_O=4.0mA$	-	0.16	0.26	V
input leakage current	I_I	$V_I=V_{CC}$ or GND; $V_{CC}=5.5V$	-	-	± 1.0	μA	
supply current	I_{CC}	$V_I=V_{CC}$ or GND; $I_O=0A$; $V_{CC}=5.5V$	-	-	8.0	μA	
additional supply current	ΔI_{CC}	$V_I=V_{CC}-2.1V$; other inputs at V_{CC} or GND; $I_O=0A$; $V_{CC}=4.5V$ to $5.5V$	-	-	360	μA	
input capacitance	C_I	-	-	3.5	-	pF	

DC Characteristics 2

($T_{amb}=-40^{\circ}C$ to $+85^{\circ}C$, voltages are referenced to GND (ground=0V), unless otherwise specified.)

Parameter	Symbol	Conditions	Min.	Typ.	Max.	Unit	
SN74HC42							
HIGH-level input voltage	V_{IH}	$V_{CC}=2.0V$	1.5	-	-	V	
		$V_{CC}=4.5V$	3.15	-	-	V	
		$V_{CC}=6.0V$	4.2	-	-	V	
LOW-level input voltage	V_{IL}	$V_{CC}=2.0V$	-	-	0.5	V	
		$V_{CC}=4.5V$	-	-	1.35	V	
		$V_{CC}=6.0V$	-	-	1.8	V	
HIGH-level output voltage	V_{OH}	$V_I=V_{IH}$ or V_{IL}	$I_O=-20\mu A$; $V_{CC}=2.0V$	1.9	-	-	V
			$I_O=-20\mu A$; $V_{CC}=4.5V$	4.4	-	-	V
			$I_O=-20\mu A$; $V_{CC}=6.0V$	5.9	-	-	V
			$I_O=-4.0mA$; $V_{CC}=4.5V$	3.84	-	-	V
			$I_O=-5.2mA$; $V_{CC}=6.0V$	5.34	-	-	V
LOW-level output voltage	V_{OL}	$V_I=V_{IH}$ or V_{IL}	$I_O=20\mu A$; $V_{CC}=2.0V$	-	-	0.1	V
			$I_O=20\mu A$; $V_{CC}=4.5V$	-	-	0.1	V
			$I_O=20\mu A$; $V_{CC}=6.0V$	-	-	0.1	V
			$I_O=4.0mA$; $V_{CC}=4.5V$	-	-	0.33	V
			$I_O=5.2mA$; $V_{CC}=6.0V$	-	-	0.33	V
input leakage current	I_I	$V_I=V_{CC}$ or GND; $V_{CC}=6.0V$	-	-	± 1.0	μA	
supply current	I_{CC}	$V_I=V_{CC}$ or GND; $I_O=0A$; $V_{CC}=6.0V$	-	-	80	μA	
SN74HCT42							
HIGH-level input voltage	V_{IH}	$V_{CC}=4.5V$ to $5.5V$	2.0	-	-	V	
LOW-level input voltage	V_{IL}	$V_{CC}=4.5V$ to $5.5V$	-	-	0.8	V	
HIGH-level output voltage	V_{OH}	$V_I=V_{IH}$ or V_{IL} ; $V_{CC}=4.5V$	$I_O=-20\mu A$	4.4	-	-	V
			$I_O=-4.0mA$	3.84	-	-	V

LOW-level output voltage	V_{OL}	$V_I=V_{IH}$ or V_{IL} ; $V_{CC}=4.5V$	$I_O=20\mu A$	-	-	0.1	V
			$I_O=4.0mA$	-	-	0.33	V
input leakage current	I_I	$V_I=V_{CC}$ or GND; $V_{CC}=5.5V$	-	-	± 1.0	μA	
supply current	I_{CC}	$V_I=V_{CC}$ or GND; $I_O=0A$; $V_{CC}=5.5V$	-	-	80	μA	
additional supply current	ΔI_{CC}	$V_I=V_{CC}-2.1V$; other inputs at V_{CC} or GND; $I_O=0A$; $V_{CC}=4.5V$ to $5.5V$	-	-	450	μA	

DC Characteristics 3

($T_{amb}=-40^{\circ}C$ to $+125^{\circ}C$, voltages are referenced to GND (ground=0V), unless otherwise specified.)

Parameter	Symbol	Conditions	Min.	Typ.	Max.	Unit	
SN74HC42							
HIGH-level input voltage	V_{IH}	$V_{CC}=2.0V$	1.5	-	-	V	
		$V_{CC}=4.5V$	3.15	-	-	V	
		$V_{CC}=6.0V$	4.2	-	-	V	
LOW-level input voltage	V_{IL}	$V_{CC}=2.0V$	-	-	0.5	V	
		$V_{CC}=4.5V$	-	-	1.35	V	
		$V_{CC}=6.0V$	-	-	1.8	V	
HIGH-level output voltage	V_{OH}	$V_I=V_{IH}$ or V_{IL}	$I_O=-20\mu A$; $V_{CC}=2.0V$	1.9	-	-	V
			$I_O=-20\mu A$; $V_{CC}=4.5V$	4.4	-	-	V
			$I_O=-20\mu A$; $V_{CC}=6.0V$	5.9	-	-	V
			$I_O=-4.0mA$; $V_{CC}=4.5V$	3.7	-	-	V
			$I_O=-5.2mA$; $V_{CC}=6.0V$	5.2	-	-	V
LOW-level output voltage	V_{OL}	$V_I=V_{IH}$ or V_{IL}	$I_O=20\mu A$; $V_{CC}=2.0V$	-	-	0.1	V
			$I_O=20\mu A$; $V_{CC}=4.5V$	-	-	0.1	V
			$I_O=20\mu A$; $V_{CC}=6.0V$	-	-	0.1	V
			$I_O=4.0mA$; $V_{CC}=4.5V$	-	-	0.4	V
			$I_O=5.2mA$; $V_{CC}=6.0V$	-	-	0.4	V
input leakage current	I_I	$V_I=V_{CC}$ or GND; $V_{CC}=6.0V$	-	-	± 1.0	μA	
supply current	I_{CC}	$V_I=V_{CC}$ or GND; $I_O=0A$; $V_{CC}=6.0V$	-	-	160	μA	
SN74HCT42							
HIGH-level input voltage	V_{IH}	$V_{CC}=4.5V$ to $5.5V$	2.0	-	-	V	
LOW-level input voltage	V_{IL}	$V_{CC}=4.5V$ to $5.5V$	-	-	0.8	V	
HIGH-level output voltage	V_{OH}	$V_I=V_{IH}$ or V_{IL} ; $V_{CC}=4.5V$	$I_O=-20\mu A$	4.4	-	-	V
			$I_O=-4.0mA$	3.7	-	-	V
LOW-level output voltage	V_{OL}	$V_I=V_{IH}$ or V_{IL} ; $V_{CC}=4.5V$	$I_O=20\mu A$	-	-	0.1	V
			$I_O=4.0mA$	-	-	0.4	V
input leakage current	I_I	$V_I=V_{CC}$ or GND; $V_{CC}=5.5V$	-	-	± 1.0	μA	
supply current	I_{CC}	$V_I=V_{CC}$ or GND; $I_O=0A$; $V_{CC}=5.5V$	-	-	160	μA	
additional supply current	ΔI_{CC}	$V_I=V_{CC}-2.1V$; other inputs at V_{CC} or GND; $I_O=0A$; $V_{CC}=4.5V$ to $5.5V$	-	-	490	μA	

AC Characteristics 1

($T_{amb}=25^{\circ}\text{C}$, $\text{GND}=0\text{V}$, $C_L=50\text{pF}$, unless otherwise specified.)

Parameter	Symbol	Conditions	Min.	Typ.	Max.	Unit	
SN74HC42							
nA ton \bar{Y} propagation delay	t_{pd}	see Figure 6 ^[1]	$V_{CC}=2.0\text{V}$	-	47	150	ns
			$V_{CC}=4.5\text{V}$	-	17	30	ns
			$V_{CC}=5.0\text{V}; C_L=15\text{pF}$	-	17	-	ns
			$V_{CC}=6.0\text{V}$	-	14	26	ns
transition time	t_t	see Figure 6 ^[2]	$V_{CC}=2.0\text{V}$	-	19	75	ns
			$V_{CC}=4.5\text{V}$	-	7	15	ns
			$V_{CC}=6.0\text{V}$	-	6	13	ns
power dissipation capacitance	C_{PD}	per package; $V_I=\text{GND}$ to V_{CC} ^[3]	-	37	-	pF	
SN74HCT42							
nA ton \bar{Y} propagation delay	t_{pd}	see Figure 6 ^[1]	$V_{CC}=4.5\text{V}$	-	20	35	ns
			$V_{CC}=5.0\text{V}; C_L=15\text{pF}$	-	17	-	ns
transition time	t_t	$V_{CC}=4.5\text{V}$; see Figure 6 ^[2]	-	7	15	ns	
power dissipation capacitance	C_{PD}	per package; $V_I=\text{GND}$ to $V_{CC}-1.5\text{V}$ ^[3]	-	37	-	pF	

Note:

[1] t_{pd} is the same as t_{PLH} and t_{PHL} .

[2] t_t is the same as t_{THL} and t_{TLH} .

[3] C_{PD} is used to determine the dynamic power dissipation (P_D in uW).

$P_D=C_{PD}\times V_{CC}^2\times f_i\times N+\Sigma(C_L\times V_{CC}^2\times f_o)$ where:

f_i =input frequency in MHz;

f_o =output frequency in MHz;

C_L =output load capacitance in pF;

V_{CC} =supply voltage in V;

N =number of inputs switching;

$\Sigma(C_L\times V_{CC}^2\times f_o)$ =sum of outputs

AC Characteristics 2

($T_{amb}=-40^{\circ}\text{C}$ to $+85^{\circ}\text{C}$, $\text{GND}=0\text{V}$, $C_L=50\text{pF}$, unless otherwise specified.)

Parameter	Symbol	Conditions	Min.	Typ.	Max.	Unit	
SN74HC42							
nA ton \bar{Y} propagation delay	t_{pd}	see Figure 6 ^[1]	$V_{CC}=2.0\text{V}$	-	-	190	ns
			$V_{CC}=4.5\text{V}$	-	-	38	ns
			$V_{CC}=6.0\text{V}$	-	-	33	ns
transition time	t_t	see Figure 6 ^[2]	$V_{CC}=2.0\text{V}$	-	-	95	ns
			$V_{CC}=4.5\text{V}$	-	-	19	ns
			$V_{CC}=6.0\text{V}$	-	-	16	ns
SN74HCT42							
nA ton \bar{Y} propagation delay	t_{pd}	see Figure 6 ^[1]	$V_{CC}=4.5\text{V}$	-	-	44	ns
transition time	t_t	$V_{CC}=4.5\text{V}$; see Figure 6 ^[2]	-	-	19	ns	

Note:

[1] t_{pd} is the same as t_{PLH} and t_{PHL} .

[2] t_t is the same as t_{THL} and t_{TLH} .

AC Characteristics 3

($T_{amb} = -40^{\circ}\text{C}$ to $+125^{\circ}\text{C}$, $GND = 0\text{V}$, $C_L = 50\text{pF}$, unless otherwise specified.)

Parameter	Symbol	Conditions	Min.	Typ.	Max.	Unit		
SN74HC42								
nA ton \bar{Y} propagation delay	t_{pd}	see Figure 6 ^[1]	$V_{CC} = 2.0\text{V}$	-	-	225	ns	
			$V_{CC} = 4.5\text{V}$	-	-	45	ns	
			$V_{CC} = 6.0\text{V}$	-	-	38	ns	
transition time	t_t	see Figure 6 ^[2]	$V_{CC} = 2.0\text{V}$	-	-	110	ns	
			$V_{CC} = 4.5\text{V}$	-	-	22	ns	
			$V_{CC} = 6.0\text{V}$	-	-	19	ns	
SN74HCT42								
nA ton \bar{Y} propagation delay	t_{pd}	see Figure 6 ^[1]	$V_{CC} = 4.5\text{V}$		-	-	53	ns
transition time	t_t	$V_{CC} = 4.5\text{V}$; see Figure 6 ^[2]		-	-	22	ns	

Note:

[1] t_{pd} is the same as t_{PLH} and t_{PHL} .

[2] t_t is the same as t_{THL} and t_{TLH} .

Testing Circuit

AC Testing Circuit

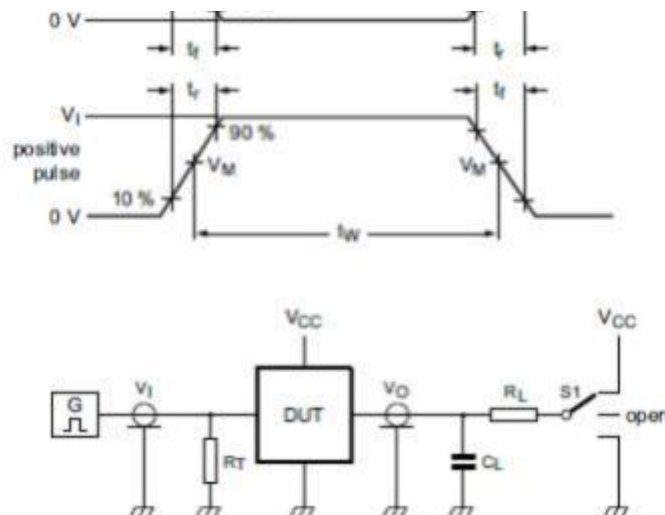

Figure 5. Test circuit for measuring switching times

Definitions for test circuit:

C_L =Load capacitance including jig and probe capacitance.

R_T =Termination resistance should be equal to the output impedance Z_o of the pulse generator. R_L =Load resistance.

S1=Test selection switch

AC Testing Waveforms

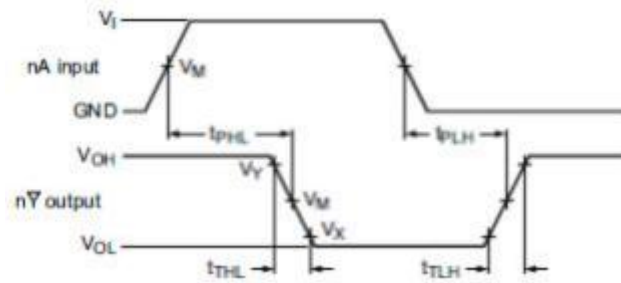

Figure 6. Input (nA) to output (nY) propagation delays and output transition times

Measurement Points

Type	Input	Output		
	V_M	V_M	V_X	V_Y
SN74HC42	$0.5 \times V_{CC}$	$0.5 \times V_{CC}$	$0.1 \times V_{CC}$	$0.9 \times V_{CC}$
SN74HCT42	1.3V	1.3V	$0.1 \times V_{CC}$	$0.9 \times V_{CC}$

Test Data

Type	Input		Load		S1 position t_{PLH}, t_{PHL}
	V_I	t_r, t_f	C_L	R_L	
SN74HC42	V_{CC}	6ns	15pF, 50pF	1k Ω	open
SN74HCT42	3V	6ns	15pF, 50pF	1k Ω	open

Package Information

DIP16

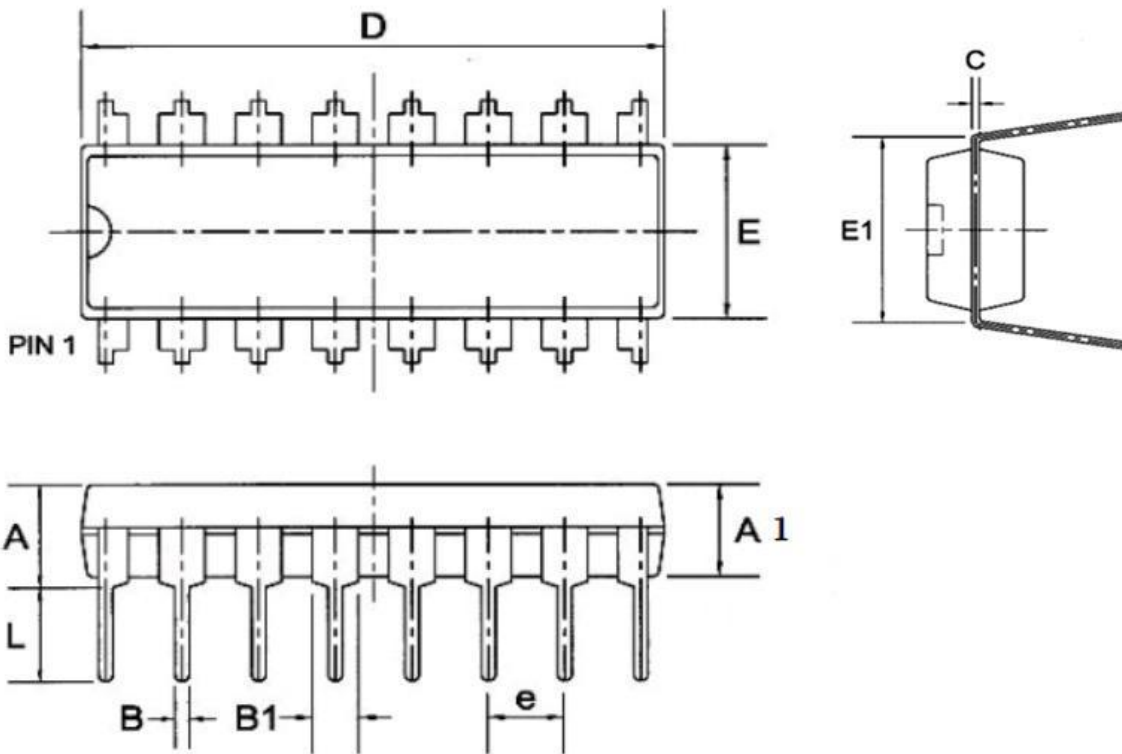

Symbol	Dimensions in Millimeters		
	Min	Nom	Max
A	--	--	4.31
A1	3.15	3.30	3.65
B	--	0.50	--
B1	--	1.6	--
C	--	0.27	--
D	19.00	19.20	19.60
E	6.20	6.50	6.60
E1	--	8.0	--
e	--	2.3	--
L	3.00	3.20	3.60

SOP16

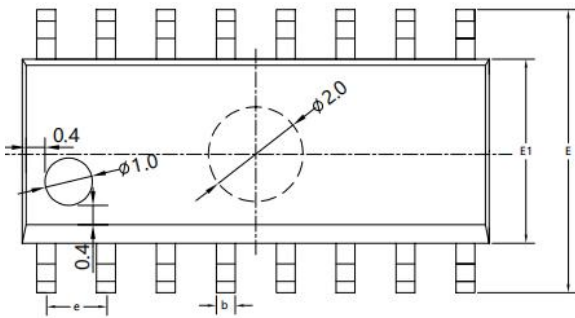
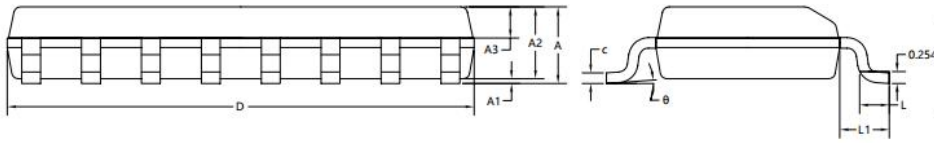

SYMBOL	MILLIMETER		
	MIN	NOM	MAX
A	1.50	1.60	1.70
A1	0.10	0.15	0.25
A2	1.40	1.45	1.50
A3	0.60	0.65	0.70
b	0.30	0.40	0.50
c	0.15	0.20	0.25
D	9.80	9.90	10.00
E	5.80	6.00	6.20
E1	3.85	3.90	3.95
e	1.27BSC		
L	0.50	0.60	0.70
L1	1.05BSC		
θ	0°	4°	8°

TSSOP16

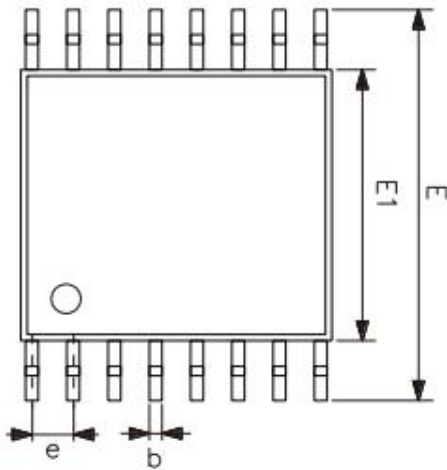
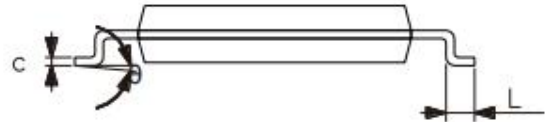
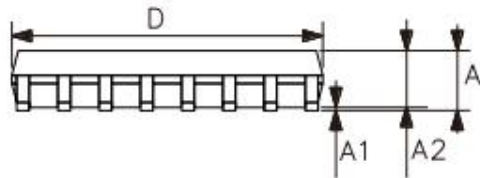

Symbol	Dimensions (mm)	
	Min.	Max.
A	-	1.20
A1	0.05	0.15
A2	0.80	1.05
b	0.19	0.30
c	0.09	0.20
D	4.90	5.10
E1	4.30	4.50
E	6.20	6.60
e	0.65	
L	0.45	0.75
θ	0°	8°

Statement:

- ✧ Shenzhen xinbole electronics co., ltd. reserves the right to change the product specifications, without notice! Before placing an order, the customer needs to confirm whether the information obtained is the latest version, and verify the integrity of the relevant information.
- ✧ Any semiconductor product is liable to fail or malfunction under certain conditions, and the buyer shall be responsible for complying with safety standards in the system design and whole machine manufacturing using Shenzhen xinbole electronics co., ltd products, and take appropriate security measures to avoid the potential risk of failure may result in personal injury or property losses of the situation occurred!
- ✧ This document is for reference only, and the actual use should be based on the application test results.
- ✧ Product performance is never ending, Shenzhen xinbole electronics co., ltd will be dedicated to provide customers with better performance, better quality of integrated circuit products.

单击下面可查看定价，库存，交付和生命周期等信息

[>>XBLW\(芯伯乐\)](#)