

Product Specification

XBLW SN74LS02

Quad 2-input Nor Gate

WEB | www.xinboleic.com



Description

The SN74LS02 is a quad 2-input NOR gate. Inputs include clamp diodes. This enables the use of current limiting resistors to interface inputs to voltages in excess of V_{CC} .

Features

- Wide operating voltage range: 2 V to 6 V
- Specified from -20°C to +85°C
- Packaging information: DIP-14/SOP-14/TSSOP-14

Applications

- Alarm / tamper detect circuit
- S-R latch

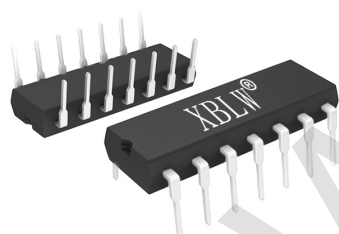

DIP-14

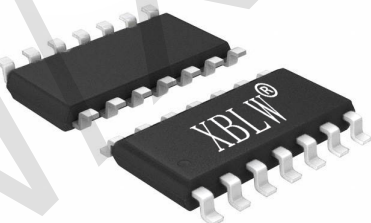

SOP-14

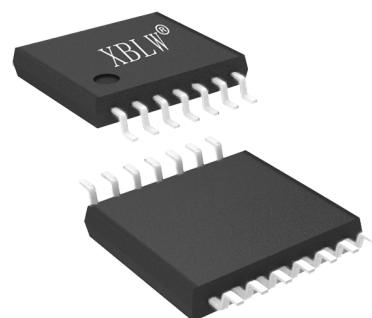

TSSOP-14

Ordering Information

Product Model	Package Type	Marking	Packing	Packing Qty
XBLW SN74LS02N	DIP-14	74LS02N	Tube	1000Pcs/Box
XBLW SN74LS02DTR	SOP-14	74LS02	Tape	2500Pcs/Reel
XBLW SN74LS02TDTR	TSSOP-14	74LS02	Tape	3000Pcs/Reel

Block Diagram

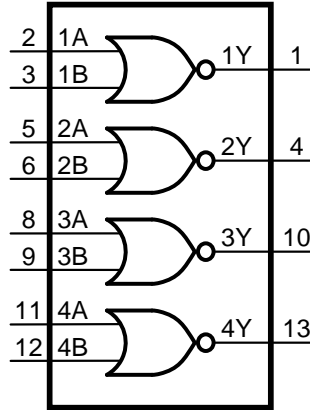

Figure 1. Logic symbol

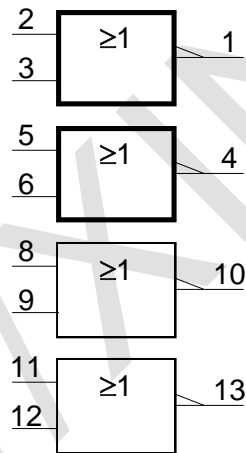

Figure 2. IEC logic symbol

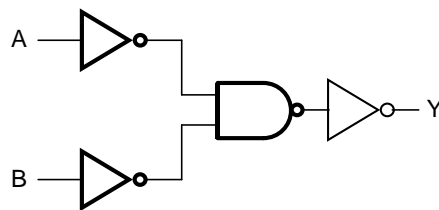
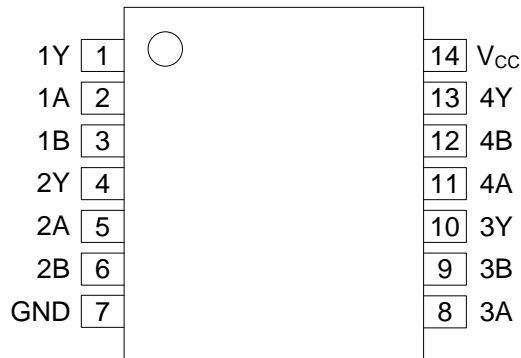

Figure 3. Logic diagram for one gate

Pin Configurations



Pin Description

Pin No.	Pin Name	Description
1	1Y	data output
2	1A	data input
3	1B	data input
4	2Y	data output
5	2A	data input
6	2B	data input
7	GND	ground (0V)
8	3A	data input
9	3B	data input
10	3Y	data output
11	4A	data input
12	4B	data input
13	4Y	data output
14	V _{CC}	supply voltage

Function Table

Input		Output
nA	nB	nY
L	L	H
X	H	L
H	X	L

Note: H=HIGH voltage level; L=LOW voltage level; X=don't care.

Electrical Parameter

Absolute Maximum Ratings

(Voltages are referenced to GND (ground=0V), unless otherwise specified.)

Parameter	Symbol	Conditions	Min.	Max.	Unit
supply voltage	V_{CC}	-	-0.5	+7	V
input clamping current	I_{IK}	$V_I < -0.5V$ or $V_I > V_{CC}+0.5V$	-	± 20	mA
output clamping current	I_{OK}	$V_O < -0.5V$ or $V_O > V_{CC}+0.5V$	-	± 20	mA
output current	I_O	$-0.5V < V_O < V_{CC}+0.5V$	-	± 25	mA
supply current	I_{CC}	-	-	50	mA
ground current	I_{GND}	-	-50	-	mA
total power dissipation	P_{tot}	-	-	500	mW
storage temperature	T_{stg}	-	-65	+150	°C
Soldering temperature	T_L	10s	DIP	245	°C
			SOP/TSSOP	260	°C

Recommended Operating Conditions

Parameter	Symbol	Conditions	Min.	Typ.	Max.	Unit
supply voltage	V_{CC}	-	2.0	5.0	6.0	V
input voltage	V_I	-	0	-	V_{CC}	V
output voltage	V_O	-	0	-	V_{CC}	V
input transition rise and fall rate	$\Delta t/\Delta V$	$V_{CC}=2.0V$	-	-	625	ns/V
		$V_{CC}=4.5V$	-	1.67	139	ns/V
		$V_{CC}=6.0V$	-	-	83	ns/V
ambient temperature	T_{amb}	-	-20	-	+85	°C

Electrical Characteristics

DC Characteristics 1

($T_{amb}=25^{\circ}\text{C}$, voltages are referenced to GND (ground=0V), unless otherwise specified.)

Parameter	Symbol	Conditions	Min.	Typ.	Max.	Unit	
HIGH-level input voltage	V_{IH}	$V_{CC}=2.0\text{V}$	1.5	1.2	-	V	
		$V_{CC}=4.5\text{V}$	3.15	2.4	-	V	
		$V_{CC}=6.0\text{V}$	4.2	3.2	-	V	
LOW-level input voltage	V_{IL}	$V_{CC}=2.0\text{V}$	-	0.8	0.5	V	
		$V_{CC}=4.5\text{V}$	-	2.1	1.35	V	
		$V_{CC}=6.0\text{V}$	-	2.8	1.8	V	
HIGH-level output voltage	V_{OH}	$V_I=V_{IH}$ or V_{IL}	$I_O=-20\mu\text{A}; V_{CC}=2.0\text{V}$	1.9	2.0	-	V
			$I_O=-20\mu\text{A}; V_{CC}=4.5\text{V}$	4.4	4.5	-	V
			$I_O=-20\mu\text{A}; V_{CC}=6.0\text{V}$	5.9	6.0	-	V
			$I_O=-4.0\text{mA}; V_{CC}=4.5\text{V}$	3.98	4.32	-	V
			$I_O=-5.2\text{mA}; V_{CC}=6.0\text{V}$	5.48	5.81	-	V
LOW-level output voltage	V_{OL}	$V_I=V_{IH}$ or V_{IL}	$I_O=20\mu\text{A}; V_{CC}=2.0\text{V}$	-	0	0.1	V
			$I_O=20\mu\text{A}; V_{CC}=4.5\text{V}$	-	0	0.1	V
			$I_O=20\mu\text{A}; V_{CC}=6.0\text{V}$	-	0	0.1	V
			$I_O=4.0\text{mA}; V_{CC}=4.5\text{V}$	-	0.15	0.26	V
			$I_O=5.2\text{mA}; V_{CC}=6.0\text{V}$	-	0.16	0.26	V
input leakage current	I_I	$V_I=V_{CC}$ or GND; $V_{CC}=6.0\text{V}$	-	-	± 1	μA	
supply current	I_{CC}	$V_I=V_{CC}$ or GND; $I_O=0\text{A}; V_{CC}=6.0\text{V}$	-	-	2.0	μA	
input capacitance	C_I	-	-	3.5	-	pF	

DC Characteristics 2

($T_{amb}=-20^{\circ}\text{C}$ to $+85^{\circ}\text{C}$, voltages are referenced to GND (ground=0V), unless otherwise specified.)

Parameter	Symbol	Conditions	Min.	Typ.	Max.	Unit	
HIGH-level input voltage	V_{IH}	$V_{CC}=2.0\text{V}$	1.5	-	-	V	
		$V_{CC}=4.5\text{V}$	3.15	-	-	V	
		$V_{CC}=6.0\text{V}$	4.2	-	-	V	
LOW-level input voltage	V_{IL}	$V_{CC}=2.0\text{V}$	-	-	0.5	V	
		$V_{CC}=4.5\text{V}$	-	-	1.35	V	
		$V_{CC}=6.0\text{V}$	-	-	1.8	V	
HIGH-level output voltage	V_{OH}	$V_I=V_{IH}$ or V_{IL}	$I_O=-20\mu\text{A}; V_{CC}=2.0\text{V}$	1.9	-	-	V
			$I_O=-20\mu\text{A}; V_{CC}=4.5\text{V}$	4.4	-	-	V
			$I_O=-20\mu\text{A}; V_{CC}=6.0\text{V}$	5.9	-	-	V
			$I_O=-4.0\text{mA}; V_{CC}=4.5\text{V}$	3.84	-	-	V
			$I_O=-5.2\text{mA}; V_{CC}=6.0\text{V}$	5.34	-	-	V
LOW-level output voltage	V_{OL}	$V_I=V_{IH}$ or V_{IL}	$I_O=20\mu\text{A}; V_{CC}=2.0\text{V}$	-	-	0.1	V
			$I_O=20\mu\text{A}; V_{CC}=4.5\text{V}$	-	-	0.1	V
			$I_O=20\mu\text{A}; V_{CC}=6.0\text{V}$	-	-	0.1	V
			$I_O=4.0\text{mA}; V_{CC}=4.5\text{V}$	-	-	0.33	V
			$I_O=5.2\text{mA}; V_{CC}=6.0\text{V}$	-	-	0.33	V
input leakage current	I_I	$V_I=V_{CC}$ or GND; $V_{CC}=6.0\text{V}$	-	-	± 1	μA	
supply current	I_{CC}	$V_I=V_{CC}$ or GND; $I_O=0\text{A}; V_{CC}=6.0\text{V}$	-	-	20	μA	

AC Characteristics 1

($T_{amb}=25^{\circ}C$, voltages are referenced to GND (ground=0V), unless otherwise specified.)

Parameter	Symbol	Conditions	Min.	Typ.	Max.	Unit	
nA, nB to nY propagation delay	t_{pd}	see Figure 5 ^[1]	$V_{CC}=2.0V$	-	25	90	ns
			$V_{CC}=4.5V$	-	9	18	ns
			$V_{CC}=5.0V; C_L=15pF$	-	7	-	ns
			$V_{CC}=6.0V$	-	7	15	ns
transition time	t_t	see Figure 5 ^[2]	$V_{CC}=2.0V$	-	19	75	ns
			$V_{CC}=4.5V$	-	7	15	ns
			$V_{CC}=6.0V$	-	6	13	ns
power dissipation capacitance	C_{PD}	per package; $V_I = GND$ to V_{CC} ^[3]	-	22	-	pF	

Note:

[1] t_{pd} is the same as t_{PLH} and t_{PHL} .

[2] t_t is the same as t_{THL} and t_{TLH} .

[3] C_{PD} is used to determine the dynamic power dissipation (P_D in uW).

$P_D = (C_{PD} \times V_{CC}^2 \times f_i \times N) + \sum (C_L \times V_{CC}^2 \times f_o)$ where: f_i =input frequency in MHz;

f_o =output frequency in MHz;

C_L =output load capacitance in pF; V_{CC} =supply voltage in V;

N =number of inputs switching; $\sum (C_L \times V_{CC}^2 \times f_o)$ =sum of outputs.

AC Characteristics 2

($T_{amb}=-20^{\circ}C$ to $+85^{\circ}C$, voltages are referenced to GND (ground=0V), unless otherwise specified.)

Parameter	Symbol	Conditions	Min.	Typ.	Max.	Unit	
nA, nB to nY propagation delay	t_{pd}	see Figure 5 ^[1]	$V_{CC}=2.0V$	-	-	115	ns
			$V_{CC}=4.5V$	-	-	23	ns
			$V_{CC}=6.0V$	-	-	20	ns
transition time	t_t	see Figure 5 ^[2]	$V_{CC}=2.0V$	-	-	95	ns
			$V_{CC}=4.5V$	-	-	19	ns
			$V_{CC}=6.0V$	-	-	16	ns

Note:

[1] t_{pd} is the same as t_{PLH} and t_{PHL} .

[2] t_t is the same as t_{THL} and t_{TLH} .

Measurement Points

Type	Input	Output		
	V_M	V_M	V_X	V_Y
SN74LS02	$0.5 \times V_{CC}$	$0.5 \times V_{CC}$	$0.1 \times V_{CC}$	$0.9 \times V_{CC}$

Test Data

Type	Input		Load	Test
	V_I	t_r, t_f	C_L	
SN74LS02	V_{CC}	6.0ns	15pF, 50pF	t_{PLH}, t_{PHL}

Testing Circuit

AC Testing Circuit

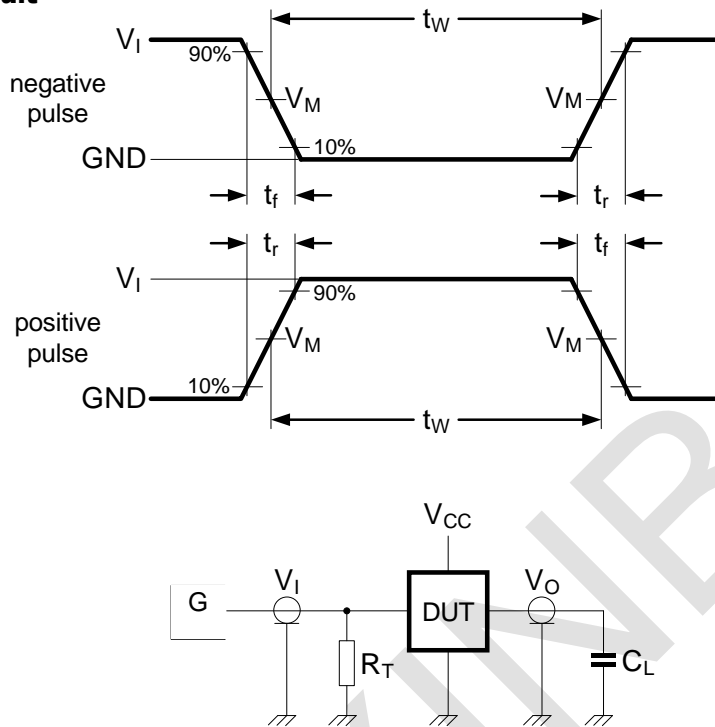

Figure 4. Test circuit for measuring switching times

Definitions for test circuit:

C_L =load capacitance including jig and probe capacitance.

R_T =termination resistance should be equal to the output impedance Z_o of the pulse generator.

AC Testing Waveforms

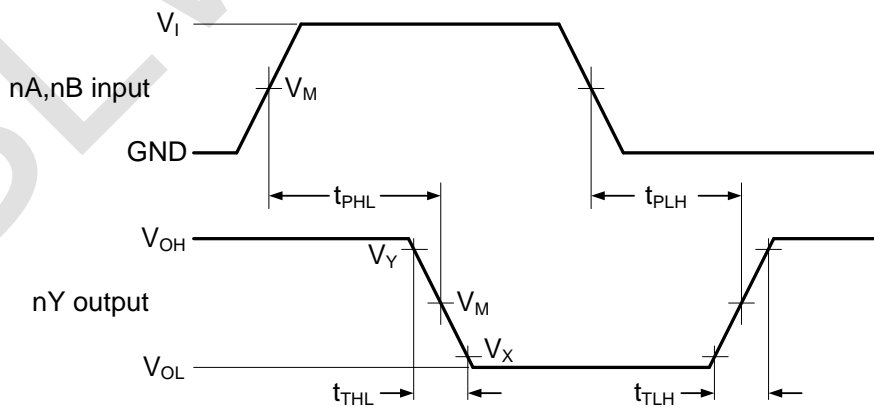
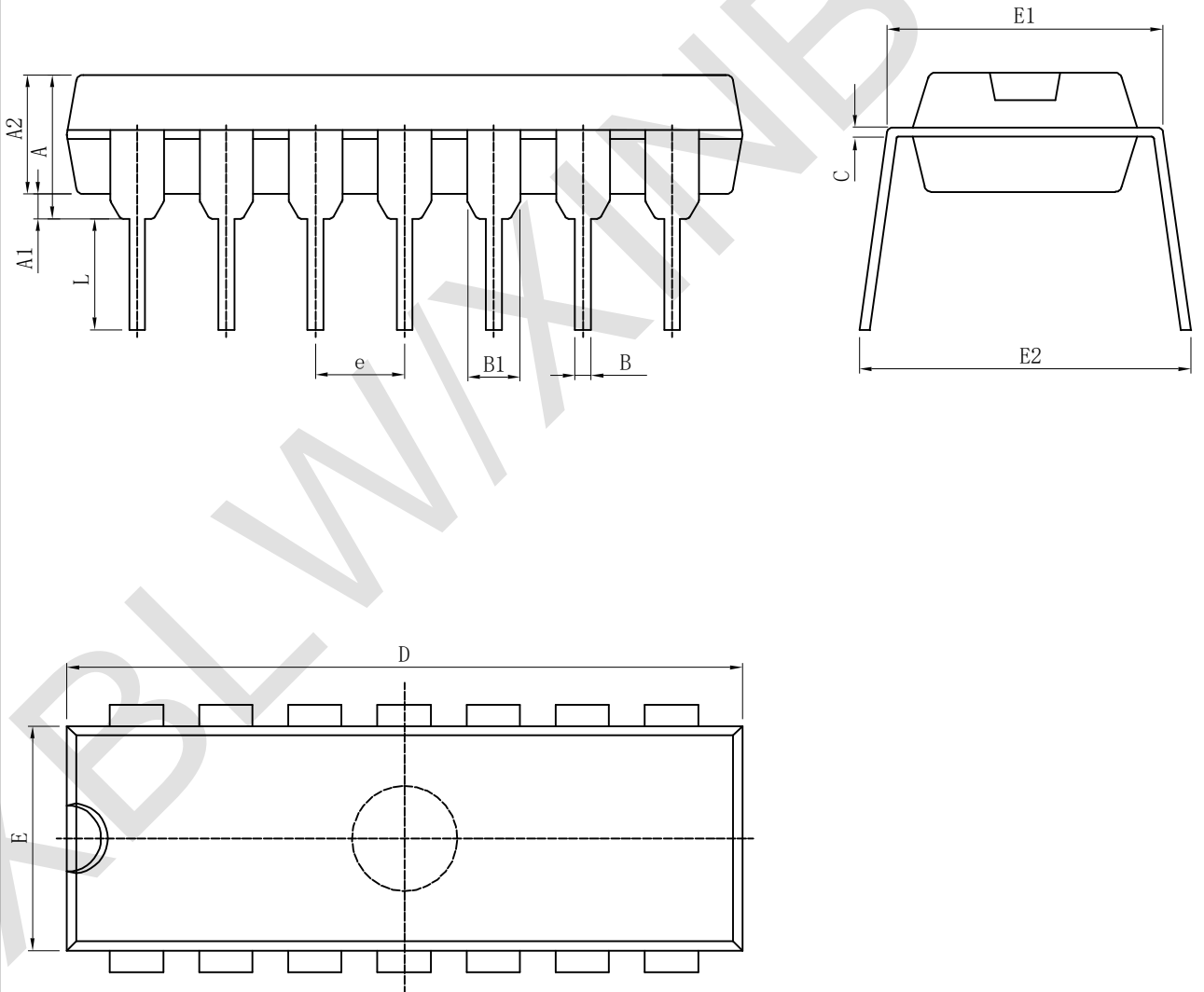

Figure 5. Input to output propagation delays

Package Information

• DIP-14

Size Symbol	Dimensions In Millimeters		Size Symbol	Dimensions In Inches	
	Min (mm)	Max (mm)		Min (in)	Max (in)
A	3.710	4.310	A	0.146	0.170
A1	0.510		A1	0.020	
A2	3.200	3.600	A2	0.126	0.142
B	0.380	0.570	B	0.015	0.022
B1	1.524 (BSC)		B1	0.060 (BSC)	
C	0.204	0.360	C	0.008	0.014
D	18.800	19.200	D	0.740	0.756
E	6.200	6.600	E	0.244	0.260
E1	7.320	7.920	E1	0.288	0.312
e	2.540 (BSC)		e	0.100 (BSC)	
L	3.000	3.600	L	0.118	0.142
E2	8.400	9.000	E2	0.331	0.354



· SOP-14

Size Symbol	Dimensions In Millimeters		Size Symbol	Dimensions In Inches	
	Min(mm)	Max(mm)		Min(in)	Max(in)
A	1.350	1.750	A	0.050	0.068
A1	0.100	0.250	A1	0.004	0.009
A2	1.100	1.650	A2	0.040	0.060
B	0.330	0.510	B	0.010	0.020
C	0.190	0.250	C	0.007	0.009
D	8.550	8.750	D	0.330	0.340
E	3.800	4.000	E	0.150	0.150
e	1.27		e	0.05	
H	5.800	6.200	H	0.220	0.240
h	0.250	0.500	h	0.009	0.020
L	0.400	1.270	L	0.015	0.050
k	8° (max)		k	8° (max)	

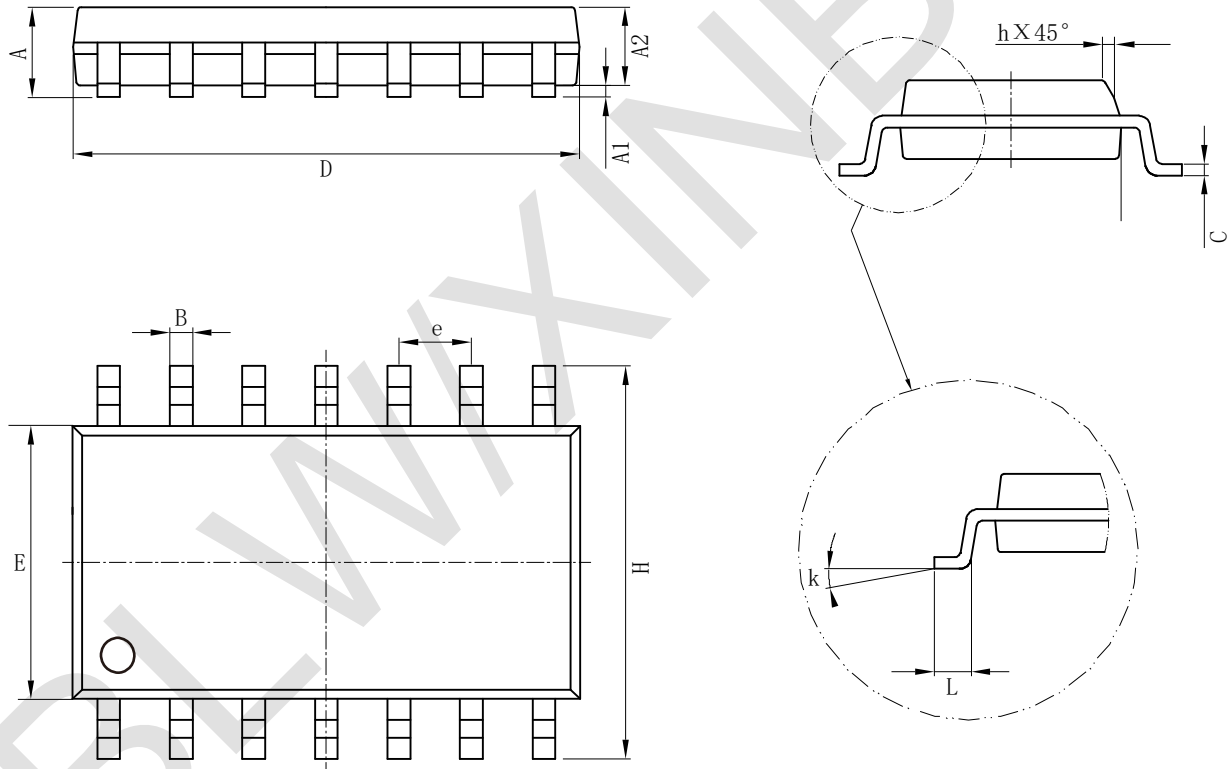

· TSSOP-14

Symbol	Size	Dimensions In Millimeters		Symbol	Size	Dimensions In Inches	
		Min (mm)	Max (mm)			Min (in)	Max (in)
A			1.200	A		0.047	
A1		0.050	0.150	A1		0.002	0.006
A2		0.800	1.050	A2		0.031	0.041
b		0.190	0.300	b		0.007	0.012
c		0.090	0.200	c		0.004	0.0089
D		4.900	5.100	D		0.193	0.201
E		6.200	6.600	E		0.244	0.260
E1		4.300	4.500	E1		0.169	0.176
e		0.65		e		0.0256	
L		0.450	0.750	L		0.018	0.030
L1		1.00		L1		0.039	
k		0°	8°	k		0°	8°

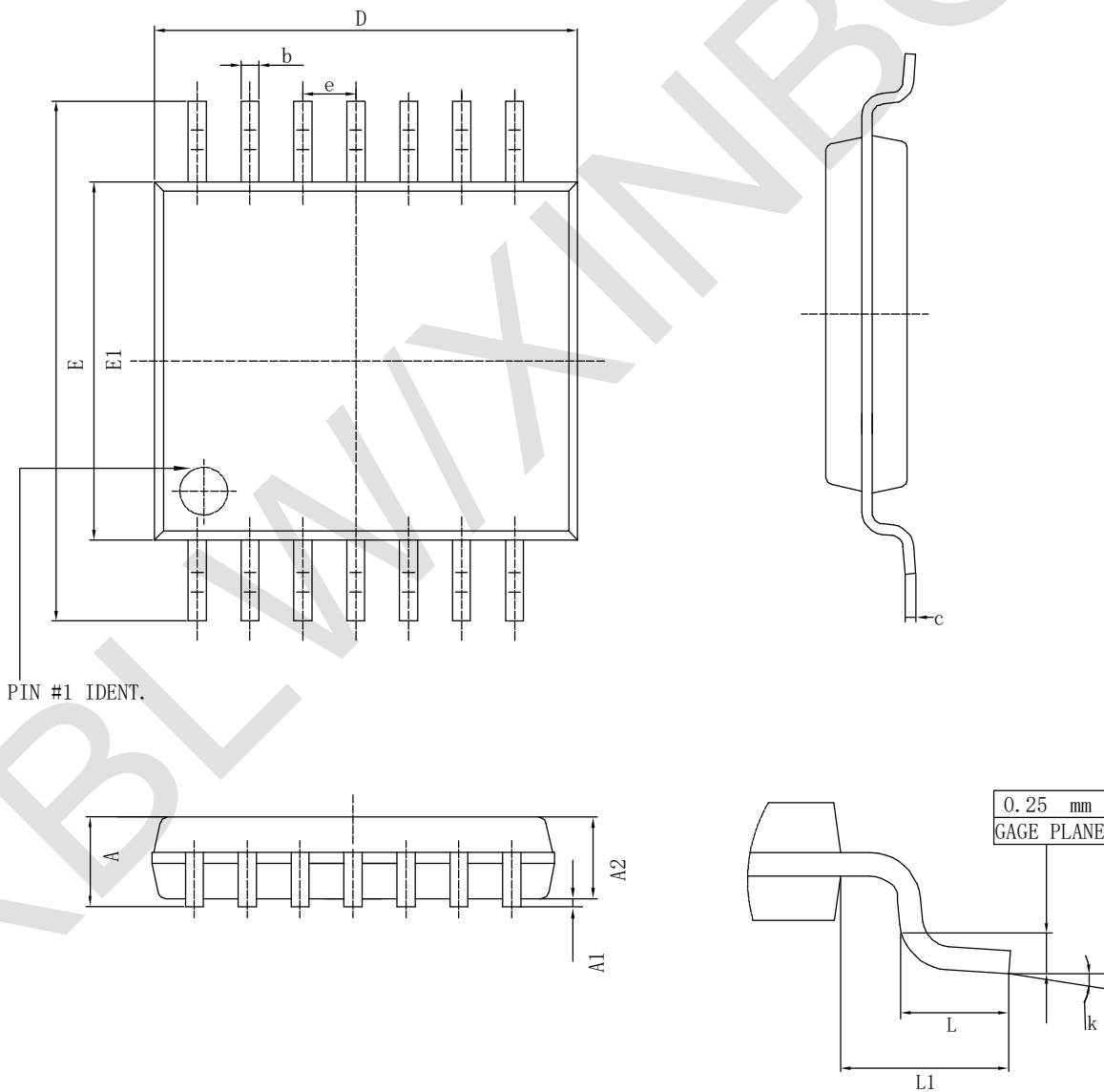

Statement

- XBLW reserves the right to modify the product manual without prior notice! Before placing an order, customers need to confirm whether the obtained information is the latest version and verify the completeness of the relevant information.
- Any semi-guide product is subject to failure or malfunction under specified conditions. It is the buyer's responsibility to comply with safety standards when using XBLW products for system design and whole machine manufacturing. And take the appropriate safety measures to avoid the potential in the risk of loss of personal injury or loss of property situation!
- XBLW product has not been licensed for life support, military and aerospace applications, and therefore XBLW is not responsible for any consequences arising from its use in these areas.
- If any or all XBLW products (including technical data, services) described or contained in this document are subject to any applicable local export control laws and regulations, they may not be exported without an export license from the relevant authorities in accordance with such laws.
- The specifications of any and all XBLW products described or contained in this document specify the performance, characteristics, and functionality of said products in their standalone state, but do not guarantee the performance, characteristics, and functionality of said products installed in Customer's products or equipment. In order to verify symptoms and conditions that cannot be evaluated in a standalone device, the Customer should ultimately evaluate and test the device installed in the Customer's product device.
- XBLW documentation is only allowed to be copied without any alteration of the content and with the relevant authorization. XBLW assumes no responsibility or liability for altered documents.
- XBLW is committed to becoming the preferred semiconductor brand for customers, and XBLW will strive to provide customers with better performance and better quality products.