

Product Specification

XBLW MAX490

High-speed Transceiver

WEB | www.xinboleic.com



Description

The MAX490, which is used for RS-485/RS-422 communication, is a high-speed transceiver with full-duplex communication that includes a driver and a receiver. When the receiver input is open or shorted, it ensures that the receiver output is at a logic high level. If all transmitters attached to the terminated matching bus are disabled (high-impedance), the receiver will output a logic high level.

The MAX490 has a low-rate driver that can reduce EMI and reflections caused by improper terminal matching cables, and achieve error-free data transfer rates up to 2.5Mbps. In addition, the MAX490 has a 1/8 unit load input impedance, and up to 256 transmitters and receivers can be attached to the bus.

Feature:

- Wide power range, full duplex
- Up to 256 transceivers are allowed to be attached on the bus
- Powerful swing rate control function helps to achieve error-free data transmission
- Provide a standard SOP-8 and DIP-8 package

Applications

- Industrial control
- Security system
- Power inverter
- POS machine
- Lighting system

Ordering Information

Product Model	Package Type	Marking	Packing	Packing Qty
XBLW MAX490ESA	SOP-8	MAX490ESA	Tape	2500Pcs/Reel
XBLW MAX490EPA	DIP-8	MAX490EPA	Tube	2000Pcs/Box

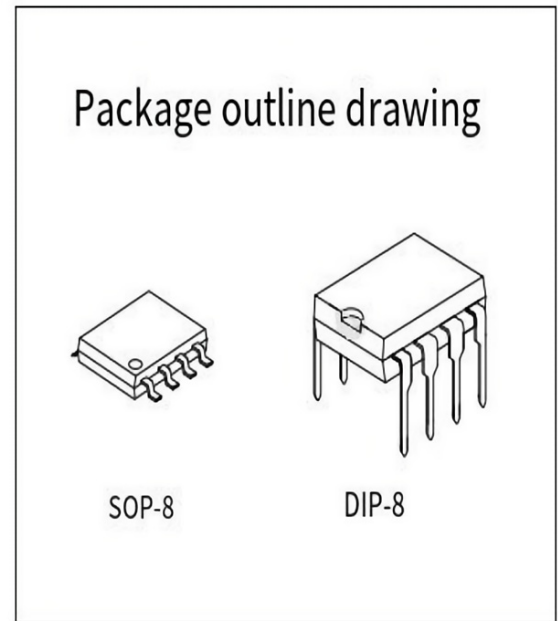

Pin logic diagram and description

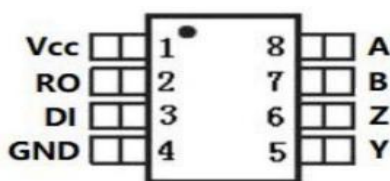

Figure 1: Pin diagram of MAX490

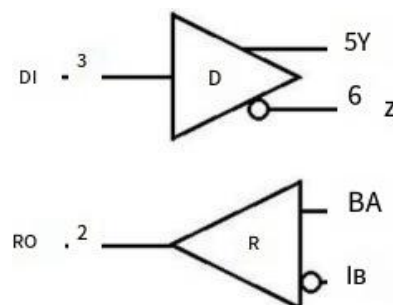

Figure 2: MAX490 logic diagram

Pin Description

lead	Name	Function
Full duplex		
1	VCC	Positive phase supply end : $3.0 \leq VCC \leq 5.5V$
2	RO	Receiver output. If $A-B \geq -50mV$, RO output is high; If $A-B \leq -200mV$, RO output is low
3	DI	Drive input. The low level on the DI forces the same phase output to be low level and the reverse phase output to be high level. Similarly, a high level on the DI will force the in-phase output to be high and the anti-phase output to be low
4	GND	Ground
5	Y	Drive in-phase output end
6	Z	Drive inverting output end
7	B	Receiver inverting input
8	A	Receiver in-phase input

Absolute maximum rating

Project	Symbol	Parameter	unit
Supply voltage	VCC	+ 7	V
Drive input voltage	DI	-0.3 to VCC+0.3	V
Drive output voltage	Y, Z	-8 to + 13	V
Receiver input voltage	A, B	-8 to + 13	V
Receiver output voltage	RO	-0.3 ~ VCC+0.3	V
Continuous power consumption	SOP8	471	mW
Operating temperature range		0 ~ +70	°C
Storage temperature		-65 ~ +150	°C
Welding temperature, 10S	TLEAD	245	°C

Note:

Any application attempt above the absolute maximum rating has the potential to cause permanent damage to the product, and the absolute maximum rating does not mean that the product will function properly under conditions other than the calibrated electrical characteristics.

Dc electrical characteristics (unless otherwise stated, $V_{CC}=+5V\pm 5$, $T_A=T_{MIN} \sim T_{MAX}$, typical values at $V_{CC}=+5V$, $T_A= 25^{\circ}C$) (Note 1)

Parameter	Symbol	Test condition	MIN	TYP	MAX	Units
Drives						
Supply voltage	VCC		3.0		5.5	V
Differential driver output (no load)	V _{OD1}	Figure 4	1.5		5	V
Differential driver output	V _{OD2}	Figure 4, R=50Ω(RS-422)	2.0		5	V
		Figure 4, R=27Ω(RS-485)	1.5		5	
Amplitude change in differential output voltage (Note 2)	ΔV _{OD}	Figure 4, R=50Ω or R=27Ω			0.2	V
Drive common mode output voltage	V _{OC}	Figure 4, R=50Ω or R=27Ω	1		3	V
Amplitude change in common mode voltage (Note 2)	ΔV _{OC}	Figure 4, R=50Ω or R=27Ω			0.2	V
Input high voltage	V _{IH1}	DE,DI,,RE	2.0			V
Input low voltage	V _{IL1}	DE,DI,,RE			0.8	V
DI input lag	V _{HYS}			100		mV
Input current (A,B) full duplex	I _{IN4}	DE=GND VCC=GND or 5.25V	VIN= 12V		125	μA
			VIN=-7V	- 75		
Drive short circuit output current	I _{OSD}	-7V ≦ VOUT ≦ VCC	- 250			mA
		0V ≦ VOUT ≦ 12V			250	
		0V ≦ VOUT ≦ VCC	±25			
Receiver						
Receiver differential threshold voltage	V _{TH}	-7V ≦ VCM ≦ 12V	- 200	- 110	- 50	mV
Receiver input lag	Δ V _{TH}			30		mV
Receiver output high voltage	V _{OH}	IO=-4mA,VID=-50mV	V _{CC} -1.5			V
Receiver output low voltage	V _{OL}	IO=4mA,VID=-200mV			0.4	V
Three state output current at receiver end	I _{OZR}	0.4V ≦ VO ≦ 2.4V			±1	μA
Receiver input impedance	R _{IN}	-7V ≦ VCM ≦ 12V	96			KΩ
Receiver output short-circuit current	I _{OSR}	0V ≦ VRO ≦ VCC	±7		±95	mA
Supply current						
Static working current	I _{CC}	No load, DI=0 or VCC		270	600	μA
ESD electrostatic protection						
ESD HBM		ESD HBM			3000	V

Note 1: All current into the device is positive and all current out of the device is negative; All voltages, if without exception, are stated to be correct.

Note 2: When the DI input changes state, ΔV_{OD} and ΔV_{OC} are V_{OD} and V_{OC} changes, respectively.

Note 3: Maximum current is used for peak current only before feedback current limit, minimum current is used during current limit.

Conversion characteristics (If not stated otherwise, VCC = + 5V ± 5 %, TA = TMIN ~ TMAX, typical value at VCC = + 5V, TA=25°C)

Parameter	Symbol	Condition	MIN	TYP	MAX	Units
Drive input to output	T _{DPLH}	Figures 5 and 6, R _{DIFF} =54Ω CL1=CL2=100pF	250	720	900	ns
	T _{DPHL}		250	720	900	
Drive output t _{DPLH} - t _{DPHL}	T _{DHKEW}	Figures 5 and 6, R _{DIFF} =54Ω CL1=CL2=100pF		- 3	±100	ns
Drive up or down time	t _{DR} , t _{DF}	Figures 5 and 6, R _{DIFF} =54Ω CL1=CL2=100pF	200	530	750	ns
Maximum data rate	F _{MAX}				2.5	M
Receiver input to output	T _{RPLH}	Figures 7 and 8, rise and fall times, VID ≥ 2.0V VID ≤ 15ns		127	200	ns
	T _{RPHL}					
Differential receiver t _{DPLH} - t _{DPHL}	T _{RSKD}	FIG. 7 and 8, rise and fall times of VID ≥ 2.0V VID ≤ 15ns		3	±30	ns

Feature Sheet

Send		
Type	Output	
DI	B	A
1	0	1
0	1	0

Receive	
Input	Output
A-B	RO
P - 0.05 - V	1
0.2 V or less	0
Open/shorted	1

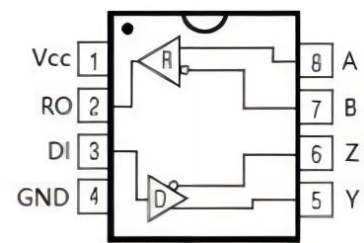

DIP/SOP

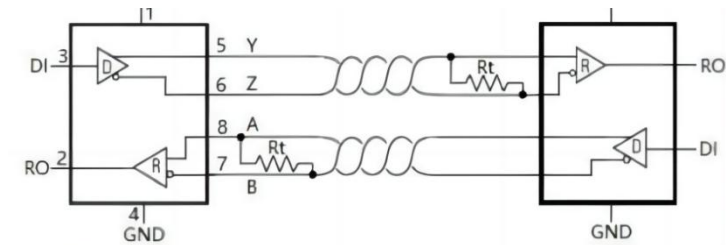

Figure 3: MAX490 typical full duplex application circuit

Expatriate

The MAX490 high-speed transceiver for RS-485 / RS-422 communication contains a drive and receiver. It has a failure protection circuit to ensure that the receiver output logic high level when the receiver input is open or short circuit. If all senders attached to the terminal match bus are disabled (high resistance), the receiver will output the logic high level. MAX490 With a low pendulum rate drive, it can reduce EMI and reflection due to improper cable termination, enabling error-free data transmission of up to 2 . 5 Mbps. MAX490 Is a full-duplex transceiver.

Receiver input filtering

When working in the MAX490 in 2 . 5 Mbps mode ,

its receiver also includes the input filtering function in addition to having the input lag.

This filtering function improves the noise suppression ability of differential signals that rise and fall slowly.

The filter increases the receiver transmission delay by 25%.

Fail protect

The MAX490 ensures that the receiver output logic high level when the receiver input is short circuit or open circuit, or when all drives attached to the terminal matching transmission line are disabled. This was achieved by setting the receiver input threshold to -50 mV and -200 mV, respectively. If the differential receiver input voltage (A-B) is greater than or equal to -50 mV, RO is logic high level; if the voltage (A-B) is less than or equal to -200 mV, RO is logic low level.

When all the transmitters attached to the terminal matching bus are disabled, the receiver differential input voltage is pulled to 0V through the terminal resistance. According to the receiver threshold, a logical high level with a 50 mV minimum noise tolerance can be achieved. Unlike previous failure protection devices, the -50 mV to -200 mV threshold voltage meets the EIA / TIA-485 standard of ± 200 mV

256 transceivers are attached to the bus

The standard RS-485 receiver has an input impedance of 12 k Ω (1 unit load), and the standard drive drives up to 32 unit loads. MAX490 The receiver of the transceiver has a 1 / 8 unit of load input impedance (96 k Ω), allowing up to 256 transceivers to be attached in parallel to the same communication bus. These devices may be combined arbitrarily or with other RS-485 transceivers and may be attached to the same bus as long as the total load does not exceed 32 unit loads.

Reduce EMI and reflection

MAX490 Low pendulum rate drive can reduce the EMI, and reduce the reflection caused by inappropriate terminal matching cable, figure 9 shows the high frequency harmonic element in amplitude is lower than the general case, the drive along the time related to the length of the terminal, the following equation represents the relationship: $\text{Length} = t_{RISE} / (10 \times 1.5 \text{ ns/ft})$, t_{RISE} is the drive along the time.

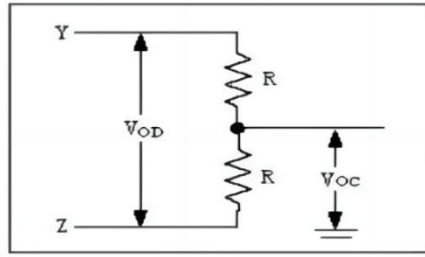

Figure 4: Drive DC test load

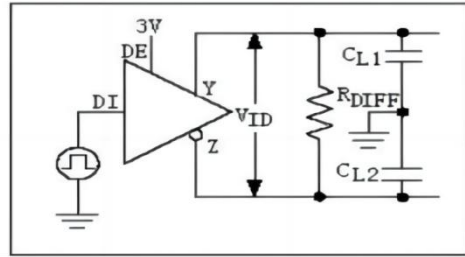

Figure 5: Drive timing test circuit

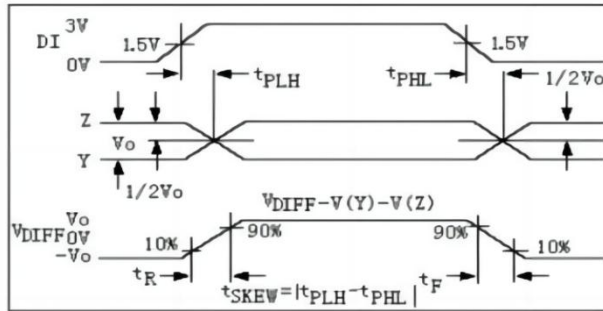

Figure 6: Driver propagation delay

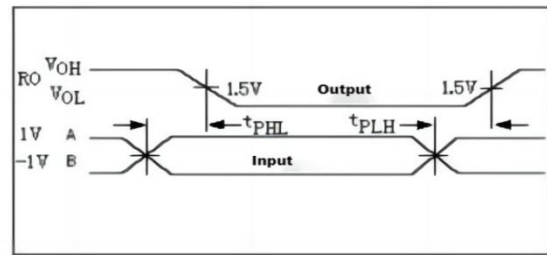

Figure 7: Receiver propagation delay

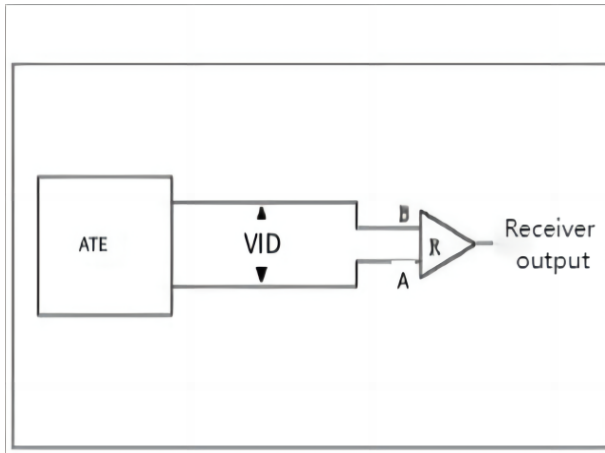

Figure 8: Receiver propagation delay test circuit

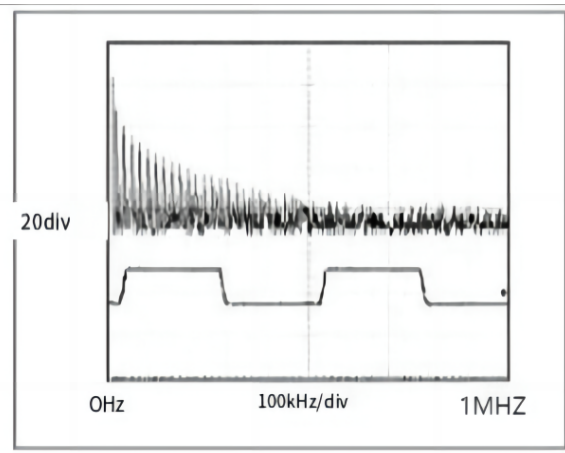

Figure 9: MAX490 driver when transmitting 20kHz signal

FFT diagram of output waveform

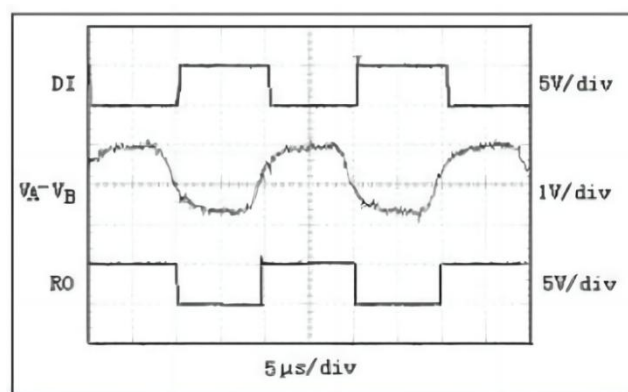
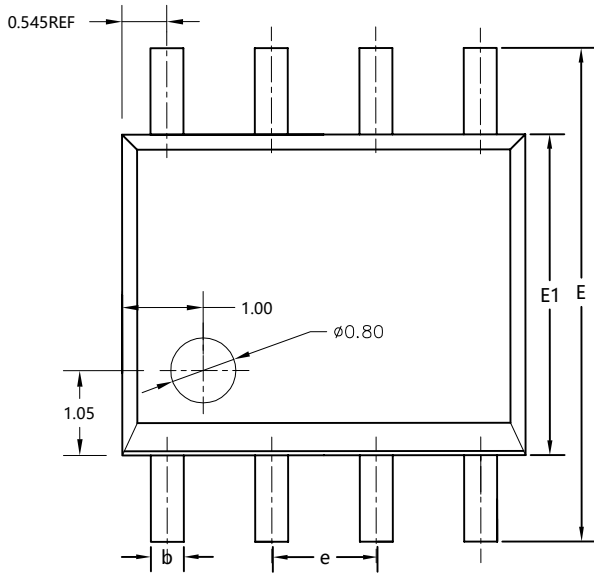
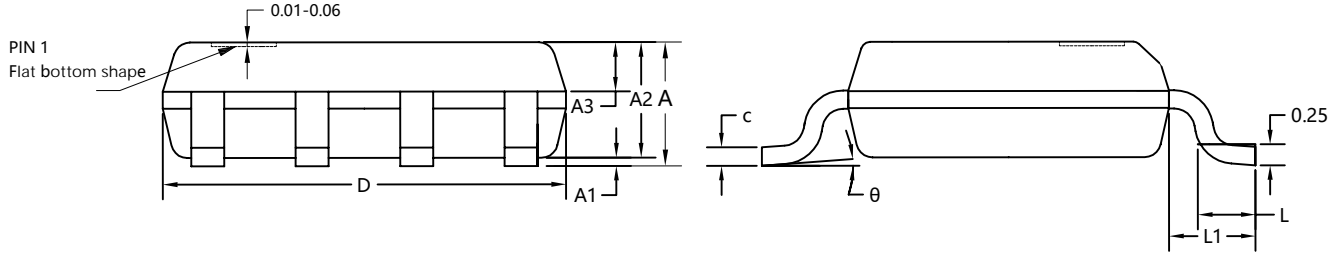

Figure 10: Driving 4000 ft cable at 50kHz MAX490 system differential voltage linear transponder

Package Outline Dimensions

SOP-8



SYMBOL	MILLIMETER		
	MIN	NOM	MAX
A	1.55	1.65	1.75
A1	0.10	0.15	0.20
A2	1.35	1.45	1.55
A3	0.60	0.70	0.80
b	0.30	0.40	0.50
c	0.17	0.20	0.25
D	4.80	4.90	5.00
E	5.80	6.00	6.20
E1	3.80	3.90	4.00
e	1.27BSC		
L	0.50	0.60	0.70
L1	1.05REF		
θ	0°	4°	8°

DIP-8

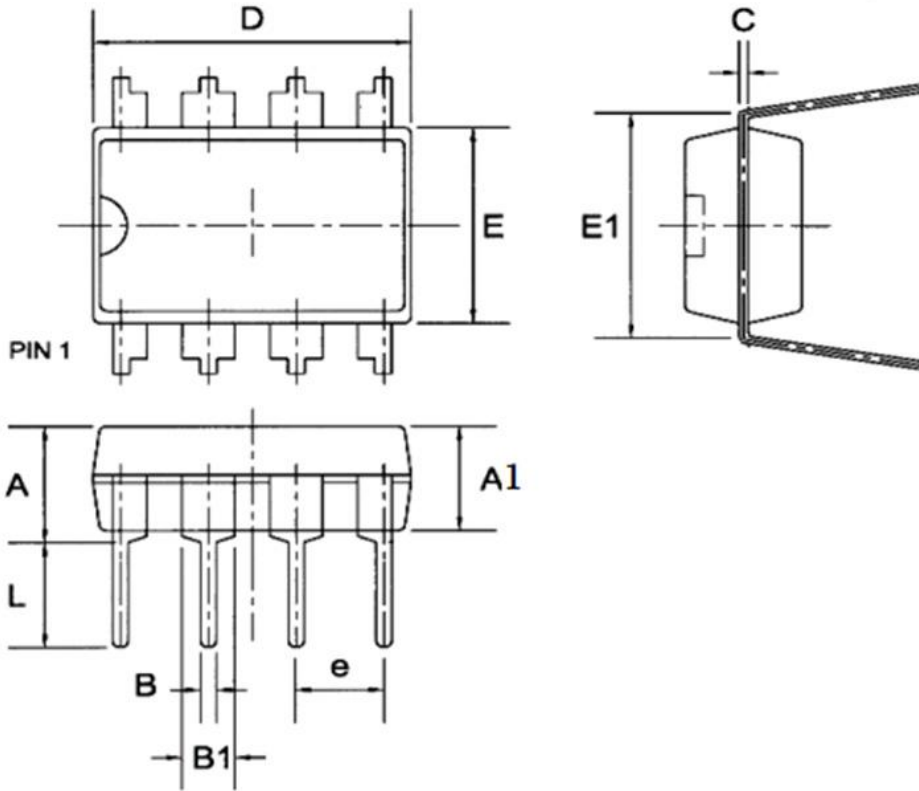

Symbol	Dimensions in Millimeters		
	Min	Nom	Max
A	--	--	4.31
A1	3.15	3.30	3.65
B	0.38	0.46	0.51
B1	1.27	1.55	1.77
C	0.20	0.25	0.30
D	8.95	9.40	9.45
E	6.15	6.20	6.65
E1	--	7.60	--
e	--	2.54	--
L	3.00	3.30	3.60

Statement:

- XBLW reserves the right to modify the product manual without prior notice! Before placing an order, customers need to confirm whether the obtained information is the latest version and verify the completeness of the relevant information.
- Any semi-guide product is subject to failure or malfunction under specified conditions. It is the buyer's responsibility to comply with safety standards when using XBLW products for system design and whole machine manufacturing. And take the appropriate safety measures to avoid the potential in the risk of loss of personal injury or loss of property situation!
- XBLW products are not licensed for life support, military, aerospace and other applications, and XBLW will not be responsible for the consequences of the use of products in these fields.
- If any or all XBLW products (including technical data, services) described or contained in this document are subject to any applicable local export control laws and regulations, they may not be exported without an export license from the relevant authorities in accordance with such laws.
- The specifications of any and all XBLW products described or contained in this document specify the performance, characteristics, and functionality of said products in their standalone state, but do not guarantee the performance, characteristics, and functionality of said products installed in Customer's products or equipment. In order to verify symptoms and conditions that cannot be evaluated in a standalone device, the Customer should ultimately evaluate and test the device installed in the Customer's product device.
- XBLW documentation is only allowed to be copied without any alteration of the content and with the relevant authorization. XBLW assumes no responsibility or liability for altered documents.
- XBLW is committed to becoming the preferred semiconductor brand for customers, and XBLW will strive to provide customers with better performance and better quality products.

单击下面可查看定价，库存，交付和生命周期等信息

[>>XBLW\(芯伯乐\)](#)