

芯伯乐®  
X I N B O L E

# Product Specification

XBLW XBL4015

5A 180KHz 40V PWM Buck DC/DC Converter

WEB | [www.xinboleic.com](http://www.xinboleic.com)



## Descriptions

The XBL4015 is a 180 KHz fixed frequency PWM buck (step-down) DC/DC converter, capable of driving a 5A load with high efficiency, low ripple and excellent line and load regulation. Requiring a minimum number of external components, the regulator is simple to use and include internal frequency compensation and a fixed-frequency oscillator.

The PWM control circuit is able to adjust the duty ratio linearly from 0 to 100%. An over current protection function is built inside. When short protection function happens, the operation frequency will be reduced from 180KHz to 48KHz. An internal compensation block is built in to minimize external component count.

## Features

- Wide 4.5V to 36V Input Voltage Range
- Output Adjustable from 1.25V to 32V
- Maximum Duty Cycle 100%
- Minimum Drop Out 0.3V
- Fixed 180KHz Switching Frequency
- 5A Constant Output Current Capability
- Internal Optimize Power MOSFET
- High efficiency up to 96%
- VC has TTL function
- Excellent line and load regulation
- Built in thermal shutdown function
- Built in current limit function
- Built in output short protection function
- Available in TO-263-5L package

## Applications

- Portable DVD
- LCD Monitor / TV
- Battery Charger
- ADSL Modem
- Telecom / Networking Equipment

## Ordering Information

Product Model	Package Type	Marking	Packing	Packing Qty
XBLW XBL4015E1TB	TO-263-5L	XBL4015E1	Tube	1000Pcs/Box
XBLW XBL4015E1DTR	TO-265-5L	XBL4015E1	Tape	800Pcs/Reel

E1: Equipped with heat sink.

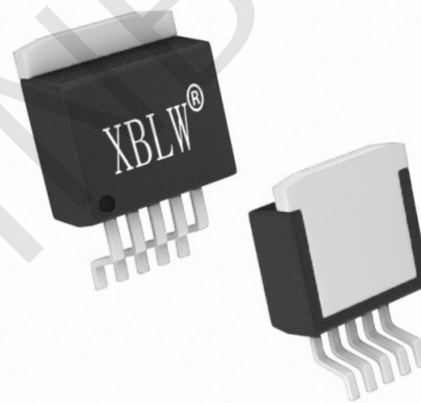

TO-263-5L

## Pin Configurations

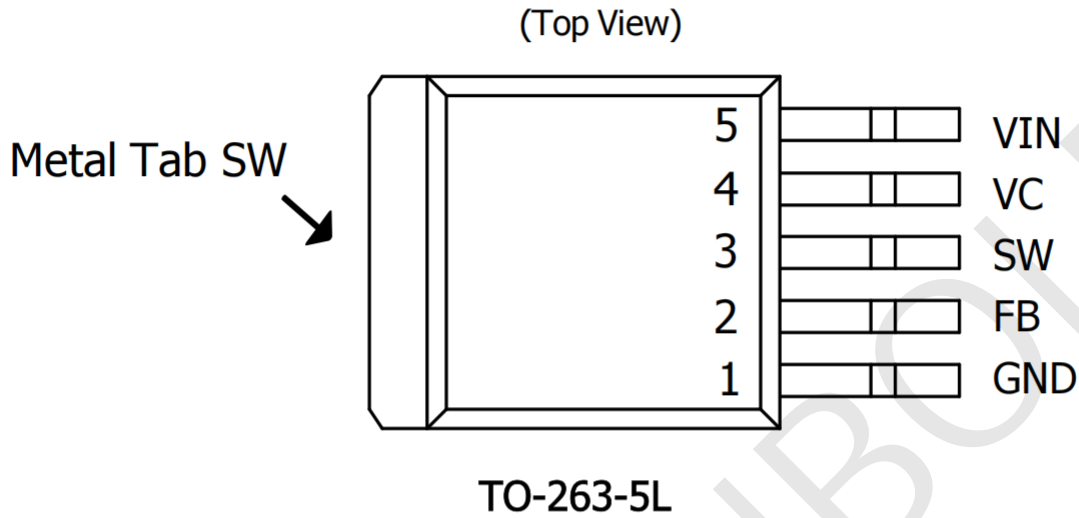

## Pin Description

Pin Number	Pin Name	Description
1	GND	Ground Pin. Care must be taken in layout. This pin should be placed outside of the Schottky Diode to output capacitor ground path to prevent switching current spikes from inducing voltage noise into XBL4015.
2	FB	Feedback Pin (FB). Through an external resistor divider network, FB senses the output voltage and regulates it. The feedback threshold voltage is 1.25V.
3	SW	Power Switch Output Pin (SW). SW is the switch node that supplies power to the output.
4	VC	Internal Voltage Regulator Bypass Capacity. In typical system application, The VC pin connect a 1uF capacity to VIN. VC pin has TTL function, see Figure 6.
5	VIN	Supply Voltage Input Pin. XBL4015 operates from a 4.5V to 36V DC voltage. Bypass Vin to GND with a suitably large capacitor to eliminate noise on the input.
Tab	SW	Power Switch Output Pin (SW). SW is the switch node that supplies power to the output.

## Function Block

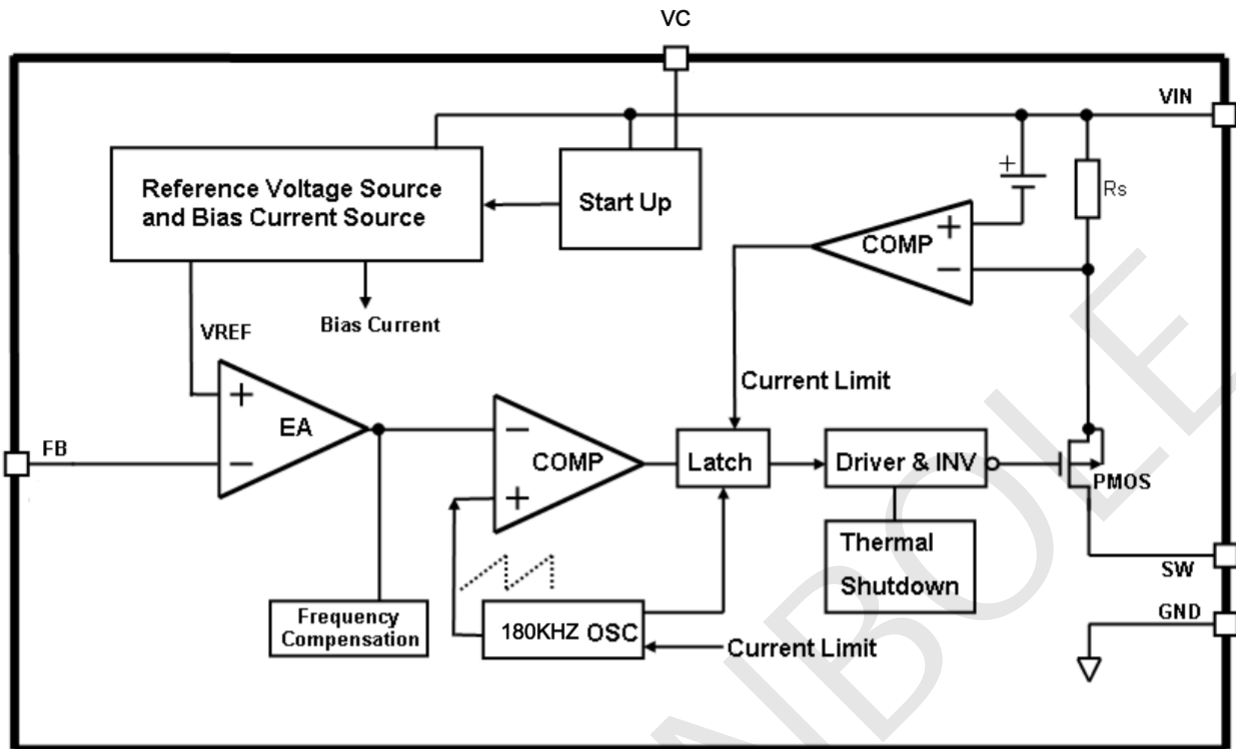

## Absolute Maximum Ratings

**Note:** Stresses greater than those listed under Maximum Ratings may cause permanent damage to the device. This is a stress rating only and functional operation of the device at these or any other conditions above those indicated in the operation is not implied. Exposure to absolute maximum rating conditions for extended periods may affect reliability.

Parameter	Symbol	Value	Unit
Input Voltage	$V_{IN}$	-0.3 to 40	V
Feedback Pin Voltage	$V_{FB}$	-0.3 to $V_{IN}$	V
Enable Pin Voltage	$V_{EN}$	-0.3 to $V_{IN}$	V
Switch Pin Voltage	$V_{SW}$	-0.3 to $V_{IN}$	V
Power Dissipation	$P_D$	Internally limited	mW
Operating Junction Temperature	$T_J$	-40 to 125	°C
Storage Temperature	$T_{STG}$	-65 to 150	°C
Lead Temperature (Soldering, 10 sec)	$T_{LEAD}$	260	°C
ESD (HBM)		2000	V
MSL		Level 3	
Thermal Resistance-Junction to Ambient	$R_{\theta JA}$	85	°C / W
Thermal Resistance-Junction to Case	$R_{\theta JC}$	45	°C / W

## Typical Application Circuit

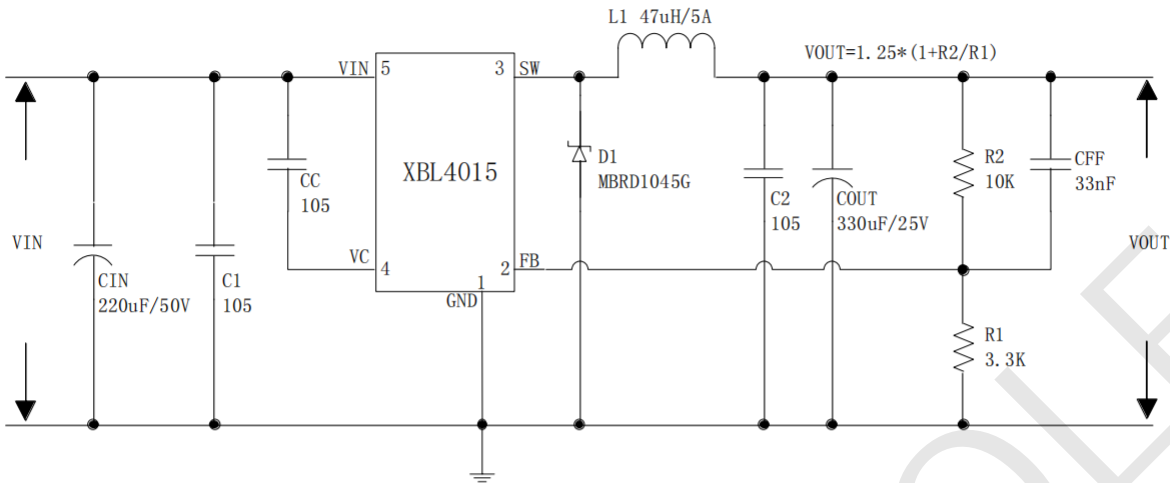

Figure 1 . XBL4015 Typical Application Circuit (VIN=4.5V~36V, VOUT=5V/5A)

## Electrical Characteristics

Ta=25°C; unless otherwise specified.

Parameter	Symbol	Test Condition	Min.	Typ.	Max.	Unit
<b>System parameters test circuit figure 1</b>						
VFB	Feedback Voltage	Vin = 8V to 40V, Vout=5V Iload=0.5A to 5A	1.225	1.25	1.275	V
Efficiency	$\eta$	Vin=12V ,Vout=5V Iout=5A	-	87	-	%
Efficiency	$\eta$	Vin=24V ,Vout=12V Iout=4A	-	93	-	%

## Electrical Characteristics (DC Parameters)

Vin = 12V, GND=0V, Vin & GND parallel connect a 220uF/50V capacitor; Iout=500mA,  
Ta = 25°C; the others floating unless otherwise specified.

Parameters	Symbol	Test Condition	Min.	Typ.	Max.	Unit
Input operation voltage	Vin		4.5		36	V
Quiescent Supply Current	Iq	VFB =5V		2.8	5	mA
Oscillator Frequency	Fosc		144	180	216	KHz
Output Short Frequency	Fosp			48		KHz
Switch Current Limit	IL	VFB =0		8		A
Max. Duty Cycle	D <sub>MAX</sub>	VFB=0V		100		%
Output Power PMOS	Rdson	VFB=0V, Vin=12V, ISW=5A		60	80	mohm

**Typical System Application (VOUT=5V/5A)**

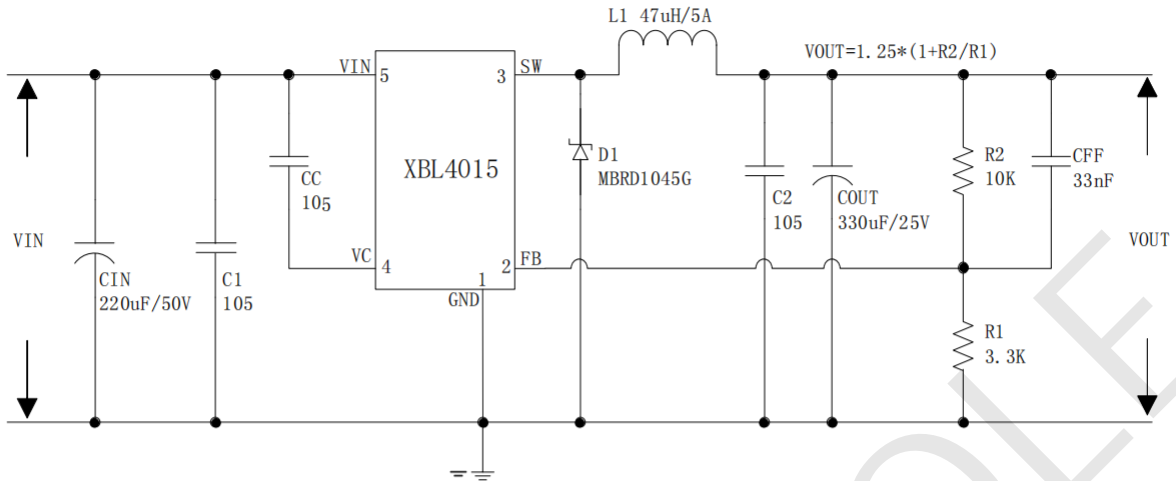

Figure 2 . XBL4015 System Parameters Test Circuit (VIN=8V~36V, VOUT=5V/5A)

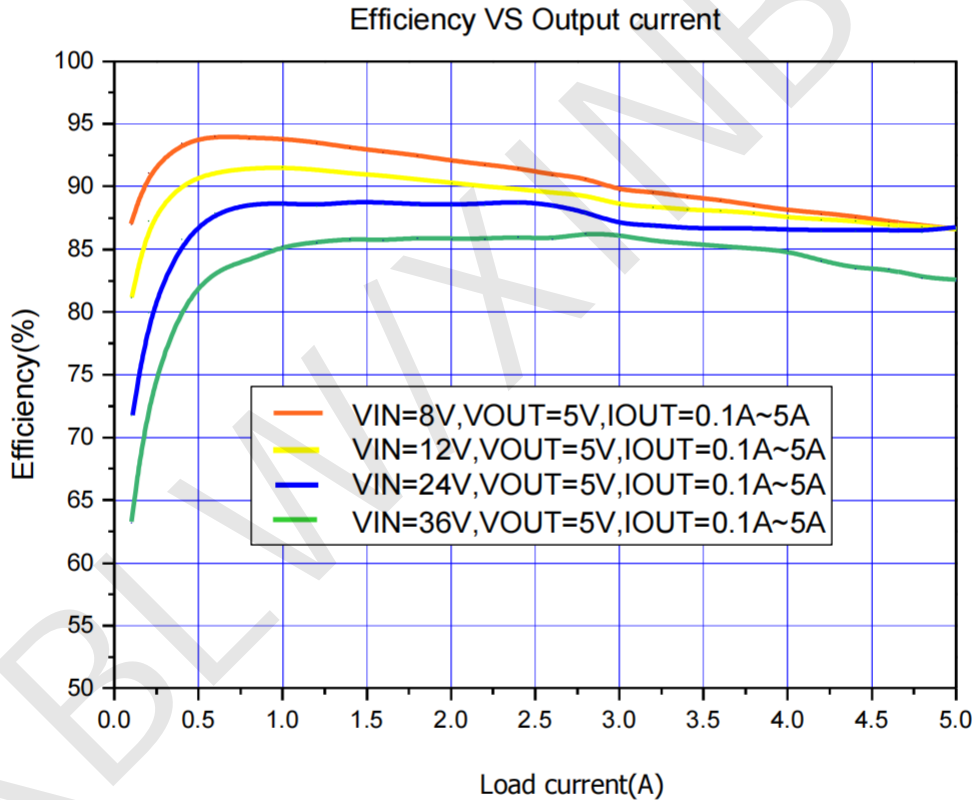

Figure 3. XBL4015 System Efficiency Curve

Typical System Application (VOUT=12V/4A)

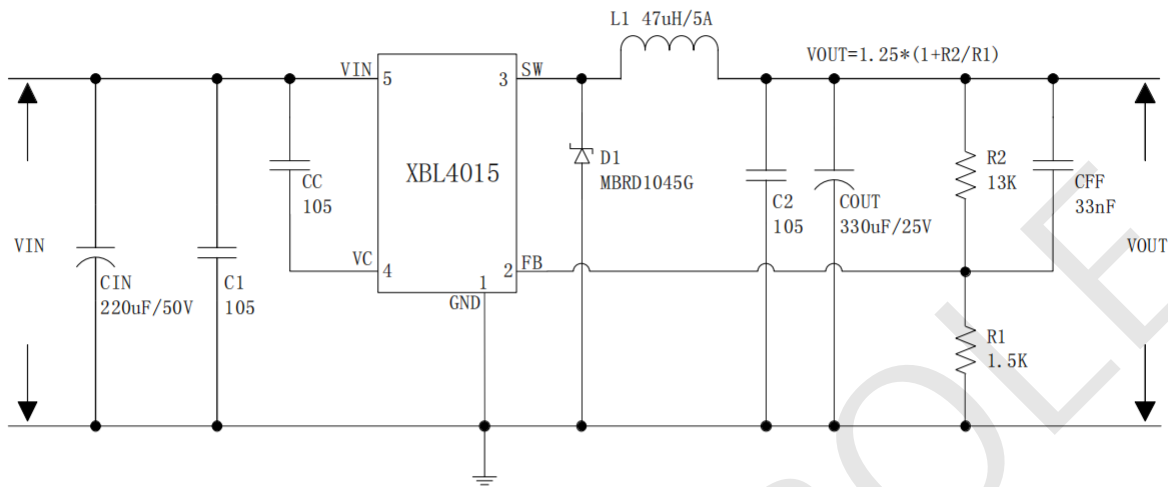

Figure 4 . XBL4015 System Parameters Test Circuit (VIN=15V~36V, VOUT=12V/4A)

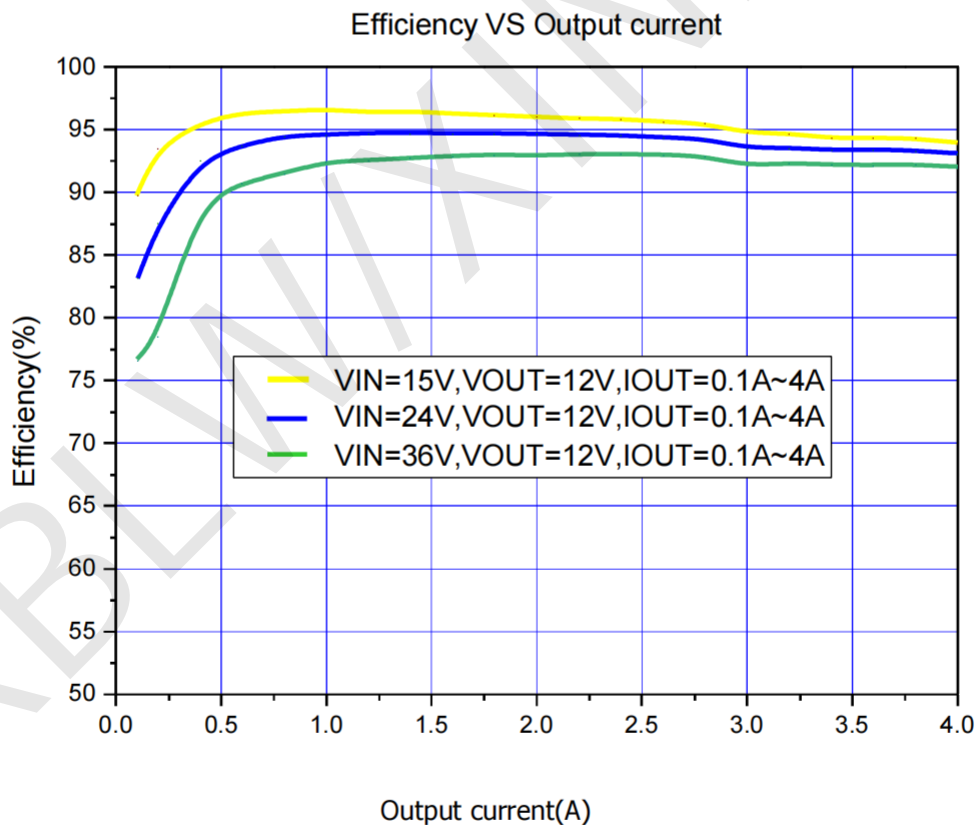

Figure 5 . XBL4015 System Efficiency Curve

### Typical System Application (VC shutdown function)

Logic level signals shutdown function can be used in typical system application without external components. When the VC high voltage lower than 0.8V, the converter will shutdown; when the VC voltage above 1.2V or float, the converter will turn on.

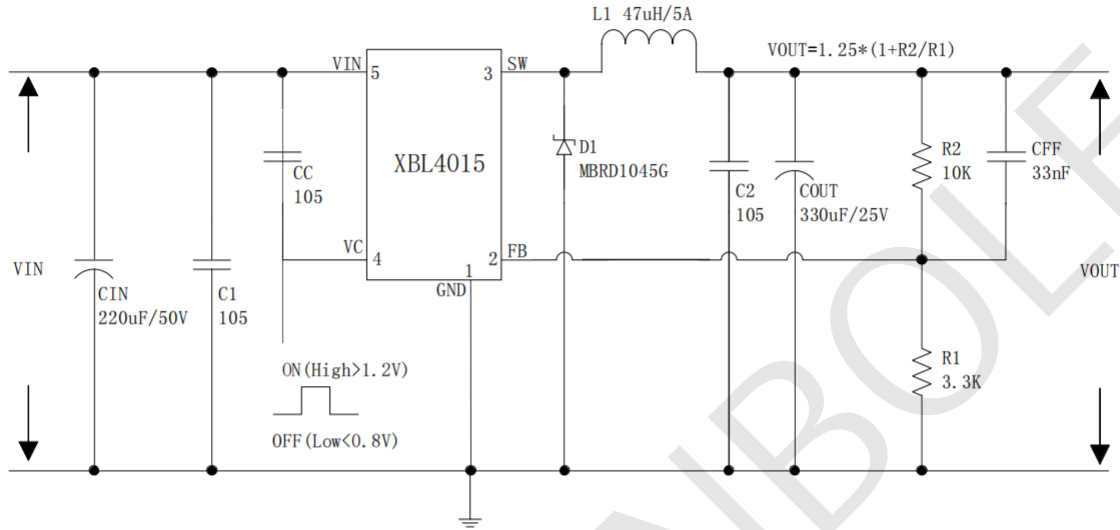

Figure 6 . XBL4015 Typical Application Circuit



**Package Information**

· T0-263-5L

Symbol	Dimensions In Millimeters		Symbol	Dimensions In Inches	
	Min (mm)	Max (mm)		Min (in)	Max (in)
A	1.170	1.370	A	0.046	0.054
A1	4.470	4.670	A1	0.176	0.184
A2	0.310	0.530	A2	0.012	0.021
B1	2.340	2.740	B1	0.092	0.108
C	5.080 (REF)		C	0.200 (REF)	
D	1.170	1.370	D	0.046	0.054
D1	8.500	8.900	D1	0.335	0.350
D2	14.55	15.55	D2	0.572	0.612
E	0.660	0.860	E	0.025	0.034
E1	10.01	10.31	E1	0.394	0.406
e	1.700 (BSC)		e	0.067 (BSC)	

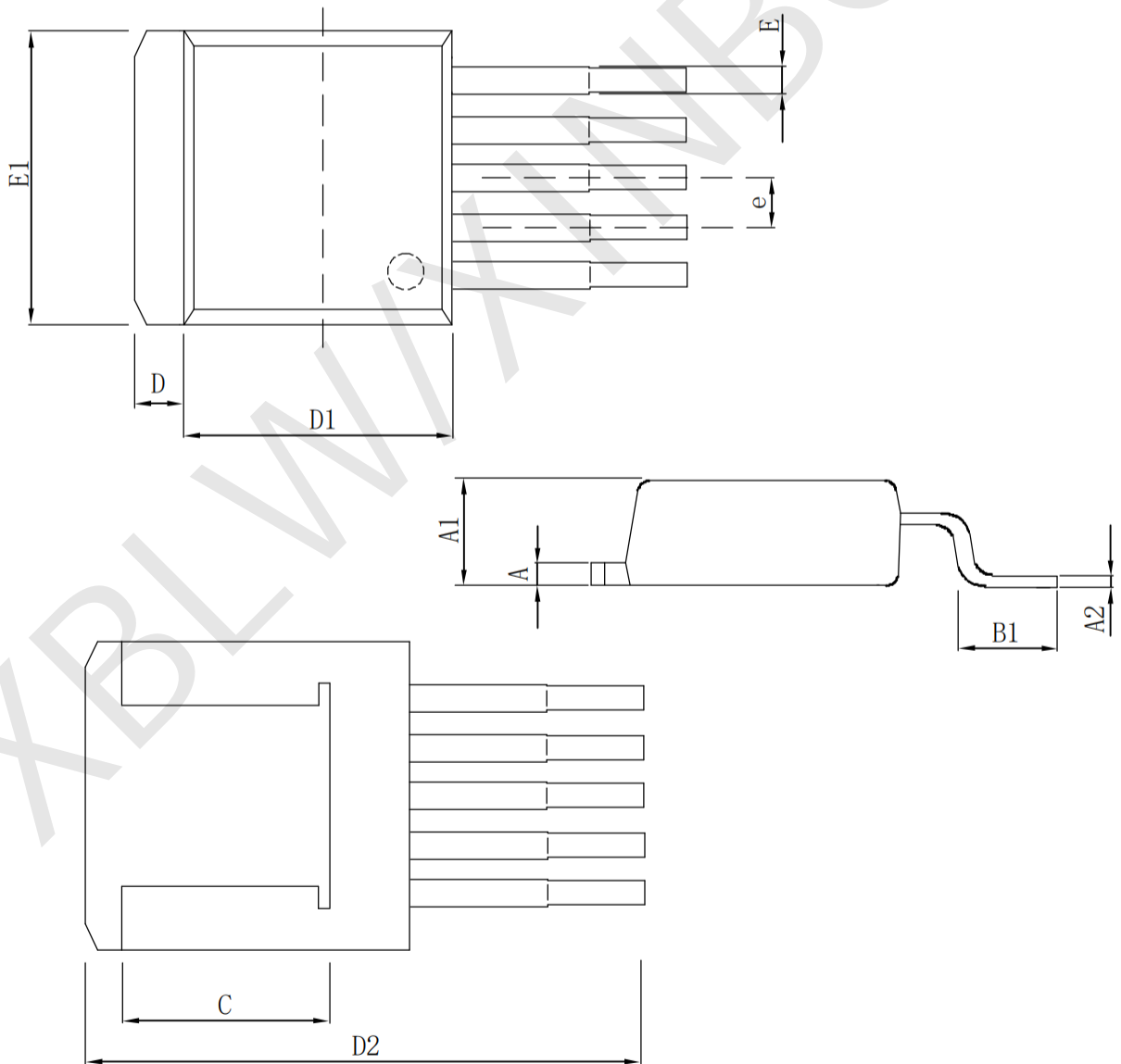

## Statement:

- XBLW reserves the right to modify the product manual without prior notice! Before placing an order, customers need to confirm whether the obtained information is the latest version and verify the completeness of the relevant information.
- Any semi-guide product is subject to failure or malfunction under specified conditions. It is the buyer's responsibility to comply with safety standards when using XBLW products for system design and whole machine manufacturing. And take the appropriate safety measures to avoid the potential in the risk of loss of personal injury or loss of property situation!
- XBLW products have not been licensed for life support, military, and aerospace applications, and therefore XBLW is not responsible for any consequences arising from the use of this product in these areas.
- If any or all XBLW products (including technical data, services) described or contained in this document are subject to any applicable local export control laws and regulations, they may not be exported without an export license from the relevant authorities in accordance with such laws.
- The specifications of any and all XBLW products described or contained in this document specify the performance, characteristics, and functionality of said products in their standalone state, but do not guarantee the performance, characteristics, and functionality of said products installed in Customer's products or equipment. In order to verify symptoms and conditions that cannot be evaluated in a standalone device, the Customer should ultimately evaluate and test the device installed in the Customer's product device.
- XBLW documentation is only allowed to be copied without any alteration of the content and with the relevant authorization. XBLW assumes no responsibility or liability for altered documents.
- XBLW is committed to becoming the preferred semiconductor brand for customers, and XBLW will strive to provide customers with better performance and better quality products.

单击下面可查看定价，库存，交付和生命周期等信息

[>>XBLW\(芯伯乐\)](#)