

General Description

The XBLW LM317L is an adjustable 3-terminal positive voltage regulator, designed to supply 100mA of output current with voltage adjustable from 1.25V~37V。

Features

- Typical 1% Output Voltage Tolerance
- Output Voltage Adjustable from 1.25V~37V
- Output Current in Excess of 100mA
- Internal Short Circuit Protection
- Internal Over Temperature Protection
- Output Transistor Safe Area Compensation

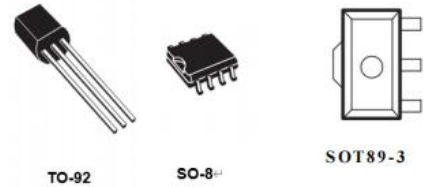

Ordering Information

Product Model	Package Type	Marking	Packing	Packing Qty
XBLW LM317LG	TO-92	317L	Bag	1000PCS/Bag
XBLW LM317LSDTR	SOP-8	LM317L	Tape	2500PCS/Reel
XBLW LM317LTDTR	SOT-89-3	LM317L	Tape	4000PCS/Reel

Application

- PC Motherboard
- LCD Monitor
- Graphic Card
- DVD Player
- Network Interface Card/ Switch
- Telecom Equipment
- Printer and other Peripheral Equipment

Block Diagram

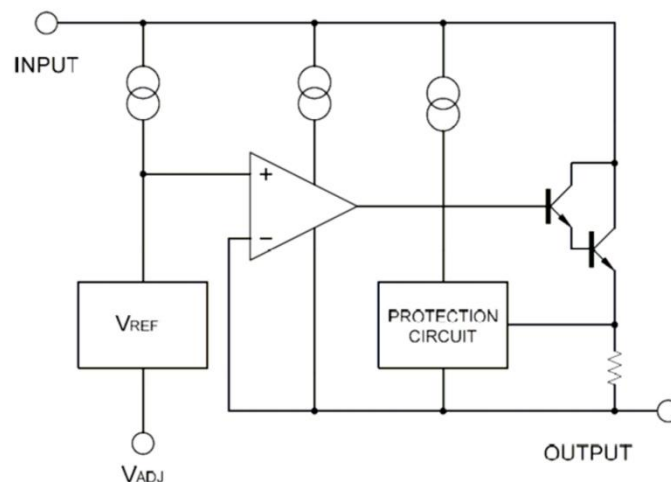

Pin Configuration (Top View)

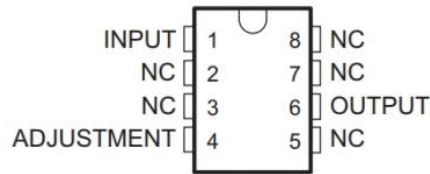

SOP8

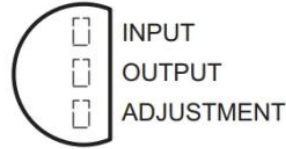

TO92

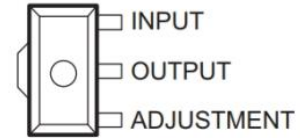

SOT89-3

Absolute Maximum Ratings (Ta=25°C) *

Parameter	Symbol	Min .	Max .	Unit
Input-Output Voltage Differential	V _{in-Vout}		40	V
Power Dissipation	P _D	Internally Limited		
Maximum Operating Junction Temperature	T _J	-40	125	°C
Lead Temperature (Soldering, 10 seconds)	T _{LEAD}		150	°C
Storage Temperature Range	T _{stg}	-65	+150	°C
ESD (human body model)	ESD		4000	V

* : Absolute maximum ratings are stress ratings only and functional device operation is not implied. The device could be damaged beyond Absolute maximum ratings.

Electrical Characteristics (Unless otherwise specified: V_i-V_o=5.0V; I_o=10mA; Ta=25 °C)

Parameter	Test conditions	Symbol	Min .	Typ .	Max .	Unit
Reference Voltage	2.5mA ≤ I _{OUT} ≤ 100mA 5V ≤ V _{IN-VOUT} ≤ 35V P _d ≤ rated dissipation	V _{REF}	1.20	1.25	1.30	V
Line Regulation	5V ≤ V _{IN-VOUT} ≤ 35V	LNR	-	0.01	0.02	% /V
Load Regulation	2.5mA ≤ I _{OUT} ≤ 100mA	LDR	-	0.02	0.5	% /V
Adjust Pin Current		I _{adj}	-	50	100	μA
Adjust Pin Current Change	2.5mA ≤ I _{OUT} ≤ 100mA 3V ≤ V _{IN-VOUT} ≤ 35V, P _d ≤ rated dissipation	Δ I _{adj}	-	0.2	5.0	μA
Minimum Load Current	V _{IN-VOUT} = 35V	I _{L(MIN)}		1.5	2.5	mA
Current Limit	V _{IN-VOUT} = 3V	I _{LIMIT}	100	200		mA
Ripple Rejection	f = 120Hz, V _{IN-VOUT} = 3V, C _{OUT} = 1 μF Tantalum, I _{OUT} = 100mA	PSRR	60	75		dB
Temperature Stability	T _{MIN} ≤ T _J ≤ T _{MAX}			0.7		%
RMS Output Noise (% of V _{OUT})	Ta=25. °C, 10Hz ≤ f ≤ 10kHz	En		0.003		% / V _o
Thermal Resistance, Junction to Ambient	SOP8	θ _{JC}		97.1		°C/W
	TO92			139.5		
	SOT89-3			51.5		

Maximum Power Dissipation is Package Type and Case Temperature dependent.

Application Circuit

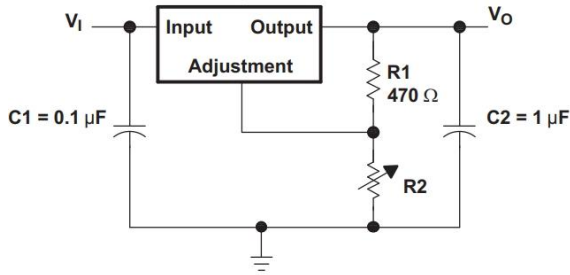

* = C_{IN} is required if the regulator is located near power supply filter.

**= C_O is needed for stability and it improves transient response.

$$V_{OUT} = V_{REF} \times (1 + R2/R1) + I_{ADJ} \times R2$$

Since I_{ADJ} is controlled to less than $100\mu A$, the error associated with this term is negligible in most applications.

Outline Drawing

SOP 8

Unit : mm

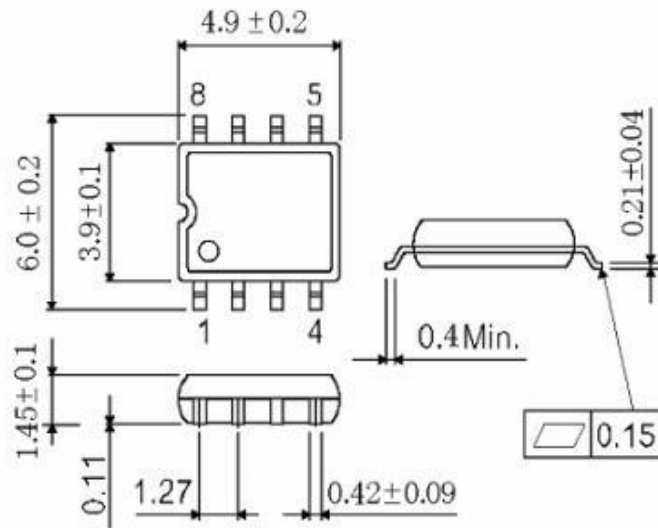

SOT89-3

Unit : mm

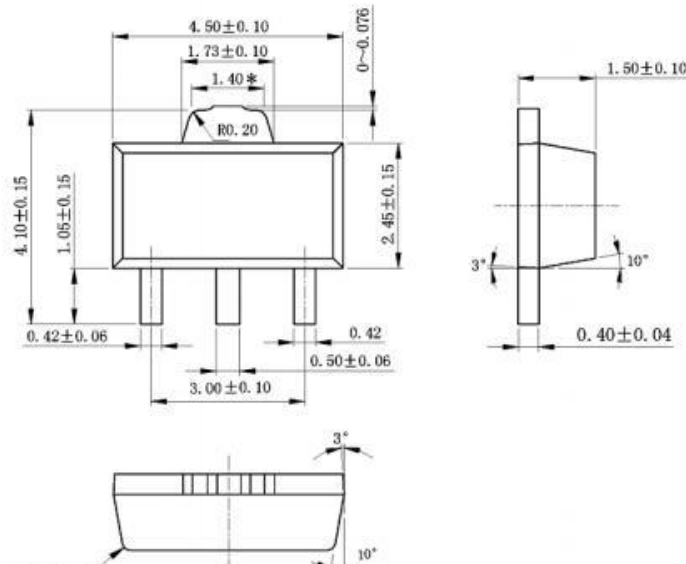

TO92

Unit : mm

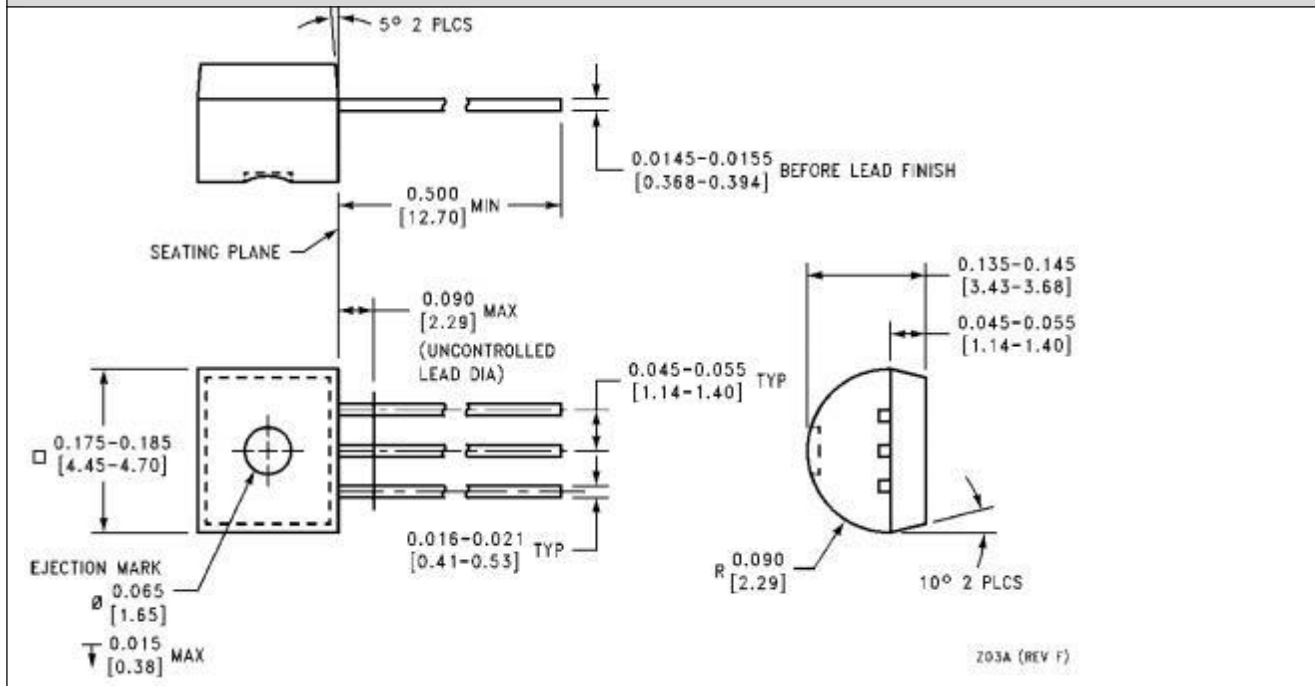

Statement:

- ◇ Shenzhen xinbole electronics co., ltd. reserves the right to change the product specifications, without notice! Before placing an order, the customer needs to confirm whether the information obtained is the latest version, and verify the integrity of the relevant information.
- ◇ Any semiconductor product is liable to fail or malfunction under certain conditions, and the buyer shall be responsible for complying with safety standards in the system design and whole machine manufacturing using Shenzhen xinbole electronics co., ltd products, and take appropriate security measures to avoid the potential risk of failure may result in personal injury or property losses of the situation occurred!
- ◇ Product performance is never ending, Shenzhen xinbole electronics co., ltd will be dedicated to provide customers with better performance, better quality of integrated circuit products.

单击下面可查看定价，库存，交付和生命周期等信息

[>>XBLW\(芯伯乐\)](#)