

## 5050 幻彩贴片式发光二极管

**特点 (characteristic) :**

- \* 外观尺寸 (L/W/H) :5.0\*5.0\*1.6mm  
Appearance dimension (L / w / h): 5.0 x 5.0x 1.6 mm
- \* 发光颜色和胶体: 全彩/半透明雾状胶体  
Luminous color and colloid: Full color / translucent fog colloid
- \* 所有原件集成在5050封装中, 不需要任何其他外围元件构成一个完整的外控像素点  
All components are integrated in the 5050 package, and no other peripheral components are required to form a complete external control pixel.
- \* 断点续传, 单颗IC或灯珠损坏不影响后续整体显示效果  
Breakpoint continuous transmission, single IC or lamp bead damage does not affect the subsequent overall display effect.
- \* 智能反接保护, 12V 电源接反时不会损坏元器件  
Intelligent reverse connection protection, the components will not be damaged when the 12V power supply is reversed.
- \* 内置信号数据整形电路, 接受完本单元数据自动将后续数据整形输出, 保证线路波形畸变不会累加  
Built in signal data shaping circuit, automatically shaping and outputting subsequent data after receiving the data of this unit, ensuring Verify that line waveform distortion will not accumulate.
- \* 灰度调节电路 (256 级灰度可调)  
Grayscale adjustment circuit (256 grayscale adjustable)
- \* 完成 16777216 种颜色的全真色彩显示  
Complete the full color display of 16777216 colors.
- \* 端口扫描频率 2KHz/s  
Port scanning frequency 2khz/s
- \* 串行级联接口, 能通过一根信号线完成数据的接收与解码  
Serial cascade interface, which can receive and decode data through a signal line.
- \* 默认上电不亮灯  
The default power on is not on
- \* 双输入串行级联接口 (DIN. FDIN.)  
Dual input serial cascade interface (din. fdin.)
- \* 任意两点传输距离在不超过 5 米时无需增加任何电路  
There is no need to add any circuit when the transmission distance between any two points is no more than 5m
- \* 当刷新速率 30 帧/秒时, 级联数不小于 1024 点  
When the refresh rate is 30 frames / second, the number of cascades shall not be less than 1024 points
- \* 数据发送速度可达 800Kbps  
Data transmission speed can reach 800kbps
- \* 输出恒流值 9mA, 便于降低内置灯珠功耗  
Output constant current value 9ma, easy to reduce power consumption of built-in lamp beads
- \* 内置高精度和高稳定性振荡器  
Built in high precision and high stability oscillator
- \* 光的颜色高度一致, 性价比高  
The color of light is highly consistent and cost-effective
- \* 采用高压CMOS工艺, 12V单点单控  
High voltage CMOS process, 12V single point single control

## 产品概述 (Product Overview) :

5050-WS2812B 是一个集控制电路与发光电路于一体的智能外控 LED 光源。其外型 与一个 5050LED 灯珠 相同，每个元件即为一个像素点。像素点内部包含了智 能数 字接口数据锁存信号整形放大驱动电路，电源 稳压电路，内置恒流电路， 高精度 RC 振荡器，输出驱动采用专利 PWM 技术，有效保证了像素点内光的 颜色高一致性。芯片采用单线通讯方式， 采用归零码的方式发送信号。芯片在上 电复位以后，接受 DIN 端打来的数据，接受够 24 bit 后， DOUT 端口开始转 发数据，供下一个芯片提供输入数据。在转发之前 ， DOUT 口一直拉低。此时芯 片将不接受新的数据， 芯片 OUTR、OUTG、OUTB 三个 PWM 输出端口根据接受 到的 24 bit 数据，发出相应的不同占空比的信号， 该信号周期在 4 ms。如果 DIN 端输入信号为 RESET 信号，芯片将接收到的数据送显示，芯片将在该信号 结束后重新接受新的数据，在接受完开始的 24 bit 数据后，通过 DOUT 口转发 数据，芯片在没有接受到 RESET 码前，OUTR、OUTG、OUTB 管脚原输出保持不 变，当接受到 80μs 以上低电平 RESET 码后，芯片将刚才接收到的 24 bit PWM 数据脉宽输出到 OUTR、 OUTG、OUTB 引脚上。除 DIN 外， 芯片额外设计了 FDIN 输入端， 接收上一个芯片的 DIN 数据，也就是 上上一个芯片的DOUT 数据。级联时， 如果某一颗芯片损坏，不影响数据传输，后续芯片仍能 正常接收数 据。LED 具有低电压驱动， 环保节能， 亮度高， 散射角度大， 一致性好， 超低功率， 超长寿命等优点。 将控制电路集成于 LED 上面， 电路变得 更加简单， 体积小， 安装更加简便。

5050-WS2812B is an intelligent external control LED light source integrating control circuit and light-emitting circuit. Its appearance is the same as a 5050led light bead, and each component is a pixel. The pixel contains an intelligent digital interface data latch signal shaping and amplifying drive circuit, a power supply voltage stabilizing circuit, a built-in constant current circuit, a high-precision RC oscillator, and a patented PWM technology for output drive, which effectively ensures the high color consistency of light in the pixel. The chip adopts single line communication mode and sends signals by zeroing code. After the chip is powered on and reset, it receives the data from the din end. After receiving enough 24 bits, the dout port starts to forward the data for the next chip to provide input data. The dout port is always pulled down before forwarding. At this time, the chip will not accept new data, and the three PWM output ports of the chip outr, outg and outb will send corresponding signals with different duty cycles according to the received 24 bit data. The signal cycle is 4 ms. If the input signal of DIN end is reset signal, the chip will send the received data to the display, and the chip will accept new data again after the signal ends. After receiving the initial 24 bit data, the chip will forward the data through dout port. Before the chip receives the reset code, the original output of outr, outg and outb pins will remain unchanged. After receiving the low-level reset code above 80 μ s, The chip outputs the 24 bit PWM data pulse width just received to outr, outg and outb pins. In addition to DIN, the chip has an additional fdin input to receive the din data of the previous chip, that is, the dout data of the previous chip. During cascading, if one chip is damaged, data transmission will not be affected, and subsequent chips can still receive data normally. LED has the advantages of low voltage drive, environmental protection and energy saving, high brightness, large scattering angle, good consistency, ultra-low power and long service life. By integrating the control circuit into the LED, the circuit becomes simpler, smaller and easier to install.

## 应用领域 (product application) :

- \* LED全彩发光字灯串，LED全彩模组，LED外观，情景照明  
Led full-color luminous word lamp string, led full-color module, LEDappearance, scene lighting
- \* LED幻彩软硬灯条，LED护栏管，LED异形屏  
Led magic color soft and hard light strip, LED guardrail tube, LED heterosexual screen
- \* 各种电子产品，电器设备跑马灯  
All kinds of electronic products, electrical equipment, runninglights



## 目录

---

### Catalogue

<b>电性参数</b>	
Electrical Characteristics.....	4
<b>典型特性曲线</b>	
Typical Characteristic Curves.....	7
<b>外形尺寸</b>	
Outline Dimensions.....	8
<b>包装</b>	
Packaging.....	10
<b>焊接指导</b>	
Guideline for Soldering.....	12
<b>使用注意事项</b>	
Precautions.....	14

## 电性参数

### Electrical Characteristics

◇极限参数 Limit parameter (温度=25℃):

项目 Item	符号 Symbol	最大额定值 Absolute Maximum Rating	单位 Unit
逻辑电源电压Logic supply voltage	Vin	+5.0~+24.0	V
输出端口耐压 Output port withstand voltage	Vout	26	V
逻辑输入电压Logic input voltage	Vil	-0.5~5.5	V
输出电流Output current	Iol1	12	mA
工作温度Operating Temperature	Topr	-40~+85	℃
贮藏温度Storage Temperature	Tstg	-50~+150	℃
ESD耐压ESD withstand voltage	VESD	4K	V

电气参数 Electrical parameters (如无特殊说明, Ta=-20~+70℃) (Unless otherwise specified, Ta=-20~+70℃)

参数名称 Parameter	符号Symbol	最小Min	典型Typ	最大Max	单位 Unit
芯片电源电压Chip power supply voltage	Vin	10.8	12	13.2	V
R/G/B输出驱动电流 R/G/B output drive current	Iout	8.82	9	9.18	mA
低电平输入电压Low level input voltage	V <sub>IH</sub>	-	-	1	V
高电平输入电压High level input voltage	V <sub>IL</sub>	4	-	-	V
PWM频率PWM frequency	f <sub>PWM</sub>	-	1.2	-	KHZ
静态功耗Static power consumption	I <sub>dd</sub>	-	2	-	mA

开关特性 Switching characteristics: 如无特殊说明, Ta=-20~+70℃) (Unless otherwise specified, Ta=-20~+70℃)

参数名称 Parameter	符号 Symbol	最小 Min	典型 Typ	最大 Max	单位 Unit	测试条件 Test conditions
数据传输速率 Data transfer rate	F <sub>DIN</sub>	-	800	-	KHZ	-
传输延迟时间 Transmission delay time	t <sub>PLZ</sub>	-	-	500	ns	-

**数据传输时间 ( TH+TL=1.25μs±300ns)**

Data transmission time ( TH+TL=1.25μs±300ns)

名称 Name	描述 Describe	典型 Typ	容许误差 Allowable error
T0H	0码, 高电平时间 0 code, high level time	0.3μs	±0.05us
T1H	1码, 高电平时间 1 code, high level time	0.9μs	±0.05us
T0L	0码, 低电平时间 0 code, low level time	0.9μs	±0.05us
T1L	1码, 低电平时间 1 code, low level time	0.3μs	±0.05us
Trst	Reset码, 低电平时间 Reset code, low level time	≥80us	±0.05us

**动态参数 Dynamic parameter**

参数 Parameter	符号 Symbol	测试条件 Test conditions	典型 Typ	单位 Unit
数据传输数据 Data transmission data	DIN	5.2	800	KHZ
Din/FDin到Do延迟 Din/fdin to do delay	Tdly	5.2	500	ns
R/G/B输出电流 R/G/B output current	Iron/Igon/Ibon	Vr/Vg/Vb=3V	13.2	mA

**时序波形图 Time sequence waveform**

输入码型 Input code type:

连接方法 Connection method:

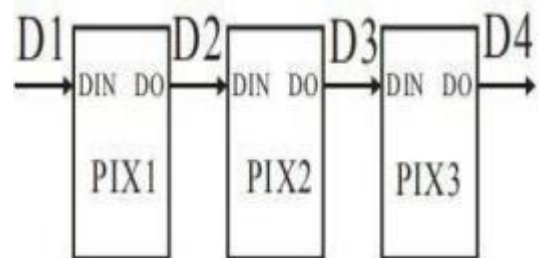
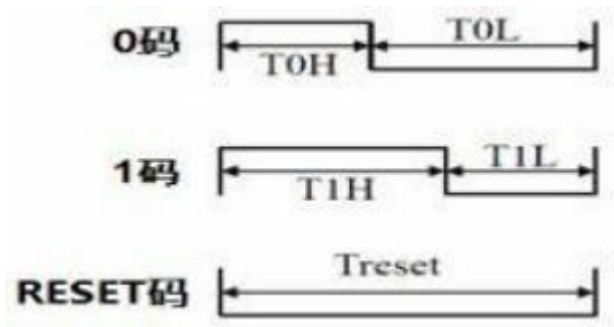

应用电路图 Application circuit diagram

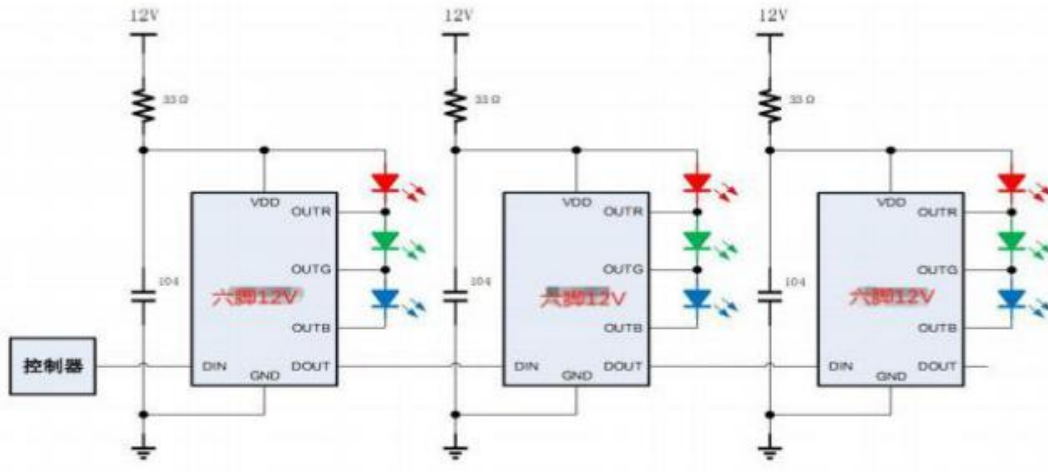

数据传输方法 Data transmission method

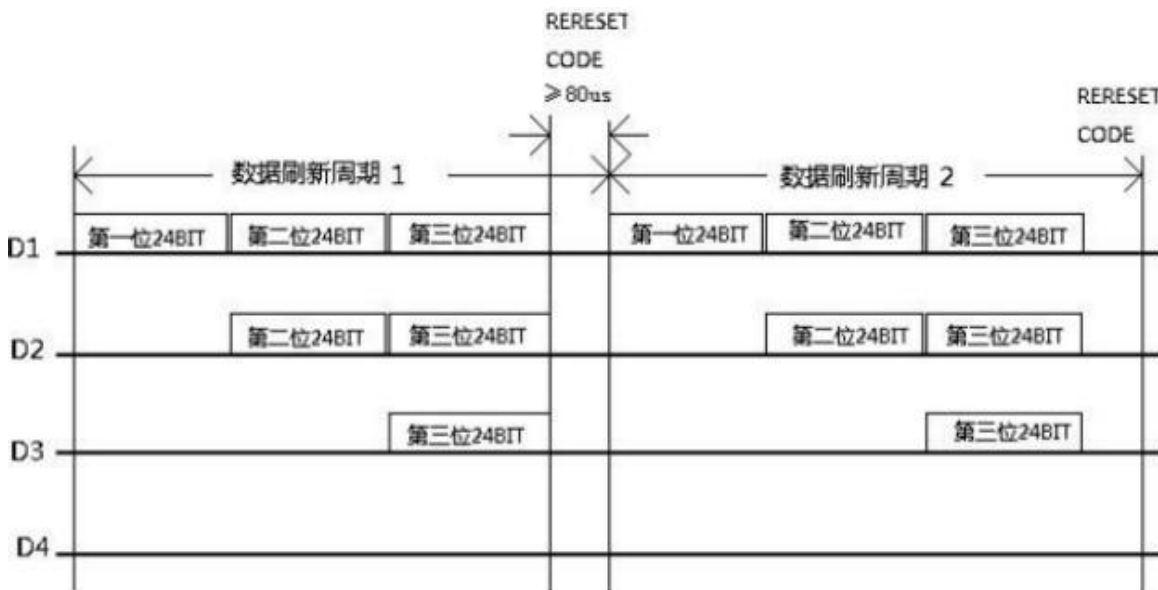

注：其中 D1 为 MCU 端发送的数据，D2、D3、D4 为级联电路自动整形转发的数据  
 Note: D1 refers to the data sent by MCU, and D2, D3 and D4 refer to the data automatically shaped and forwarded by cascade circuit.

数据格式 Data format

G7	G6	G5	G4	G3	G2	G1	G0	R7	R6	R5	R4	R3	R2	R1	R0	B7	B6	B5	B4	B3	B2	B1	B0
----	----	----	----	----	----	----	----	----	----	----	----	----	----	----	----	----	----	----	----	----	----	----	----

注：高位先发，按照 GRB 的顺序发送数据 Note: high order first mover sends data in the order of GRB

曲型特效曲线

Typical special effect curve

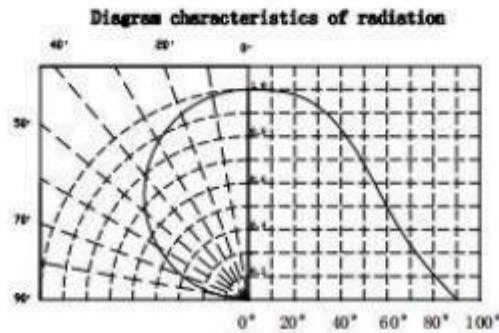
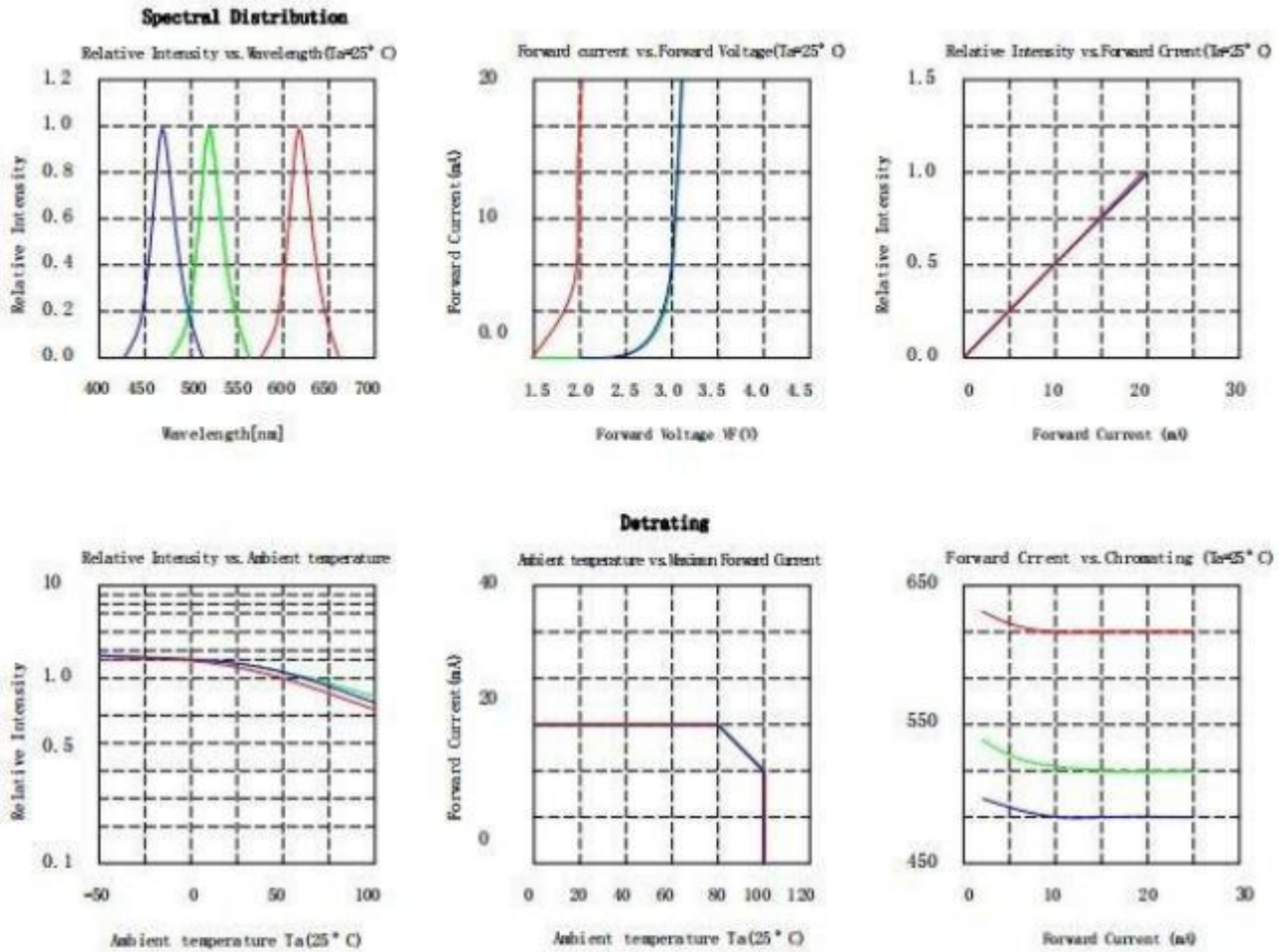

## 外形尺寸(1)

### Outline Dimension(1)

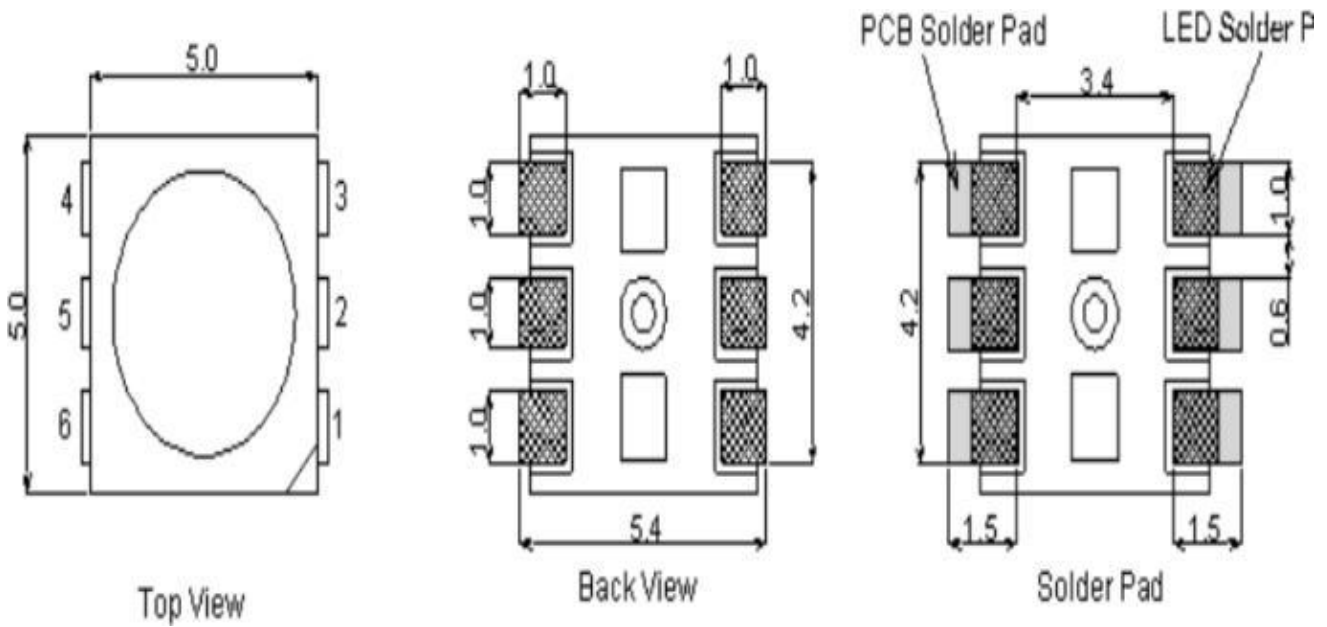

- 注: 1. 单位 : 毫米 (mm) Unit: mm  
 2. 公差 : 如无特别标注则为± 0.1 mm Tolerances: ± 0.1 mm if unmarked.

### LED引脚示意图 LED Pin diagram

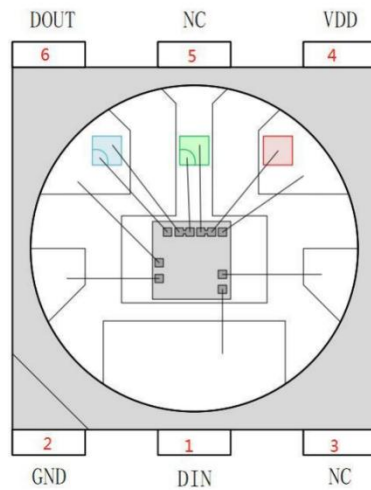



## 外形尺寸 (2)

## Outline Dimension(2)

## LED引脚功能 LED Pin function

引脚序号 Pin serial number	符号 Symbol	管脚名 Pin name	功能描述Function description
1	DIN	数据输入 Data input	控制数据信号输入脚/辅助信号输出 Control data signal input pin / auxiliary signal output
2	GND	地线 Ground wire	接地Grounding
3	NC	空脚 Empty foot	PCB LAYOUT 时悬空处理, 连接到其他线路会引起电路工作异常 When PCB layout is suspended, connecting to other circuits will cause abnormal circuit operation
4	VDD	电源 Source	LED芯片电源 LED chip power supply
5	NC	空脚 Empty foot	PCB LAYOUT 时悬空处理, 连接到其他线路会引起电路工作异常 When PCB layout is suspended, connecting to other circuits will cause abnormal circuit operation
6	DO	数据输出 Data output	控制数据信号输入脚 Control data signal input pin

## 包装 (1)

### Packaging (1)

编带包装 Fabric with packaging

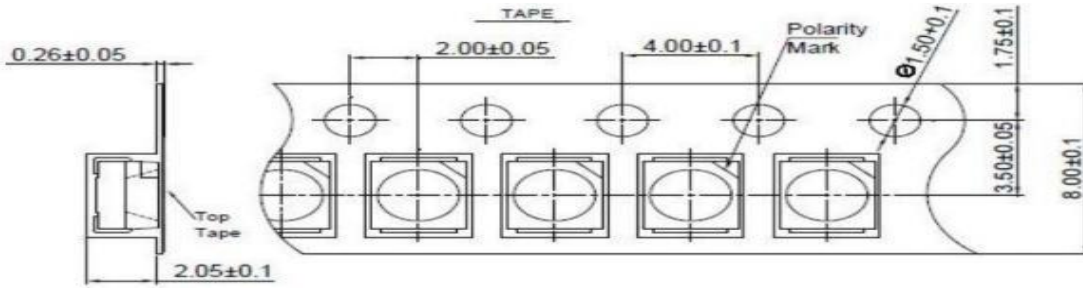

注:

1. 尺寸单位为毫米(mm).
1. Size unit is mm (mm).
2. 尺寸公差是±0.1mm.
2. The dimensional tolerance is ± 0.1mm.

卷轴尺寸 Scroll size

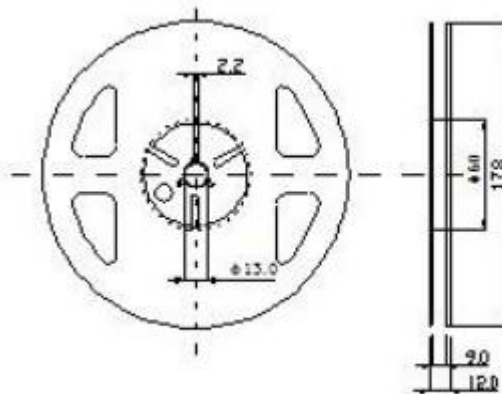

## 包装 (2)

### Packaging (2)

#### ◇ 防潮防静电包装 Moisture Proof and Anti-Electrostatic Foil Bag

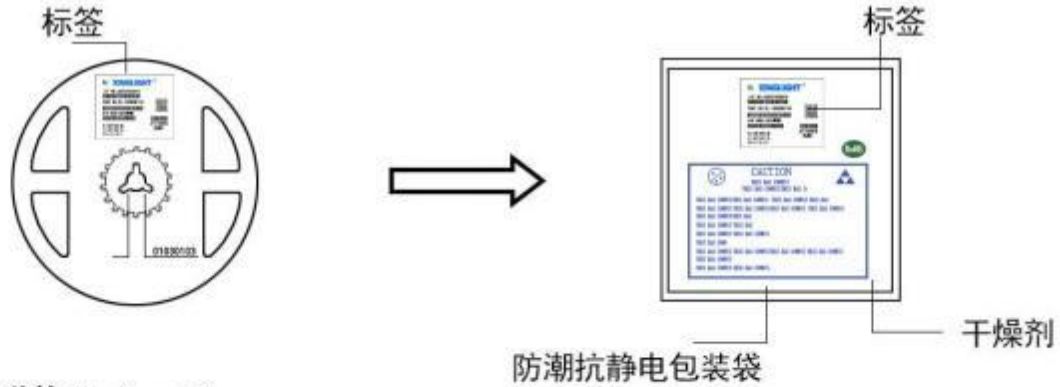

#### ◇ 外包装箱 Cardboard Box



Capacity 5 or 10 reels per box (内箱容量: 50或100卷)

#### ◇ 标签说明: Label Explanation

- LOT NO: 批次信息
- PART NO: 产品型号
- BIN CODE: 产品名称
- WL: 波长范围
- IV: 光强范围
- VF: 电压范围



## 焊接指导（1）

### Guideline for Soldering (1)

回流焊注意事项 Attention to Reflow Welding:

1、无铅锡膏的温度曲线建议，手工焊接时，烙铁温度控制在 300℃以下，且时间不可超过 3 秒

The temperature curve of lead-free solder paste is recommended. During manual welding, the temperature of the soldering iron shall be controlled below 300 °C and the time shall not exceed 3 seconds

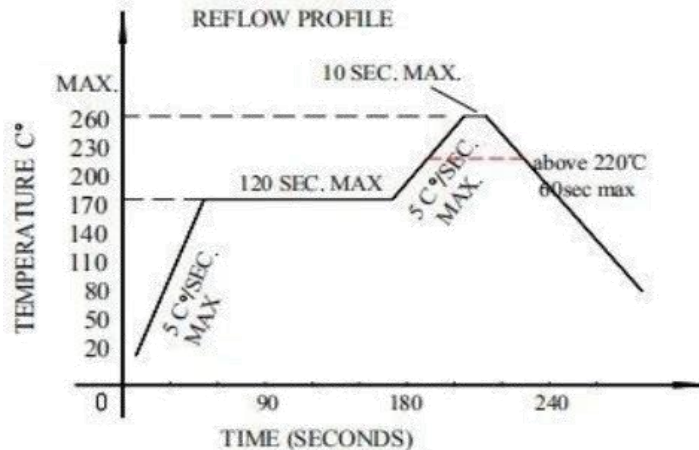

2、建议检查终端产品是否需要经历二次回流焊工艺，二次回流焊工艺具有一定品质风险性，如需请自行评估并尽量缩短二次回流焊间隔时间（建议不超过4小时）；

It is recommended to check whether the terminal product needs to undergo secondary reflow welding process. The secondary reflow welding process has certain quality risks. If you need to evaluate yourself and shorten the secondary reflow welding interval as much as possible(recommended not to exceed 4 hours);

3、焊接期间，加热时不要在 LEDs 上添加任何压力；

Do not add any pressure to the LEDs when heated during welding;

4、焊接后，正常回温至 40℃以下后才可过电流。

After welding, the normal return temperature is below 40 °C before the current can be passed.

---

## 焊接指导 (2)

### Guideline for Soldering (2)

#### 清洗 Cleaning

在焊接后推荐使用酒精进行清洗，在温度不高于 30°C 的条件下持续 3 分钟，不高于 50°C 的条件下持续 30 秒。使用其他类似溶剂清洗前，请先确认使用的溶剂不会对 LED 的封装和环氧树脂部分造成损伤。

超声波清洗也是有效的方法，一般最大功率不应超过 300W，否则可能对 LED 造成损伤。请根据具体的情况预先测试清洗条件是否会对 LED 造成损伤。

It is recommended that alcohol be used as a solvent for cleaning after soldering. Cleaning is to go under 30°C for 3 minutes or 50°C for 30 seconds. When using other solvents, it should be confirmed beforehand whether the solvents will dissolve the package and the resin or not.

Ultrasonic cleaning is also an effective way for cleaning. But the influence of Ultrasonic cleaning on LED depends on factors such as ultrasonic power. Generally, the ultrasonic power should not be higher than 300W. Before cleaning, a pretest should be done to confirm whether any damage to LEDs will occur.

- \* **注意：** 此一般指导原则并不适用于所有 PCB 设计和焊接设备的配置。具体工艺受到诸多因素的影响，请根据特定的PCB设计和焊接设备来确定焊接方案。
- \* **Note:** This general guideline may not apply to all PCB designs and configurations of all soldering equipment. The technics in practise is influenced by many factors, it should be specialized base on the PCB designs and configurations of the soldering equipment..

---

## 使用注意事项 (1)

---

### Precautions (1)

#### 存储要求: Storage requirements

1. 推荐储存环境: 温度:  $5^{\circ}\text{C} - 30^{\circ}\text{C}$ ; 湿度: 相对湿度 60% 以下;

Recommended storage environment: temperature:  $5^{\circ}\text{C} - 30^{\circ}\text{C}$ ; Humidity: Relative humidity below 60;

2. 防潮袋密封包装储存时间为15天, 起始时间以包装标签日期为准, 包装袋封口良好并无漏气现象, 如超过15天的LED需放进 $65 \pm 5^{\circ}\text{C}$ ; 相对湿度 $\leq 10\% \text{RH}$ 的烤箱烘烤, 烘烤时间: 24小时;

The storage time of the waterproof bag sealed packaging is 15 days. The starting time is based on the date of the packaging label. The packaging bag has a good sealing and no leakage. For example, LEDs over 15 days need to be put into  $65 \pm 5^{\circ}\text{C}$ ; Relative humidity  $\leq 10\% \text{RH}$  oven baking time: 24 hours;

3、表面贴装器件(SMDs)属于潮湿敏感性元件, 空气中的湿气通过扩散渗透到产品中。当 SMD 元件焊接到电路板上的过程是将其通过温度为  $150^{\circ}\text{C} - 260^{\circ}\text{C}$  的回流焊, 在高温状态下, 渗入其中的湿气快速膨胀产生足够的蒸汽压力损伤或毁坏 LED 元件, 从而出现材料内胶裂、分层或金线损失等可靠性失效问题;

Surface mount devices(SMDs) are moist sensitive elements, and moisture in the air penetrates the product through diffusion. When the SMD component is welded to the circuit board, it is welded through a return welding at a temperature of  $150^{\circ}\text{C} - 260^{\circ}\text{C}$ . At a high temperature, the moisture that infiltrates it rapidly expands to produce enough steam pressure damage or damage to the LED component. Therefore, there are reliability failure problems such as internal cracking, delamination or gold wire loss;

4、除潮烘烤条件: 低温除湿, 即去除铝箔袋后将料盘放置在柜式干燥箱内进行 $65 \pm 5^{\circ}\text{C}$  / 相对湿度 $\leq 10\% \text{RH}$ , 烘烤时间 $\geq 24$ 小时的除湿作业 (如属热风烤箱则建议除湿时关闭烤箱进风口开关, 关键确保箱内相对湿度 $\leq 10\% \text{RH}$ )! 且回温过程必须在干燥的环境下进行! 建议产品除湿后在4个小时内完成贴片固焊作业;

Dehumidification baking conditions: low temperature dehumidification, that is, after removing aluminum foil bags, the tray is placed in a cabinet drying box for  $65 \pm 5^{\circ}\text{C}$  / relative humidity of  $10\% \text{RH}$ , The baking time is a 12-hour dehumidification(in the case of a hot air oven, it is recommended to close the oven inlet switch when dehumidifying, and the key is to ensure that the relative humidity in the box is  $10\% \text{RH}$ )! And the warming process must be carried out in a dry environment! Recommends that the product be dehumidified and finished within 4 hours;

5、产品拆封后, LED 在温度 $\leq 30^{\circ}\text{C}$ , 相对湿度 $\leq 60\% \text{RH}$  的条件下, 请在 12H 内使用完, 若没有使用完的产品需以  $65 \pm 5^{\circ}\text{C} / 24\text{H}$  除潮后密封, 建议放入干燥柜中存放;

After the product is unsealed, the LED is used within 12H under conditions of temperature  $\leq 30^{\circ}\text{C}$  and relative humidity  $\leq 60\% \text{RH}$ . If the product is not used, it must be sealed after dehumidification with  $65 \pm 5^{\circ}\text{C} / 24\text{H}$ .  
Suggestions for storage in drying cabinets;

## 使用注意事项 (2)

### Precautions (2)

#### 防护措施: Protection measures:

- 1、LED器件封装胶水采用的是硅树脂系原材，终端产品如需户外使用需对器件做二次防护措施并请特别注意；  
/The packaging glue for LED devices is made of silicone. If the end product needs to be used outdoors, the device must be protected twice. Please pay special attention to it:
  - A、建议检查各个工艺流程环节应规避产品有堆叠及不规则棱角物伤及产品胶体； /It is recommended that the inspection of various process links should avoid products with stacking and irregular angular injuries and product colloids;
  - B、建议检查各个工艺流程环节应规避产品与硫、卤、酸、醇、碱、酮类强氧化物、塑化剂等腐蚀性物质接触； /It is recommended to avoid contact with corrosive substances such as sulfur, halogen, acid, alcohol, alkali, ketone strong oxide and plasticizer;
  - C、建议检查终端产品是否需要封盖、灌胶、裸板高温挤出、超声等二次封装工艺，如需请评估可能伤及LED器件的风险；是否需要刷胶、涂油、抹漆等二次涂装工艺，如需请评估可能导致器件胶体表面凹凸、污垢等因素影响发光、导热的风险。 /recommends checking whether the terminal product needs to cover, glue, bare plate high temperature extrusion, ultrasound and other secondary packaging process, if necessary, please assess the risk of possible damage to LED devices; If need brush glue, oil, paint and other secondary painting process, if you need to assess the device glue surface bump, dirt and other factors may affect the light emission, heat conductivity risk.

#### 设计建议: Design suggestions:

- 1、电路设计时，建议使用定电流驱动设计，如以定电压设计，请考虑不同电压所造成的影响； /When designing a circuit, it is recommended to use a constant current drive design. If you design with a constant voltage, consider the impact of different voltages;
- 2、LED产品为单向导通性，使用安装前请确认产品极性，一般产品缺口边为产品负极，若反向安装，不能正常点亮，且在施加电压时容易造成LED芯片损伤或失效； /LED products are simple guides, please confirm the polarity of the product before using the installation. The general product gap edge is the negative electrode of the product. If it is installed in the opposite direction, it can not be lit normally, and it is easy to cause LED chip damage or failure when voltage is applied;
- 3、注意正确的电路设计，不当之设计与电流控制，易造成LED失效，如电流过大引起寿命问题甚至烧毁，电流过小引起亮度不足等； /Pay attention to the correct circuit design, improper design and current control, it is easy to cause LED failure, such as excessive current causing life problems or even burning, too small current causing insufficient brightness, etc.;
- 4、不同BIN号之LED建议分开使用，若需安装在同一个组件时，请先确认是否可满足相关电气及光学特性要求，如电流是否均衡，光色、亮度的一致性； /The LEDs of different BIN numbers are recommended to be used separately. If you need to install on the same component, please first confirm whether the relevant electrical and optical characteristics can be met, such as whether the current is balanced, the consistency of light color, brightness, etc
- 5、本规格书列出的产品是设计于普通电子产品的应用，例如电器‘可视化设备、通信产品等等。因此，建议这些产品不应该用于医疗设施、手术设备、航天器、核电控制系统、灾难/犯罪预防设备等类似的设备。这些产品的错误使用可能直接或间接导致威胁到人们的生命或者导致伤害及财产损失。 /The products listed in this specification are designed for applications of ordinary electronic products, such as electrical 'visual equipment, communication products, etc.. Therefore, it is recommended that these products should not be used for similar equipment such as medical facilities, surgical equipment, spacecraft, nuclear power control systems, and disaster-crime prevention equipment. Misuse of these products may directly or indirectly result in a threat to human life or lead to injury and loss of property.

## 使用注意事项 (3)

### Precautions (3)

#### 其他事项: Others

直接用手拿取产品不但会污染封装树脂表面, 也可能由于静电等因素导致产品性能的改变。过度的压力也可能直接影响封装内部的管芯和金线, 因此请勿对产品施加过度压力, 特别当产品处于高温状态下, 例如在回流焊接过程中。

When handling the product, touching the encapsulant with bare hands will not only contaminate its surface, but also affect on its optical characteristics. Excessive force to the encapsulant might result in catastrophic failure of the LEDs due to die breakage or wire deformation. For this reason, please do not put excessive stress on LEDs, especially when the LEDs are heated such as during Reflow Soldering.

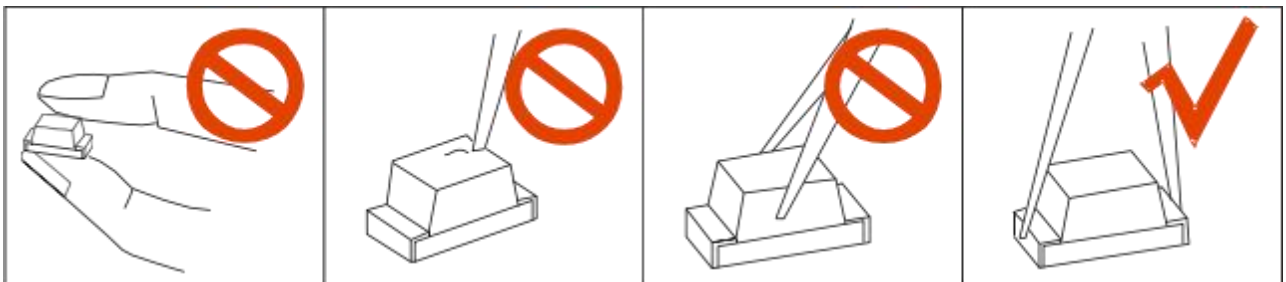

LED 的环氧树脂封装部分相当脆弱, 请勿用坚硬、尖锐的物体刮、擦封装树脂部分。在用镊子夹取的时候也应当小心注意。

The epoxy resin of encapsulant is fragile, so please avoid scratch or friction over the epoxy resin surface. While handling the product with tweezers, do not hold by the epoxy resin, be careful.

#### 眼睛保护忠告: Safety Advice For Human Eyes

LED 发光时, 请勿直视发光光源, 特别是对于一些光强较高的 LED, 强光可能伤害你的眼睛。

Viewing direct to the light emitting center of the LEDs, especially those of great Luminous Intensity, will cause great hazard to human eyes. Please be careful.



单击下面可查看定价，库存，交付和生命周期等信息

[>>XINGLIGHT\(成兴光\)](#)