

PCB Layout(pattern siade)

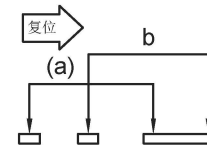

Circuit Diagram

**NOTE:**  
 Rating: DC 12V 50mA  
 Operating Force:200±100gf  
 Lifetime:10,000 Cycles

PAPT NO	L
SK-3270B-L1	2.0
SK-3270B-L2	3.0
SK-3270B-L3	4.0

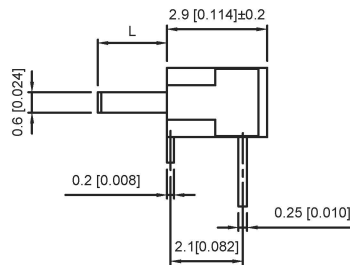
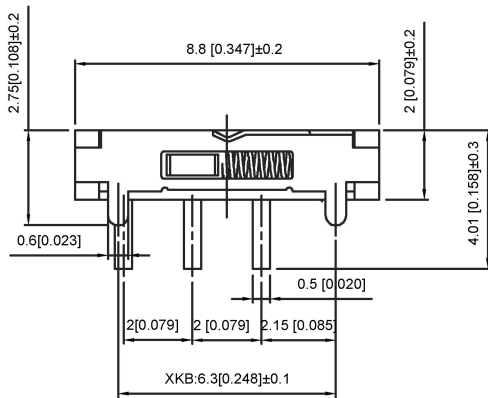

ITEM	PAPT NAME	TER.NO	QTY	MATERIAL	FINISHING	REMARK
⑤	Terminal	3	3	Brass (0.30t)	ag Plated	
④	Contact spring	1	1	Phosphor branze	ag Plated	
③	Base	1	1	Lcp	Black	
②	Cover	1	1	Sus	Natural	
①	Keystake	1	1	Pa46	Black	

广东星坤科技股份有限公司

生	日期
ΔX	
ΔX	
ΔX	
MARK	文件工程章
DESCRIPTION	REVISIONS
DATE	REVISED
APPROVED	UNSPECIFIED TOLERANCES
units: mm	
tolerance:	
X.X	±0.2mm
X.XX	±0.1mm
X.XXX	±0.05mm

DSND	DATE	SCALE: N/A	MODEL TYPE: SLIDE SWITCH
DWN	DATE	VIEW:	PART NO.:
CHKD	DATE	UNIT: mm/in	DWG NO.: SK-3270B-X
APPD	DATE	SIZE: A4	WEIGHT: 1.0g
XKB INDUSTRIAL PRECISION CO., LIMITED			SHEET: 1/1
			REVISION: A0

单击下面可查看定价，库存，交付和生命周期等信息

[>>XKB Connectivity\(中国星坤\)](#)