

**P.C.B LAND DIMENSION**

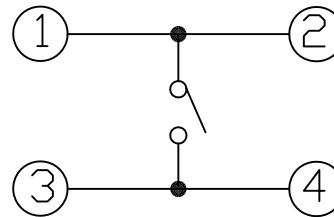
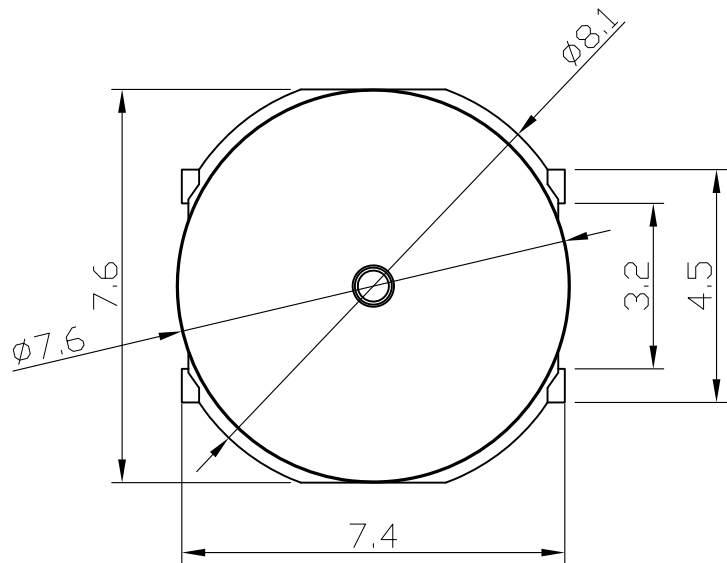
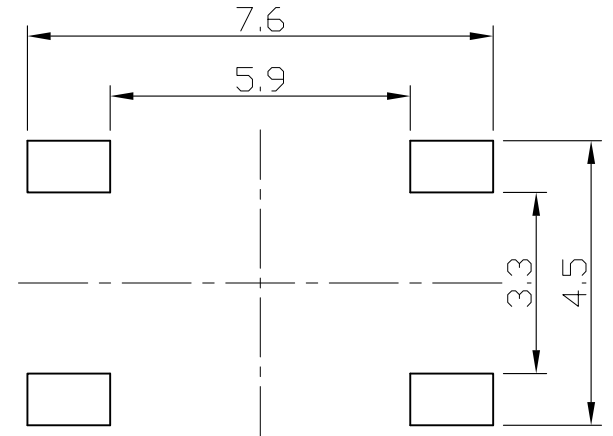

**CIRCUIT DIAGRAM**

**SPECIFICATION**

Contact Rating: 50mA, 12V DC  
 Contact Resistance: 100mΩ max  
 Insulation Resistance: 100mΩ min. 500V DC  
 Dielectric Strength: 250V AC/1minute

**REFERENCE DRAWING**

0.73 mm	WHITE	BALK	250±50gf	100,000 Cycles
"H"	STEM COLOR	BASE COLOR	O/FORCE	LIFE

DSND		DATE		SCALE: N/A	MODEL TYPE: <b>TACT SWITCH</b>
DWN		DATE		VIEW:	PART NO.:
CHKD		DATE		UNIT: mm	DWG NO.: <b>TS-7476-C</b>
APPD		DATE		SIZE: A4	
UNSPECIFIED TOLERANCES					WEIGHT
<b>XKB INDUSTRIAL PRECISION CO., LIMITED</b>					SHEET
					REVISION
					1.0g
					1/1
					A0

					units: mm
					tolerance:
Δx					X.X ±0.2mm
Δx					X.XX ±0.1mm
Δx					X.XXX ±0.05mm
MARK	DESCRIPTION	DATE	REVISED	APPROVED	
REVISIONS					
www.xk-dg.cn www.helloxkb.co					

单击下面可查看定价，库存，交付和生命周期等信息

[>>XKB Connectivity\(中国星坤\)](#)