

### XKB CONNECTICITY

#### NOTES:

##### 1.MATERIAL:

HOUSING: THERMOPLASTIC HIGH-TEMP UL94V-0 BLACK COLOR.  
CONTACT: COPPER ALLOY.  
SHELL: STAINLESS STEEL.

##### 2.FINISH:

2.1. TERMINAL CONTACT:(SEE TAB)GOLD PLATING ALL OVER 50u"  
Min NICKEL AND GOLD PLATING G/F ALL OVER 50u" Min NICKEL ON  
SOLDER AREA

2.2. OUT SHELL:50u" Min. NICKEL ALL OVER

##### 3.APPLIED TO IR SOLDERING PROCESS.

##### 4. SPECIFICATION:

##### 4.1.ELECTRICAL CHARACTERISTICS

CONTACT CURRENT RATING:Signal pin 1A,Power pin 1.8A

VOLTAGE RATING:30V AC rms.

CONTACT RESISTANCE:30mΩ MAX.

DIELECTRIC WITHSTANDING VOLTANGE:

UNMATEP CONTACT 100V AC rms. 60MHZ FOR 1 MINUTE.

INSULATION RESISTANCE:1000MΩ MIN. 100V DC

TEMPERATURE RANGE:-30°C TO +85°C

##### 4.2.MECHANICAL:

INSERTION FORCE:35N MAX.

▲ WITHDRAWAL FORCE:5N MIN,25N MAX.

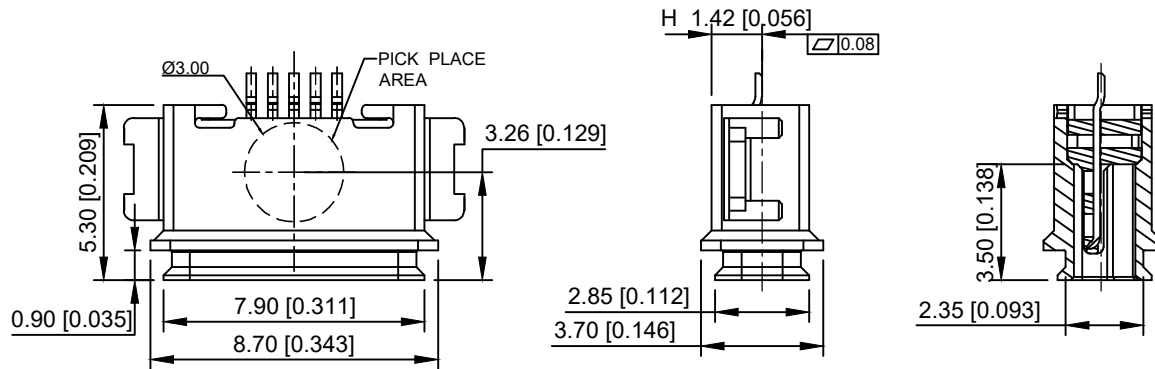

### XKB CONNECTICITY

U-E-M8SS-C-1

1:G/F 2:5u" 3:10u"  
4:15u" 5:30u"

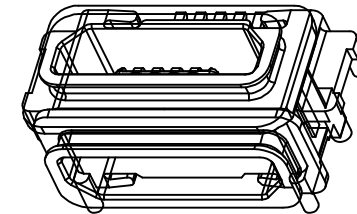

# IP-X8

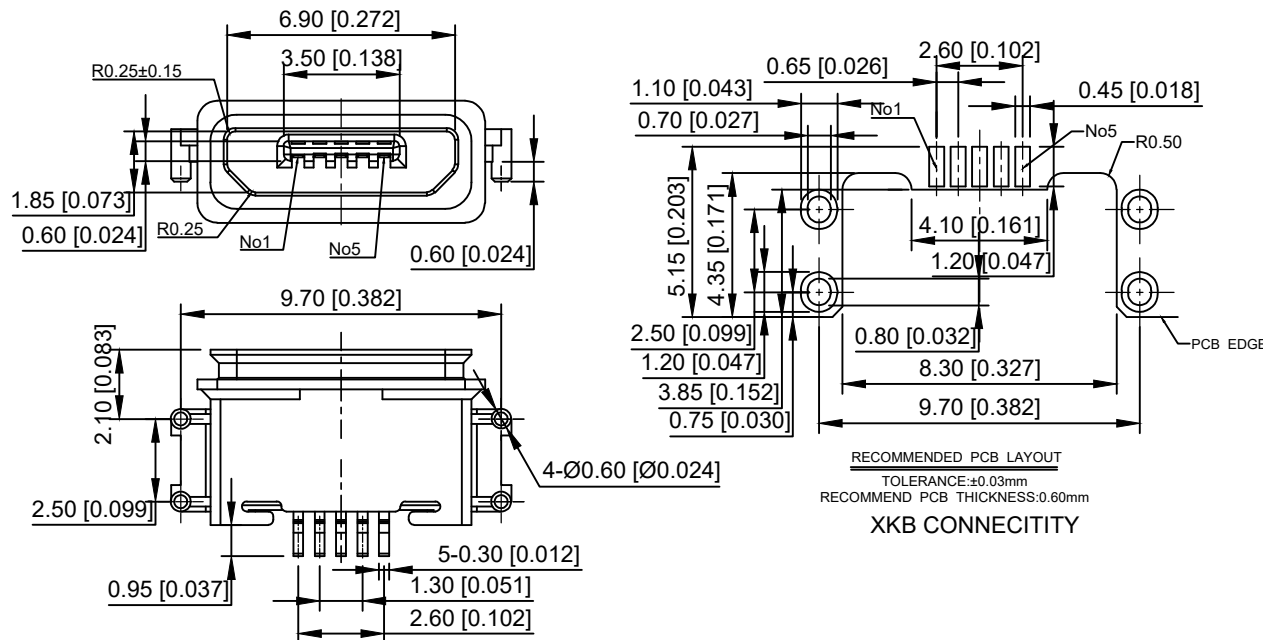

RECOMMENDED PCB LAYOUT  
TOLERANCE:±0.03mm  
RECOMMEND PCB THICKNESS:0.60mm  
XKB CONNECTICITY

					DSND	DATE	SCALE: N/A	MODEL TYPE: MICRO USB		
					DWN	DATE	VIEW:	PART NO.: U-E-M8SS-C-1		
					CHKD	DATE	UNIT: mm/in	DWG NO.: U-E-M8SS-C-1		
					APPD	DATE	SIZE: A4			
REVISIONS					XKB INDUSTRIAL PRECISION CO.,LIMITED			WEIGHT	SHEET	REVISION
UNSPECIFIED TOLERANCES								1.0g	1/1	A0
www.xk-dg.cn www.helloxkb.com www.helloxkb.cn										

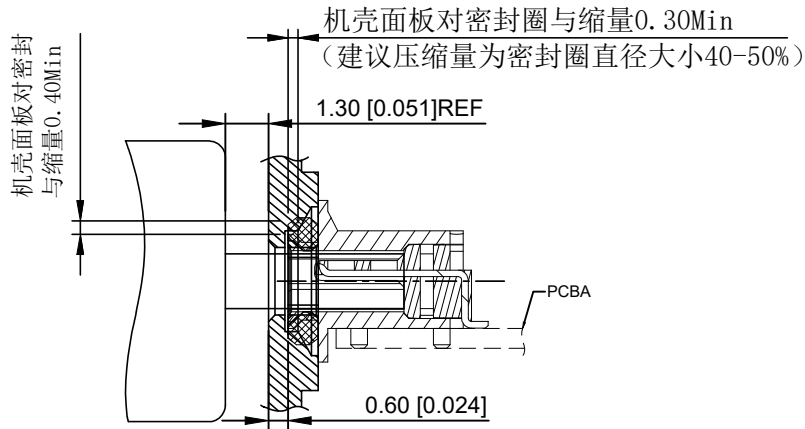

COMPRESSION RATIO TO BE 40%-50%

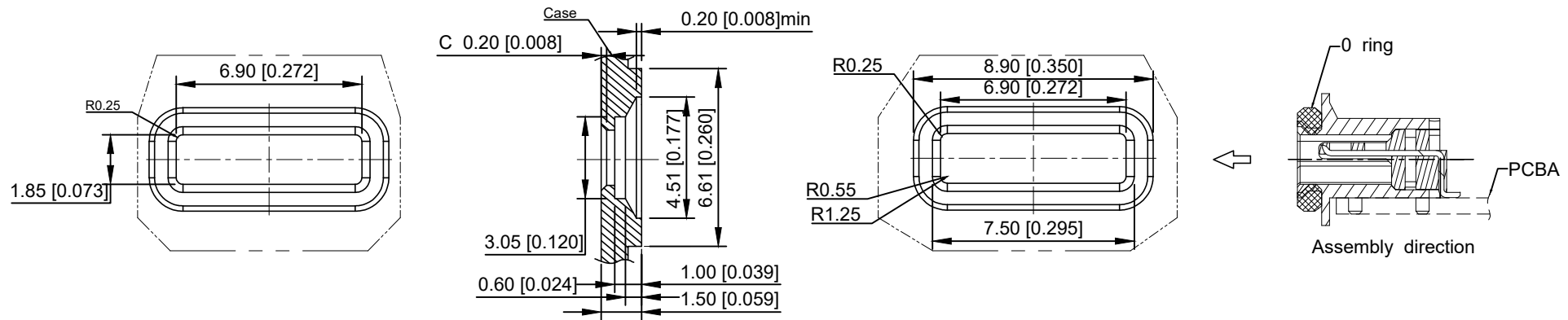
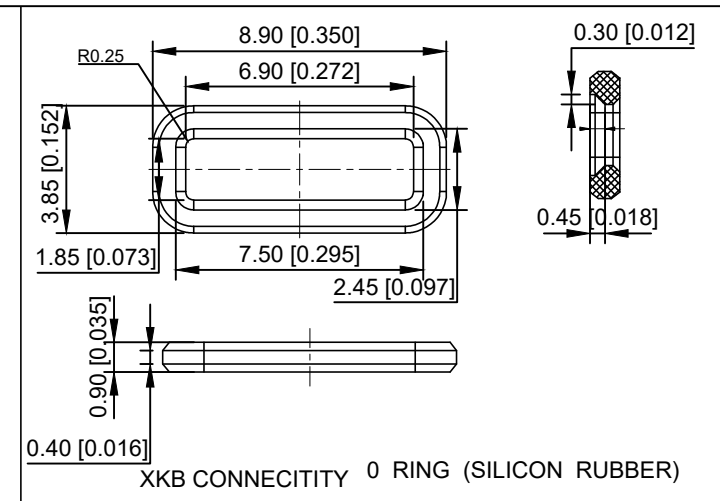

RECOMMENDED OPEN DIMENSION OF CASE  
TOLERANCE: ±0.03mm  
MATTING AREA WITH SEALING RING  
XKB CONNECTICITY

					ANGLAR	±5°	DSND	DATE	SCALE: N/A	MODEL TYPE: MICRO USB		
					L ≤ 4	±0.2	DWN	DATE	VIEW:	PART NO.: U-E-M8SS-C-1		
					4 < L ≤ 16	±0.3	CHKD	DATE	UNIT: mm/in	DWG NO.: U-E-M8SS-C-1		
					16 < L ≤ 63	±0.4	APPD	DATE	SIZE: A4			
					L > 63	±0.5						
					UNSPECIFIED TOLERANCES		XKB INDUSTRIAL PRECISION CO., LIMITED			WEIGHT	SHEET	REVISION
										1.0g	1/1	A0

单击下面可查看定价，库存，交付和生命周期等信息

[>>XKB Connectivity\(中国星坤\)](#)