

XKB Connectivity

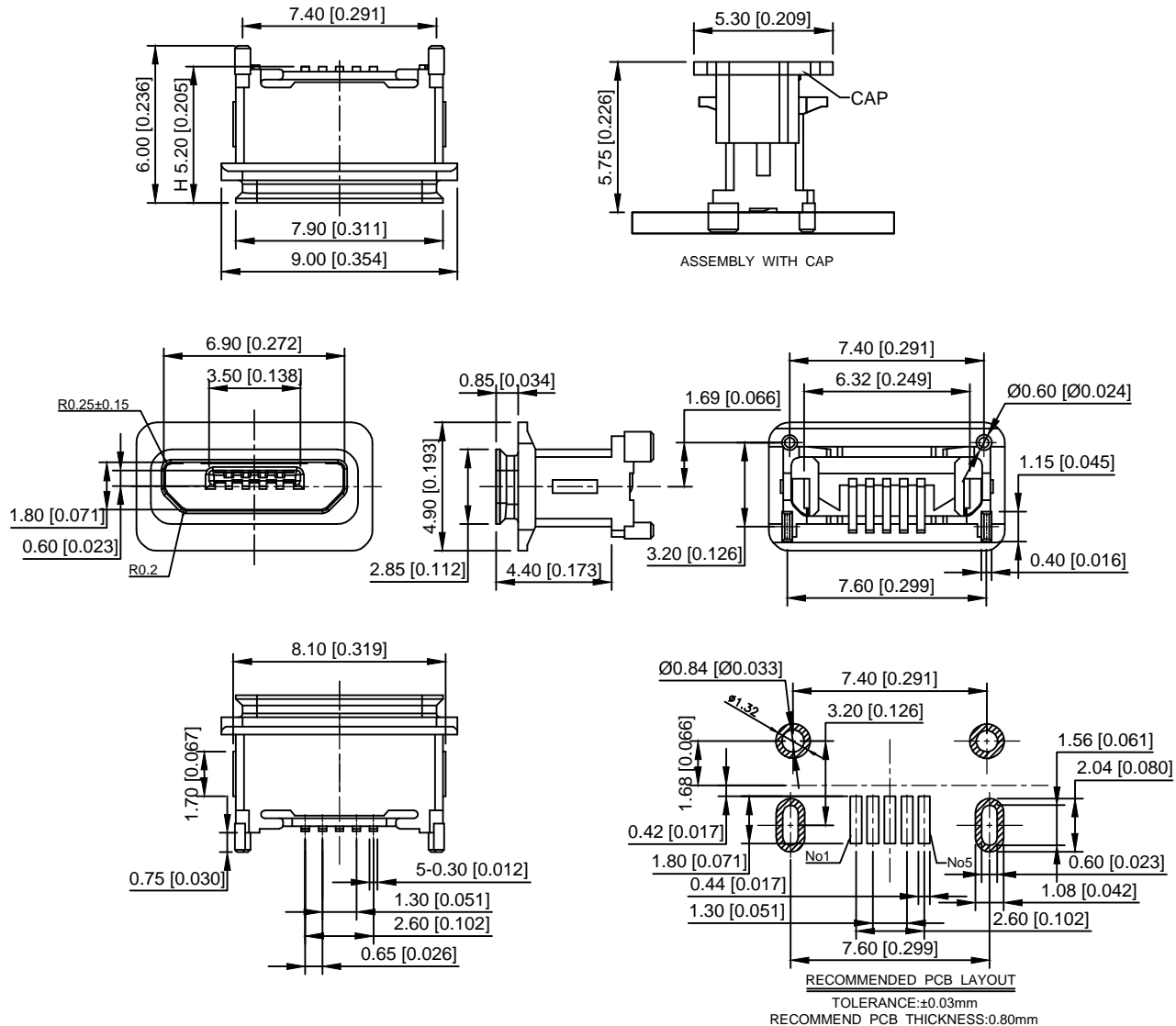

XKB Connectivity

- NOTES:
- MATERIAL:
 - HOUSING: THERMOPLASTIC HIGH-TEMP UL94V-0 BLACK COLOR.
 - CONTACT: COPPER ALLOY
 - SHELL: STAINLESS STEEL.
 - FINISH:
 - CONTACT: SEE TABLE 1.
 - OUT SHELL: 50u"Min. NICKEL ALL OVER
 - APPLIED TO IR SOLDERING PROCESS.
 - SPECIFICATION:
 - ELECTRICAL CHARACTERISTICS
 - CONTACT CURRENT RATING: Signal pin 1A, Power pin 1.8A
 - VOLTAGE RATING: 30V AC rms.
 - CONTACT RESISTANCE: 30mΩ MAX.
 - DIELECTRIC WITHSTANDING VOLTAGE: UNMATEP CONTACT 100V AC rms. 60MHZ FOR 1 MINUTE.
 - INSULATION RESISTANCE: 1000MQ MIN. 100V DC
 - TEMPERATURE RANGE: -30 TO +85
 - MECHANICAL:
 - INSERTION FORCE: 35N MAX.
 - WITHDRAWAL FORCE: 8N~25N.
 - DURABILITY: 10.000 CYCLES

U-E-M8SS-W-1
 1:G/F 2:5u" 3:10u"
 4:15u" 5:30u"

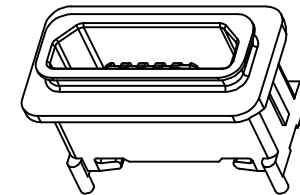

IP-X8

XKB Connectivity

MARK	DESCRIPTION	DATE	REVISED	APPROVED	UNSPECIFIED TOLERANCES
ΔX					ANGLAR ±5°
ΔX					L ≤ 4 ±0.2
ΔX					4 < L ≤ 16 ±0.3
					16 < L ≤ 63 ±0.4
					L > 63 ±0.5

DSND	DATE	SCALE: N/A	MODEL TYPE: MICRO USB
DWN	DATE	VIEW:	PART NO.: U-E-M8SS-W-1
CHKD	DATE	UNIT: mm/in	DWG NO.: U-E-M8SS-W-1
APPD	DATE	SIZE: A4	
XKB INDUSTRIAL PRECISION CO., LIMITED			WEIGHT 1.0g
			SHEET 1/1
			REVISION A0

XKB Connectivity

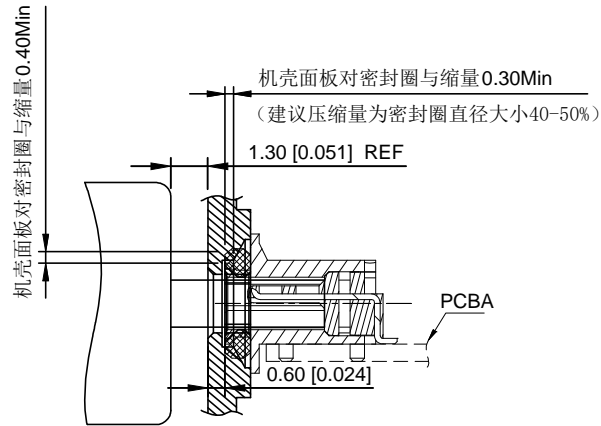

COMPRESSION RATIO TO BE 40%-50%

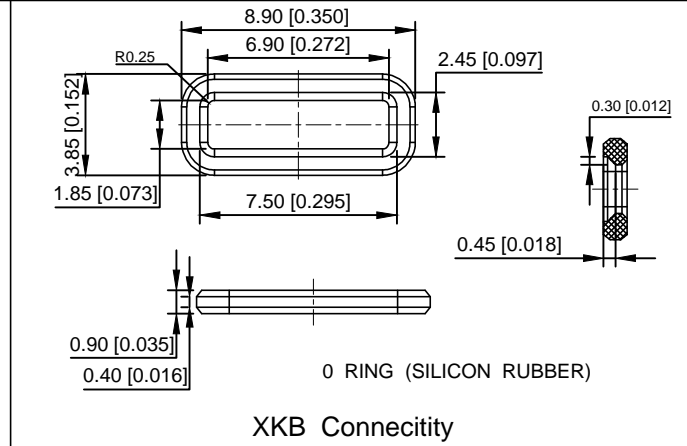
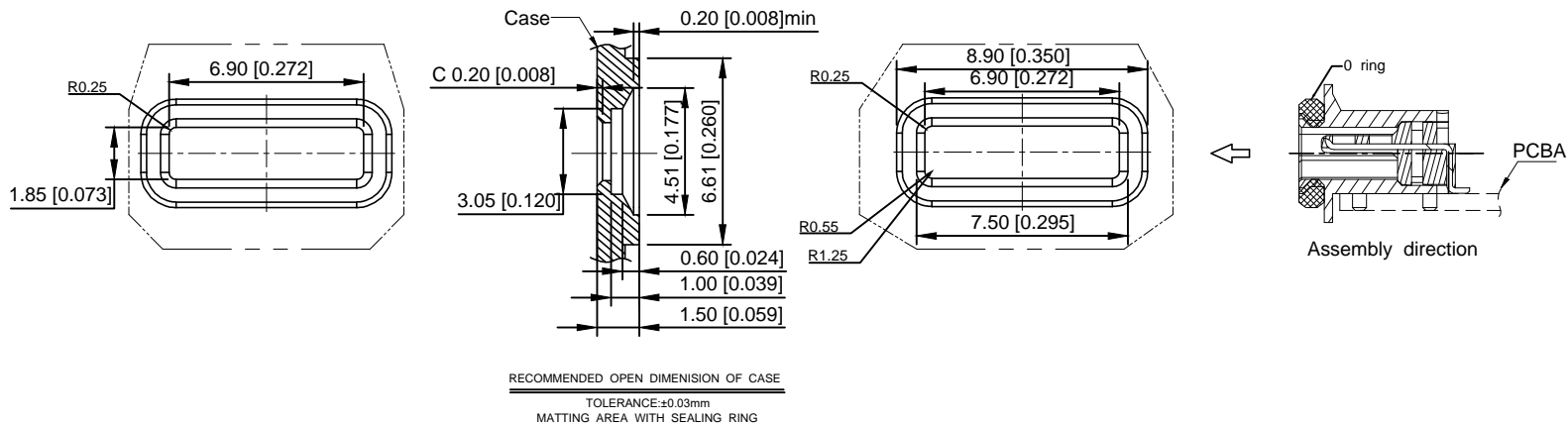

					DSND		DATE		SCALE: N/A	MODEL TYPE: MICRO USB			
ΔX					ANGLAR	±5°	DWN	DATE	VIEW:	PART NO.: U-E-M8SS-W-1			
ΔX					L ≤ 4	±0.2	CHKD	DATE	UNIT: mm/in	DWG NO.: U-E-M8SS-W-1			
ΔX					4 < L ≤ 16	±0.3	APPD	DATE	SIZE: A4				
MARK	DESCRIPTION	DATE	REVISED	APPROVED	16 < L ≤ 63	±0.4							
	REVISIONS				L > 63	±0.5							
					UNSPECIFIED TOLERANCES					XKB INDUSTRIAL PRECISION CO., LIMITED	WEIGHT 1.0g	SHEET 1/1	REVISION A0

单击下面可查看定价，库存，交付和生命周期等信息

[>>XKB Connectivity\(中国星坤\)](#)