

RECOMMEND P.C.B LAYOUT (COMPONENT SIDE)
TOLERANCE FOR PCB LAYOUT IS ± 0.05

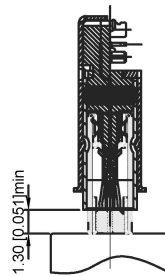

Material
Housing Material: High temperature thermoplastic
Contact Terminal: High Grade Copper Alloy
Metallic Shell: Stainless Steel
Cover Shell: Iron
Inner Ground Cover Shell: Stainless Steel
Mid Plate: Stainless Steel
Plating
Data Contact
Underplating: 50µ" Min. Nickel
Contact Plating: 1µ" Gold
Solder Area: 80µ" Matte Tin
Shell
Metallic Shell: 50µ" Min. Nickel
Cover Shell
Metallic Shell: 80µ" Min. Nickel
Inner Ground Cover Shell
Metallic Shell: 50µ" Min. Nickel
Electrical
Voltage Rating: 20V DC
Current Rating: Vbus pins collectively 5.00A, GND pins collectively 6.25A, B5 pin 1.25A, Other pins 0.25A per pin
Contact Resistance: 40mΩ Max.
Insulation resistance: 100 MΩ MIN.
Dielectric withstanding voltage: 100V AC/Minute
Mechanical
Durability: 10,000 cycles
Mating Force: 5 to 20N
Unmating Force: 8 to 20N (post test)

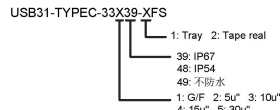
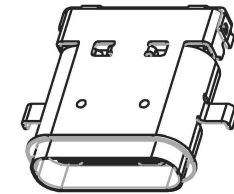
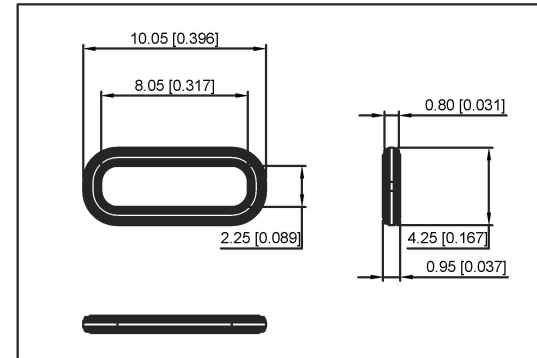

广东星坤科技股份有限公司

生效	日期
ΔX	
ΔX	
ΔX	

文件工程章

REVISIONS
www.hellokx.com www.hellokx.com

DSND	DATE	SCALE: N/A	MODEL TYPE: USB 3.1 TYPE
DWN	DATE	VIEW:	PART NO.:
CHKD	DATE	UNIT: mm/in	DWG NO.:
APPD	DATE	SIZE: A4	USB31-TYPEC-33X39-XFS
XKB INDUSTRIAL PRECISION CO., LIMITED			WEIGHT: 1.0g
			SHEET: 1/1
			REVISION: A0

单击下面可查看定价，库存，交付和生命周期等信息

[>>XKB Connectivity\(中国星坤\)](#)