



# 承 認 書

## SPECIFICATION FOR APPROVAL

客户名稱 CUSTOMER	
品名規格 DESCRIPTION	XRFS28*7.7*12-23*2.4
客户料號 CUS. P/N	
提出日期 DATE	July.02. 2019.
編 號 SERIAL NO.	

出 圖 DRAWING		
發行 MADE	復 核 CHECKED	確 認 APPROVED
		
DATE: 2019年07月02日		

承 認 CUSTOMER APPROVE



# 承認書

## SPECIFICATION FOR APPROVAL

客戶名稱 CUSTOMER		日期 DATE	2019.07.02.	
規格 ITEM	XRFS28*7.7*12-23*2.4	編號 SERIAL NO.		
1.1. 形狀尺寸(單位/毫米): SHAPE & DIMENSION(unit/mm):		1.2. 實物圖: The Sample::		
		A	28 ± 0.7 mm	
		B	7.7 ± 0.4 mm	
		C	23 ± 0.6 mm	
		D	12 ± 0.5 mm	
		E	2.4 ± 0.4 mm	
		F		
		G		
		H		
2. 電氣性能檢測項目: ELECTRICAL REQUIREMENTS:		測試儀器 TEST INSTRUMENTS		
<input type="checkbox"/> L		TEST FREQ	KHZ MHZ	
<input type="checkbox"/> Q		TEST FREQ	KHZ MHZ	
<input checked="" type="checkbox"/> Z	Z1= 25Ω MIN	KHZ 25 MHZ	Z2= 85Ω MIN	KHZ 100 MHZ
	Z3= /	KHZ MHZ	Z4= /	KHZ MHZ
溫度 TEMP	°C	濕度 HUMIDITY	%	
綫組 WINDING	Φ0.5x0.5TSx100L(mm)			
3. 外觀: THE LIMIT OF BREAKAGE:				
項目 Item		標準值 Standard Value		
一處缺陷的面積 Area of a breakage		≤2mm <sup>2</sup>		
總缺陷面積 All area of the breakage		≤2mm <sup>2</sup>		
缺陷深度 The depth of the breakage		≤0.4mm		
毛刺長度 The length of burr		≤0.2mm		
A	首版First Edition		2019-07-02	
版本Rev.	變更內容說明Description of Change		日期Date	
			Rosie	
			姓名Name	

# 檢驗數據

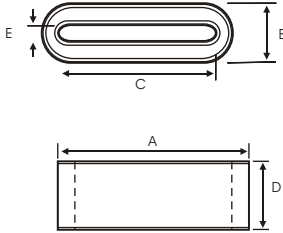
## INSPECTION DATA

客戶名稱 CUSTOMER			日期 DATE	2019.07.02.	數量 QUANTITY	10PCS
編號 SERIAL NO.			形狀尺寸(單位/毫米): SHAPE & DIMENSION(unit/mm):		實物圖: The Sample::	
規格 ITEM	XRFS28*7.7*12-23*2.4					
線組 WINDING	Φ0.5x0.5TSx100L(mm)					
測試頻率 TEST FREQ	Z1= 25 KHZ 25 MHZ	Z2= 100 KHZ 100 MHZ				
	Z3= / KHZ / MHZ	Z4= / KHZ / MHZ				
溫度 TEMP	℃	濕度 HUMIDITY				

項目 TEST ITEM	電氣性能 ELECTRIC CHARACTERISTICS						尺寸(單位:毫米) DIMENSION(unit:mm)					
	Q	L(μH) (MH)	Z1(Ω)	Z2(Ω)	Z3(Ω)	Z4(Ω)	A	B	C	D	E	F
			25	85			28	7.7	23	12	2.4	
+			/	/			0.7	0.4	0.6	0.5	0.4	
-			0	0			0.7	0.4	0.6	0.5	0.4	
1			35.2	105.6			27.91	7.68	22.78	11.78	2.50	
2			35.6	105.8			27.99	7.74	22.85	11.84	2.46	
3			35.8	105.0			27.98	7.73	22.89	11.83	2.48	
4			35.4	105.4			27.97	7.72	22.95	11.82	2.49	
5			36.6	105.2			28.11	7.59	22.93	11.75	2.47	
6			36.2	106.4			28.07	7.72	23.05	11.91	2.45	
7			36.4	106.2			28.13	7.76	23.14	11.93	2.48	
8			36.0	106.6			28.12	7.78	23.22	11.92	2.46	
9			35.6	106.0			28.07	7.71	23.15	11.94	2.52	
10			35.8	106.4			28.09	7.76	23.11	11.96	2.51	
$\bar{X}$			35.76	105.86			28.04	7.71	23.00	11.86	2.48	
Y/N			Y	Y			Y	Y	Y	Y	Y	

測試儀器:  
TEST INSTRUMENTS:  
HP 4191A

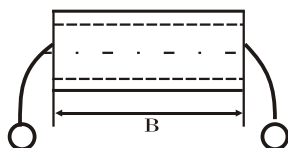

檢驗 INSPECTED	復核 CHECKED	確認 APPROVED
汪建琴		

A	首版First Edition	2019-07-02	Rosie
版本Rev.	變更內容說明Description of Change	日期Date	姓名Name

# 阻抗 - 頻率曲綫

## IMPEDANCE V.S FREQUENCY (Z-Y)

客戶名稱 CUSTOMER		日期 DATE	2019.07.02.
規格 ITEM	XRFS28*7.7*12-23*2.4	編號 SERIAL NO.	

### 材質特性 MATERIAL CHARACTERISTICS

材料牌號 Material	初始磁導率 Initial Permeability	比損耗因子 Relative Loss Factor	比溫度系數 Relative Temperature Coefficient	飽和磁通密度 Saturation Magnetic Flux Density	剩磁 Remanence	矯頑力 Coercivity	居裏溫度 Curie Temperature	電阻率 Electrical Resistivity	密度 Density
Unit symbol	$\mu_i$ $\pm 20\%$	$\tan \delta / \mu_i$ $\times 10^{-6}$	$\alpha \mu_i \gamma$ $\times 10^{-6}$	Bs (MT)	Br (MT)	HC (A/m)	Tc (°C)	$\rho$ ( $\Omega \cdot m$ )	d g/cm <sup>3</sup>
F9	850	16 (0.1MHz)	5 - 10	280(1600A/m)	200	20	>130	>10 <sup>5</sup>	4.6

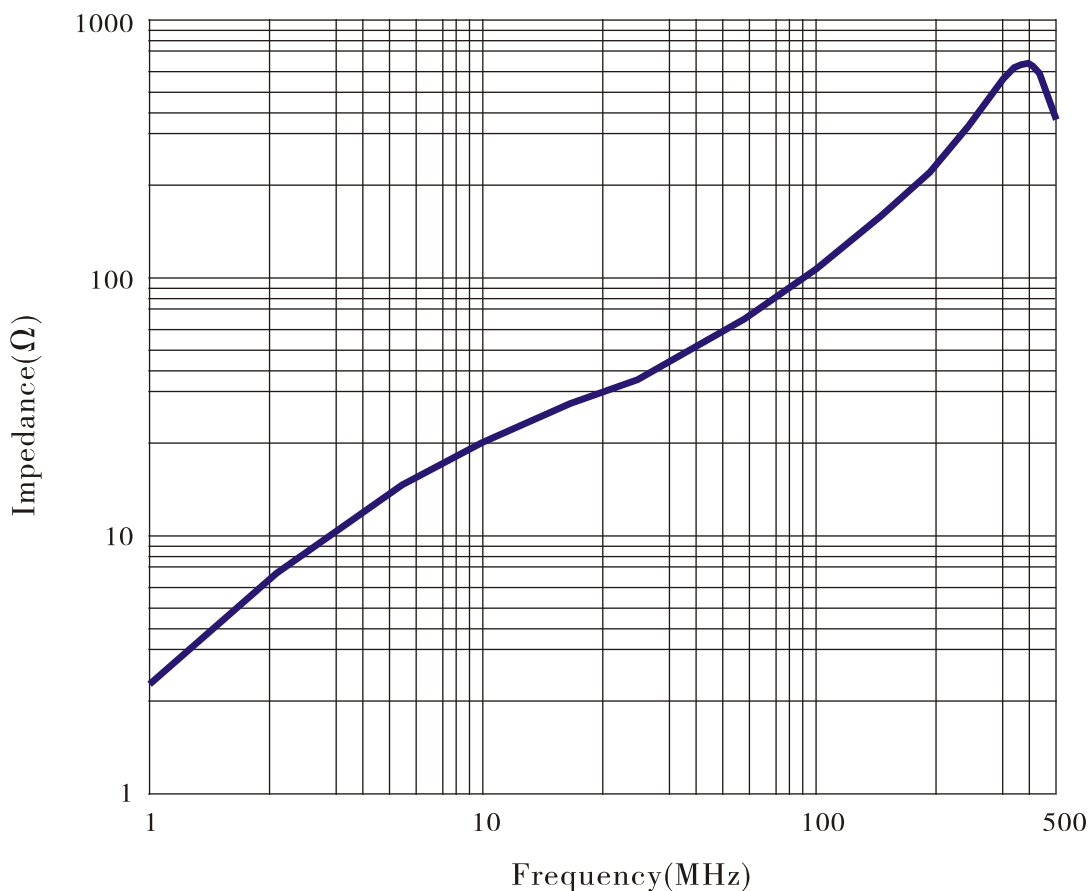

測試條件：  
TESTING CONDITION:

- |   |                     |
|---|---------------------|
| 1. 測試儀器：<br>Testing Equipment:          | HP 4191A            |
| 2. 測試頻率區間：<br>Testing Frequency Range:  | 1-500MHz            |
| 3. 測試綫組：<br>Testing Coil Specification: | Φ0.5x0.5TSx100L(mm) |

測試 TESTED	復核 CHECKED	確認 APPROVED
汪建琴	周 紀君	沈 學泉

A	首版First Edition	2019-07-02	Rosie
版本Rev.	變更內容說明Description of Change	日期Date	姓名Name

单击下面可查看定价，库存，交付和生命周期等信息

[>>XR\(祥如\)](#)