



东莞市祥如电子有限公司
DONGGUAN XIANGRU ELECTRONICS CO., LTD
产品承认书
SPECIFICATION FOR APPROVAL

客户名称: _____
CUSTOMER

我司料号: _____
OUR PART NO.

我司品名: _____
OUR PART NAME 立式工字电感

送样日期: 2023-02-09 数量: 0PCS
DATE SAMPLES QUANTITY

制造确认 MANUFACTURER APPROVE		
拟制 DRAWN	审核 CHECKED	确认 APPROVED
黄禾香	饶平	钟翠兰

客户确认 CUSTOMER APPROVE

客户名称 CUSTOMER NAME:

客户料号 CUSTOMER P/N:

规格型号 DESCRIPTION: XR4*6-2R2K-L

检查结果: 合格 不合格 签名及盖章:

INSPECT RESULT ACCEPT REJECT SIGNATURE AND STAMP

说明 REMARK:

如对本承认书内容有异议请提出或标记发送至我司，本承认书在未收到异议回复时于本承认书提供一周后生效。

东莞市祥如电子有限公司

地址: 广东省东莞市塘厦镇塘厦南二横路2号4号

电话: 0769-87988351 传真: 0769-87988471

网站: www.xiangrudz.com

东莞市祥如电子有限公司

DONGGUAN XIANGRU ELECTRONICS CO., LTD

产品承认书

SPECIFICATION FOR APPROVAL

客户名称 CUSTOMER		日期 DATE	2023-02-08
客户物料编号 CUSTOMER P/N		客户规格型号 DESCRIPTION	4*6-2.2UH 0.35线 长脚
我司物料编号 OUR PARTNO	XR4*6-2R2K-L	我司品名 OUR PART NAME	立式工字电感

外观尺寸 Appearance of size

单位 Unit: mm

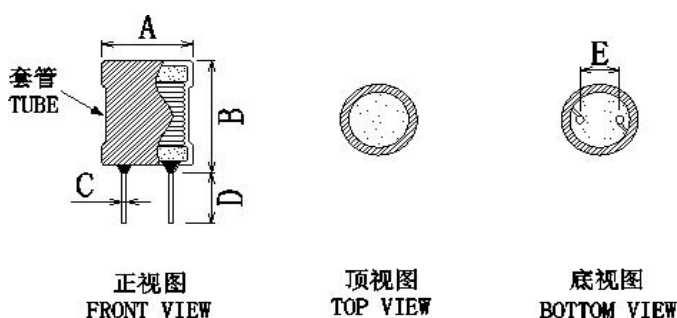

A	6.0 MAX	C	0.5±0.1	E	2.0±0.5		
B	8.5 MAX	D	15.0±2.0				
标识Identification							

原理图 Schematic Diagram

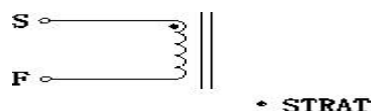

绕线结构表 Winding Structure Diagram

绕组 WINDING	起始 S	结束 F	漆包线 WIRE	圈数 TURNS		绕制方式 WINDINGWAY		
				10.5TS	圈数参考			
N1	S	F	2UEW-0.35mm	10.5TS	圈数参考	平整密绕		

注意事项 Matters needing attention:

用少字套管

东莞市祥如电子有限公司

DONGGUAN XIANGRU ELECTRONICS CO., LTD

产品承认书

SPECIFICATION FOR APPROVAL

客户名称 CUSTOMER		日期 DATE	2023-02-08
客户物料编号 CUSTOMER P/N		客户规格型号 DESCRIPTION	4*6-2.2UH 0.35线 长脚
我司物料编号 OUR PART NO	XR4*6-2R2K-L	我司品名 OUR PART NAME	立式工字电感

电性参数 Electrical parameters

测试项目 TEST PROJECT	电性范围 SPEC	测试条件 TEST FREQ	测试仪器 TEST STRUMENTS
电感量L	2.2uH±20%	at 25°C1KHz/0.25V	TH2829A
直流电阻DCR	50mΩ MAX	at 25°C1KHz/0.25V	TH2829A
饱和电流Isat	$L \geq L_0 * 90\%$	at 25°C DC1.5A 1KHz/0.25V	TH2829A

物料清单 BOM

物料 MATERIAL	规格型号 SPECIFICATIONS	制造厂商 MANUFACTURERS	UL证书号 UL FILE NO
CORE	MgZn DR2W4*6	HUAZHONG	
		OR Equivalent supplier	
WIRE	2UEW-F(QA)	GANYUE HENGXING	E233255
		OR Equivalent supplier	
PIN	Tinned copper clad steel wire	BAICHUAN	
		OR Equivalent supplier	
TUBE	UL HEAT-SHRINKABLE TUBE/125°C	XINGQI	E350991
		OR Equivalent supplier	
EPOXY RESIN	FK661	QI FU	
		OR Equivalent supplier	
SOLDER	Sn:99.3%/Cu:0.7%	SONGBEN	
		OR Equivalent supplier	

东莞市祥如电子有限公司

DONGGUAN XIANGRU ELECTRONICS CO., LTD

产品承认书

SPECIFICATION FOR APPROVAL

客户名称 CUSTOMER		日期 DATE	2023-02-08
客户物料编号 CUSTOMER P/N		客户规格型号 DESCRIPTION	4*6-2.2UH 0.35线 长脚
我司物料编号 OUR PARTNO	XR4*6-2R2K-L	我司品名 OUR PART NAME	立式工字电感

测试报告 The test report

测试项目 Test project	电性范围 Spec	测试数据 Test data				
		1	2	3	4	5
电感量L	2.2uH±20%	2.26	2.38	2.31	2.30	2.35
直流电阻DCR	50mΩ MAX	18	23	21	25	22
饱和电流Isat	L≥L0*90%	OK	OK	OK	OK	OK

测试室温/湿度: 室温: 25°C(REF) 相对湿度: 80%(REF)
 TEST CONDITIO EMP: 25°C(REF) R.H.: 80%(REF)

序号	项目	技术要求	结论
1	外观和尺寸	符合产品规范和公差要求	OK
2	引脚拉脱力	大于等于1Kg	OK
3			

制表 MADE	审核 CHECKED	批准 APPROVED	
黄禾香	饶平	钟翠兰	

东莞市祥如电子有限公司

DONGGUAN XIANGRU ELECTRONICS CO., LTD

产品承认书

SPECIFICATION FOR APPROVAL

注意事项

Matters needing attention

1、本公司产品适用于 AV 设备、OA 设备、家电、信息服务等一般电子设备中。

Our products are designed and promoted for use in general electronic devices such as audio-video equipment, office automation equipment, home appliance and information service.

2、当本公司的产品使用在一般电子设备以外的领域时，对于此所引发的设备失效我司将不承担任何法律责任。

In case of using the product for the purpose other than general electronics devices, we shall not be held liable for any dysfunctions in or damage to the equipment with which the product is used.

3、本承认书只保证我司产品作为一个单体时的质量情况，当我司产品被安装到贵司产品上时，请贵司对使用在贵司电路上的产品情况进行了有效评价和确认。

Our specification limits the quality of the component as a single unit. Please ensure the component is thoroughly evaluated in your application circuit.

4、不要对产品施加过大的振动或机械冲击；

Do not apply excessive vibration or mechanical shock to products.

5、为防止断线，请不要使用锋利的物体接触线圈，如镊子；

Do not touch wire with sharp objects such as tweezers to prevent wire breakage.

6、在产品贴装时不要使用过大的压力，避免磁芯断裂。

Do not apply excessive stress to products mounted on boards to prevent core breakage.

7、为保证端子电极的焊接特性和包装材料处于良好状态，请于本公司发货后 6 个月内使用本产品。同时，由于端子电极的焊接特性会随时间发生变化，如果贮存时间超过 6 个月，请首先确认其焊接特性后再安装使用。

To maintain the solderability of terminal electrodes and to keep the packing material in good condition, product should be used within 6 months from the time of delivery. And the solderability of products electrodes may decrease as time passes, so in case of storage over 6 months, solderability shall be checked before actual usage.

8、存放货物的仓库应满足以下条件 Store products in a warehouse in compliance with the following condition:

条件 Conditions	元件含包装物 Packing status	元件自身 Component itself
温度 Temperature	-25~+40°C	-25~+85°C
湿度 Humidity	30~70%RH	30~70%RH

9、不要使产品遭受温度和湿度的快速变化。

Do not subject products to rapid changes in temperature and humidity.

10、不要将产品存放在化学环境中，如硫酸气体或碱性气体中，否则会降低电极端子的焊接特性和使电感器腐蚀。

Do not store the products in chemical atmosphere such as one containing sulfurous acid gas or alkaline gas, that will causes poor solderability and corrosion of inductors.

11、为了避免受潮气、灰尘等物质的影响，产品应保管于货架上。

Store products on pallets to protect from humidity, dust, etc

12、产品应避免热冲击、振动以及直接光照等等。

Avoid heat shock, vibration, direct sunlight, etc.

单击下面可查看定价，库存，交付和生命周期等信息

[>>XR\(祥如\)](#)