

DATA SHEET

SURFACE MOUNT MULTILAYER CERAMIC CAPACITORS

Automotive grade
with Soft Termination

X7R

16 V to 250 V

1 nF to 4.7 μ F

RoHS compliant & Halogen Free



SCOPE

This specification describes Automotive grade X7R series chip capacitors with flexible lead-free terminations and used for automotive equipments.

APPLICATIONS

All general purpose applications
Entertainment applications
Comfort / security applications
Information applications

FEATURES

- AEC-Q200 qualified
- MSL class: MSL 1
- Soldering is compliant with J-STD-020D
- Increased mechanical performance
- High component and equipment reliability
- The capacitors are 100% performed by automatic optical inspection prior to taping.

ORDERING INFORMATION - GLOBAL PART NUMBER

All part numbers are identified by the series, size, tolerance, TC material, packing style, voltage, process code, termination and capacitance value.

GLOBAL PART NUMBER

AS XXXX X X XXX X **B** X XXX
(1) (2) (3) (4) (5) (6) (7)

(1) SIZE – INCH BASED (METRIC)

0603 (1608) / 0805 (2012) / 1206 (3216) / 1210 (3225)

(2) TOLERANCE

J = ±5%

K = ±10%

M = ±20%

(3) PACKING STYLE

R = Paper/PE taping reel; Reel 7 inch

K = Blister taping reel; Reel 7 inch

P = Paper/PE taping reel; Reel 13 inch

F = Blister taping reel; Reel 13 inch

(4) TC MATERIAL

X7R

(5) RATED VOLTAGE

7 = 16 V

8 = 25 V

9 = 50 V

0 = 100 V

A = 200 V

Y = 250 V

(6) PROCESS

B = Class 2 MLCC

(7) CAPACITANCE VALUE

2 significant digits + number of zeros

The 3rd digit signifies the multiplying factor, and letter R is decimal point

Example: 121 = $12 \times 10^1 = 120 \text{ pF}$

CONSTRUCTION

The capacitor consists of a rectangular block of ceramic dielectric in which a number of interleaved metal electrodes are contained. This structure gives rise to a high capacitance per unit volume.

The inner electrodes are connected to the two end flexible terminations and finally covered with a layer of plated tin (NiSn).

The terminations are lead-free. A cross section of the structure is shown in Fig.1 and Fig.2.

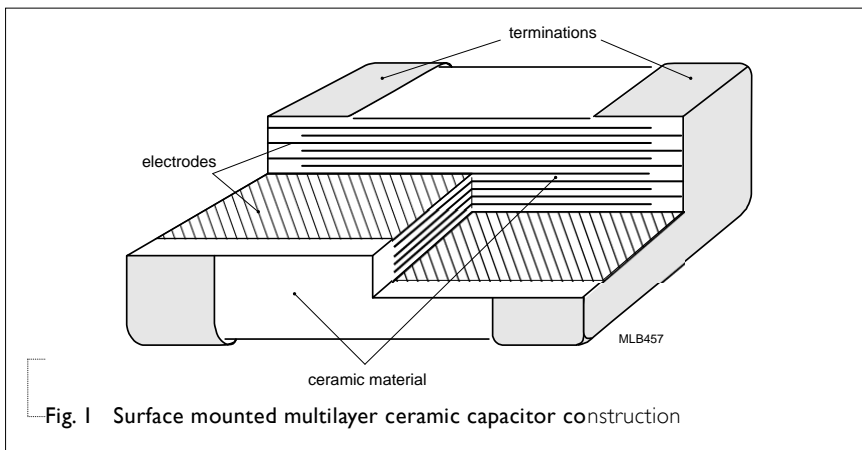
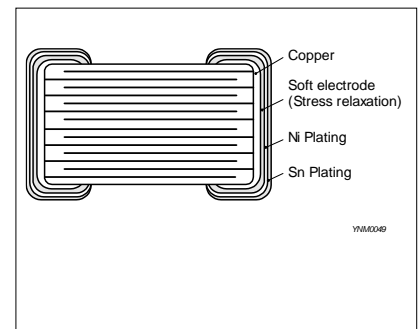

Fig. 1 Surface mounted multilayer ceramic capacitor construction



DIMENSION

Table I For outlines see fig. 3

TYPE	L1 (mm)	W (mm)	T (mm)	L2/L3(mm) min	L2/L3(mm) max	L4(mm) min
0603	1.6 ± 0.2	0.8 ± 0.15	0.8 ± 0.15	0.20	0.65	0.50
0805	2.0 ± 0.3	1.25 ± 0.2	0.85 ± 0.15	0.25	0.75	0.70
			1.25 ± 0.20			
1206	3.2 ± 0.4	1.6 ± 0.2	0.85 ± 0.15	0.25	0.85	1.50
			1.25 ± 0.20			
			1.60 ± 0.20			
1210	3.2 ± 0.5	2.5 ± 0.3	2.5 ± 0.3	0.25	1.00	1.20

OUTLINES

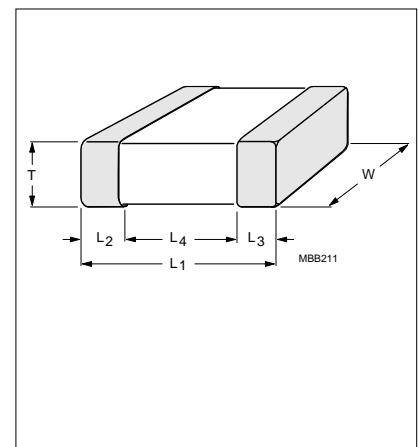

CAPACITANCE RANGE & THICKNESS FOR X7R

Table 2 Size 0805

CAP.	0603				0805		
	16 V	25 V	50 V	100 V	25 V	50 V	100 V
1.0 nF	0.8±0.15	0.8±0.15	0.8±0.15	0.8±0.15	0.85±0.15	0.85±0.15	0.85±0.15
1.5 nF	0.8±0.15	0.8±0.15	0.8±0.15	0.8±0.15	0.85±0.15	0.85±0.15	0.85±0.15
2.2 nF	0.8±0.15	0.8±0.15	0.8±0.15	0.8±0.15	0.85±0.15	0.85±0.15	0.85±0.15
3.3 nF	0.8±0.15	0.8±0.15	0.8±0.15	0.8±0.15	0.85±0.15	0.85±0.15	0.85±0.15
4.7 nF	0.8±0.15	0.8±0.15	0.8±0.15	0.8±0.15	0.85±0.15	0.85±0.15	0.85±0.15
6.8 nF	0.8±0.15	0.8±0.15	0.8±0.15	0.8±0.15	0.85±0.15	0.85±0.15	0.85±0.15
10 nF	0.8±0.15	0.8±0.15	0.8±0.15	0.8±0.15	0.85±0.15	0.85±0.15	0.85±0.15
15 nF	0.8±0.15	0.8±0.15	0.8±0.15	0.8±0.15	0.85±0.15	0.85±0.15	0.85±0.15
22 nF	0.8±0.15	0.8±0.15	0.8±0.15	0.8±0.15	0.85±0.15	0.85±0.15	0.85±0.15
33 nF	0.8±0.15	0.8±0.15	0.8±0.15	0.8±0.15	0.85±0.15	0.85±0.15	1.25±0.2
47 nF	0.8±0.15	0.8±0.15	0.8±0.15	0.8±0.15	0.85±0.15	0.85±0.15	1.25±0.2
68 nF	0.8±0.15	0.8±0.15	0.8±0.15		1.25±0.2	1.25±0.2	1.25±0.2
100 nF	0.8±0.15	0.8±0.15	0.8±0.15		1.25±0.2	1.25±0.2	1.25±0.2
1 µF					1.25±0.2		

NOTE

Values in shaded cells indicate thickness class in mm

CAPACITANCE RANGE & THICKNESS FOR X7R

Table 3 Size 1206

CAP.	1206					1210			
	16V	25V	50 V	100 V	200 V / 250 V	50V	100V	200 V	250 V
22 nF					1.25±0.2				
33 nF					1.25±0.2				
47 nF					1.25±0.2				
68 nF					1.25±0.2				
100 nF	0.85±0.15	0.85±0.15	1.25±0.2	1.6±0.2		1.25±0.2	1.25±0.2	1.25±0.2	
150 nF	1.25±0.2	1.25±0.2	1.25±0.2			1.25±0.2	1.25±0.2	1.25±0.2	
220 nF	1.25±0.2	1.25±0.2	1.25±0.2	1.25±0.2		1.25±0.2	1.25±0.2	1.25±0.2	
4.7 uF						2.5±0.3			

NOTE

Values in shaded cells indicate thickness class in mm

THICKNESS CLASSES AND PACKING QUANTITY

Table 5

SIZE CODE	THICKNESS CLASSIFICATION	TAPE WIDTH QUANTITY PER REEL	Ø180 MM / 7 INCH		Ø330 MM / 13 INCH	
			Paper	Blister	Paper	Blister
0603	0.8 ±0.15 mm	8 mm	4,000	---	15,000	---
0805	0.85 ±0.15 mm	8 mm	4,000	---	15,000	---
	1.25 ±0.2 mm	8 mm	---	3,000	---	10,000
1206	0.6 ±0.1 mm	8 mm	4,000	---	20,000	---
	0.85 ±0.1 mm	8 mm	4,000	---	15,000	---
	1.25 ±0.2 mm	8 mm	---	3,000	---	10,000
	1.6 ±0.2 mm	8 mm	---	2,000	---	10,000
1210	2.5 ±0.3 mm	8 mm	---	1,000	---	---

ELECTRICAL CHARACTERISTICS

NP0/X7R DIELECTRIC CAPACITORS; NI/SIN TERMINATIONS

Unless otherwise specified, all test and measurements shall be made under standard atmospheric conditions for testing as given in 5.3 of IEC 60068-1:

- Temperature: 15 °C to 35 °C
- Relative humidity: 25% to 75%
- Air pressure: 86 kPa to 106 kPa

Before the measurements are made, the capacitor shall be stored at the measuring temperature for a time sufficient to allow the entire capacitor to reach this temperature.

The period as prescribed for recovery at the end of a test is normally sufficient for this purpose.

Table 6

DESCRIPTION		VALUE				
Capacitance range		1 nF to 4.7 uF				
Capacitance tolerance						
X7R		±5% ⁽¹⁾ , ±10%, ±20%				
Dissipation factor (D.F.)						
X7R		0603	0805	1206	1210	
	16V	1nF to 100nF		220nF		≤ 3.5%
	25V	1nF to 39nF	1nF to 100nF	100nF to 220nF		≤ 2.5%
		47nF to 100nF				≤ 3.5%
			1 μF			≤ 5%
	50V	1nF to 39nF	1nF to 100nF	100nF to 220nF		≤ 2.5%
		47nF to 100nF				≤ 3.5%
					4.7 uF	≤ 10%
	100V	1nF to 10nF	1nF to 100nF	100nF to 220nF		≤ 2.5%
		12nF to 47nF				≤ 5%
	200V / 250V			22nF to 100nF		≤ 2.5%
Insulation resistance after 1 minute at U _r (DC)		IR ≥ 10 GΩ or I.R × C ≥ 500Ω.F whichever is less				
Maximum capacitance change as a function of temperature (temperature characteristic/coefficient):						
X7R		±15%				
Operating temperature range:						
X7R		-55 °C to +125 °C				

NOTE

1. Capacitance tolerance ±5% doesn't available for X7R full product range, please contact local sales force before order

SOLDERING RECOMMENDATION

Table 7

SOLDERING METHOD	SIZE 0402	0603	0805	1206	≥ 1210
Reflow	≥ 0.1 μF	≥ 1.0 μF	≥ 2.2 μF	≥ 4.7 μF	Reflow only
Reflow/Wave	< 0.1 μF	< 1.0 μF	< 2.2 μF	< 4.7 μF	---

SOLDERING CONDITIONS

The lead free MLCCs are able to stand the reflow soldering conditions as below:

- Temperature: above 220 °C
- Endurance: 95 to 120 seconds
- Cycles: 3 times

The test of "soldering heat resistance" is carried out in accordance with the schedule of "MIL-STD-202G-method 210F", "The robust construction of chip capacitors allows them to be completely immersed in a solder bath of 260 °C for 10 seconds". Therefore, it is possible to mount MLCCs on one side of a PCB and other discrete components on the reverse (mixed PCBs). Surface Mount Capacitors are tested for solderability at 245 °C during 2 seconds. The test condition for no leaching is 260°C for 30 seconds.

TESTS AND REQUIREMENTS

Table 8 Test procedures and requirements

TEST	TEST METHOD	PROCEDURE	REQUIREMENTS
Mounting	IEC 60384-21/22 4.3	The capacitors may be mounted on printed-circuit boards or ceramic substrates	No visible damage
Capacitance	IEC 60384-21/22 4.5.1	At 20°C, 24 hours after annealing f = 1 KHz, measuring at voltage $1 V_{rms}$ at 20°C	Within specified tolerance
Dissipation Factor (D.F.)	IEC 60384-21/22 4.5.2	At 20 °C, 24 hours after annealing f = 1 KHz, measuring at voltage $1 V_{rms}$ at 20°C	In accordance with specification
Insulation Resistance	IEC 60384-21/22 4.5.3	At U_r (DC) for 1 minute	In accordance with specification

TEST	TEST METHOD	PROCEDURE	REQUIREMENTS
High Temperature Exposure	AEC-Q200 3	Unpowered ; 1000hours @ T=150°C Measurement at 24±2 hours after test conclusion.	No visual damage ΔC/C : X7R: ±10% D.F.: within initial specified value IR: within initial specified value
Temperature Cycling	AEC-Q200 4	Preconditioning: 150 +0/-10°C for 1 hour, then keep for 24 ±1 hours at room temperature 1000 cycles with following detail: 30 minutes at lower category temperature 30 minutes at upper category temperature Recovery time 24 ±2 hours	No visual damage ΔC/C X7R: ±10% D.F. meet initial specified value IR meet initial specified value
Destructive Physical Analysis	AEC-Q200 5	Note: Only applies to SMD ceramics. Electrical test not required.	
Moisture Resistance	AEC-Q200 6	T=24 hrs/per cycle; 10 continuous cycles unpowered. Measurement at 24 ±2 hours after test condition.	No visual damage ΔC/C X7R: ±10% D.F. Within initial specified value IR X7R: Meet initial specified value

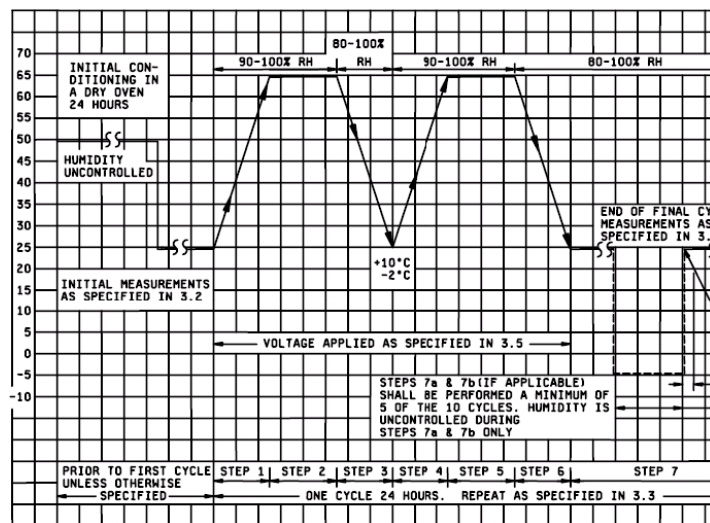
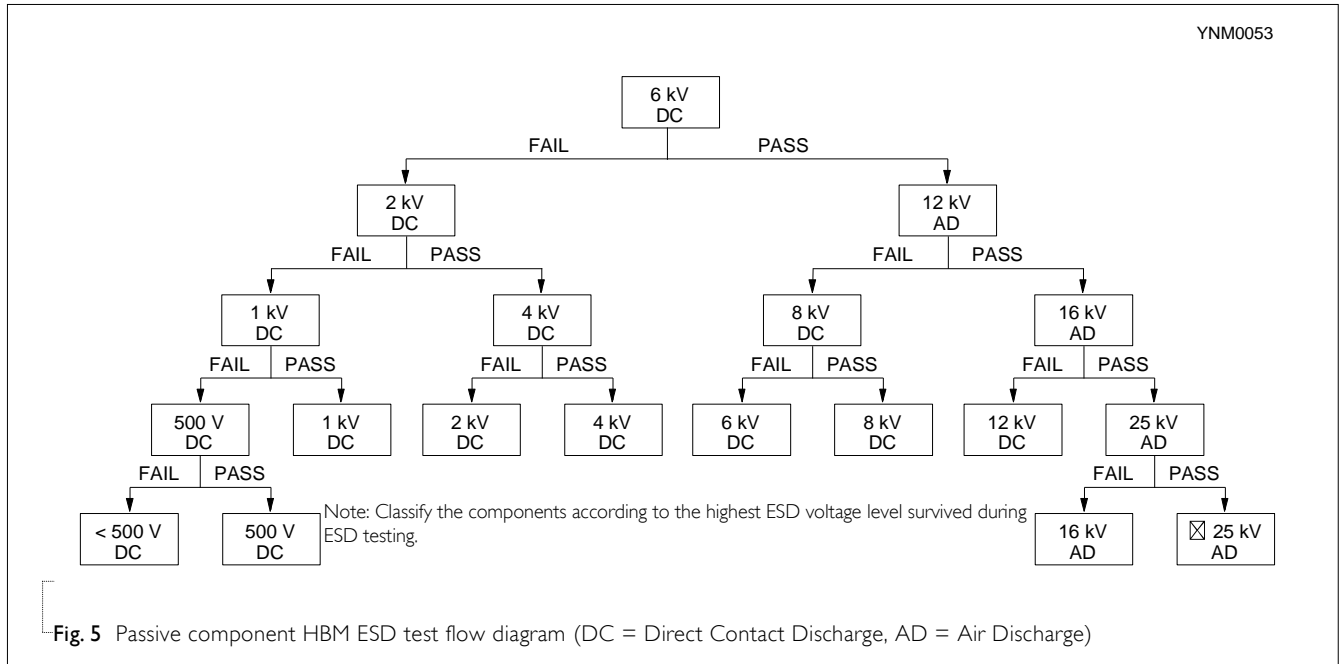

Fig. 4 Moisture resistant

TEST	TEST METHOD		PROCEDURE	REQUIREMENTS
Biased Humidity	AEC-Q200	7	1. Preconditioning, class 2 only: 150 +0/-10 °C /1 hour, then keep for 24 ±1 hour at room temp	No visual damage after recovery
			2. Initial measure: Parameter: Cap, D.F., I.R. Measuring voltage: 1.5V ± 0.1 VDC Note: Series with 100 KΩ	ΔC/C X7R: ±15% D.F. Less than 200% of initial spec.
			3. Test condition: 85 °C, 85% R.H. connected with 100 KΩ resistor, applied 1.5V/Ur for 1,000 hours.	I.R. The insulation resistance shall greater than 10% of initial spec.
			4. Recovery: Class2: 24 ±2 hours	
			5. Final measure: Cap, D.F., I.R.	
Operational Life	AEC-Q200	8	1. Preconditioning, class 2 only: 150 +0/-10 °C /1 hour, then keep for 24 ±1 hour at room temp	No visual damage
			2. Initial measure: Spec: refer to initial spec C, D, IR	ΔC/C X7R: ±15%
			3. Endurance test: Temperature: X7R: 125 °C Specified stress voltage applied for 1,000 hours: Applied 2.0 × Ur for general products Applied 1.5 × Ur for high cap. Products High voltage series follows with below stress condition: Applied 1.5 × Ur for 200V, 250V series	D.F. Less than 200% of initial spec. IR The insulation resistance shall be greater than 10% of initial spec.
			4. Recovery time: 24 ±2 hours	
			5. Final measure: C, D, IR Note: If the capacitance value is less than the minimum value permitted, then after the other measurements have been made the capacitor shall be preconditioned according to "IEC 60384 4.1" and then the requirement shall be met.	
External Visual	AEC-Q200	9	Any applicable method using × 10 magnification	In accordance with specification
Physical Dimension	AEC-Q200	10	Verify physical dimensions to the applicable device specification.	In accordance with specification
Mechanical Shock	AEC-Q200	13	Three shocks in each direction shall be applied along the three mutually perpendicular axes of the test specimen (18 shocks)	ΔC/C X7R: ±10%
			Peak value: 1,500 g's	
			Duration: 0.5 ms	D.F.
			Velocity change: 15.4 ft/s	Within initial specified value
			Waveform: Half-sin	IR Within initial specified value

TEST	TEST METHOD	PROCEDURE	REQUIREMENTS
Vibration	AEC-Q200 14	5 g's for 20 minutes, 12 cycles each of 3 orientations. Note: Use 8" x 5" PCB, 0.31" thick 7 secure points on one long side and 2 secure points at corners of opposite sides. Parts mounted within 2" from any secure point. Test from 10-2000 Hz.	$\Delta C/C$ X7R: $\pm 10\%$ D.F: meet initial specified value IR meet initial specified value
Resistance to Soldering Heat	AEC-Q200 15	Precondition: 150 +0/-10 °C for 1 hour, then keep for 24 \pm 1 hours at room temperature Preheating: for size \leq 1206: 120 °C to 150 °C for 1 minute Preheating: for size >1206: 100 °C to 120 °C for 1 minute and 170 °C to 200 °C for 1 minute Solder bath temperature: 260 \pm 5 °C Dipping time: 10 \pm 0.5 seconds Recovery time: 24 \pm 2 hours	Dissolution of the end face plating shall not exceed 25% of the length of the edge concerned $\Delta C/C$ Class2: X7R: $\pm 10\%$ D.F. within initial specified value IR within initial specified value
Thermal Shock	AEC-Q200 16	1. Preconditioning, class 2 only: 150 +0/-10 °C /1 hour, then keep for 24 \pm 1 hour at room temp 2. Initial measure: Spec: refer to initial spec C, D, IR 3. Rapid change of temperature test: -55 °C to +125 °C; 300 cycles 15 minutes at lower category temperature; 15 minutes at upper category temperature. 4. Recovery time: Class 2: 24 \pm 2 hours 5. Final measure: C, D, IR	No visual damage $\Delta C/C$ X7R: $\pm 15\%$ D.F: meet initial specified value IR meet initial specified value

TEST	TEST METHOD	PROCEDURE	REQUIREMENTS
ESD	AEC-Q200 17	Per AEC-Q200-004	A component passes a voltage level if all components stressed at that voltage level pass.



Solderability	AEC-Q200 18	<ol style="list-style-type: none"> Preheat at 155°C for 4 hours. After preheating, immerse the capacitor in a solution of ethanol and rosin (25% rosin in weight proportion). Immerse in eutectic solder solution for 5+0/-0.5 seconds at 235±5°C. Should be placed into steam aging for 8 hours±15 minutes. After preheating, immerse the capacitor in a solution of ethanol and rosin (25% rosin in weight proportion). Immerse in eutectic solder solution for 5+0/-0.5 seconds at 235±5°C. Should be placed into steam aging for 8 hours±15 minutes. After preheating, immerse the capacitor in a solution of Ethanol and rosin (25% rosin in weight proportion). Immerse in eutectic solder solution for 120±5 seconds at 260±5°C. 	The solder should cover over 95% of the critical area of each termination.
----------------------	-------------	--	--

Electrical Characterization	AEC-Q200 19	Parametrically test per lot and sample size requirements, summary to show Min, Max, Mean and Standard deviation at room as well as Min and Max operating temperatures. X7R: -55 °C to +125 °C Normal temperature: 20 °C	ΔC/C Class2: X7R: ±15%
------------------------------------	-------------	---	------------------------------

TEST	TEST METHOD	PROCEDURE	REQUIREMENTS
Board Flex	AEC-Q200 21	Part mounted on a 100 mm X 40 mm FR4 PCB board, which is 1.6 ±0.2 mm thick and has a layer-thickness 35 µm ± 10 µm. Part should be mounted using the following soldering reflow profile. Conditions: Class2: Bending 5 mm at a rate of 1 mm/s, radius jig 230 mm	No visible damage $\Delta C/C$ Class2: X7R: ±10%

Test Substrate:

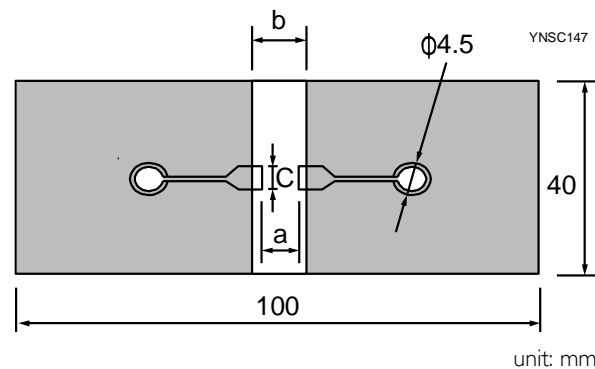

Type	Dimension(mm)		
	a	b	c
0201	0.3	0.9	0.3
0402	0.4	1.5	0.5
0603	1.0	3.0	1.2
0805	1.2	4.0	1.65
1206	2.2	5.0	1.65
1210	2.2	5.0	2.0
1808	3.5	7.0	3.7

Terminal Strength	AEC-Q200 22	With the component mounted on a PCB obtained with the device to be tested, apply a 17.7N (1.8Kg) force to the side of a device being tested. This force shall be applied for 60+1 seconds. Also the force shall be applied gradually as not to apply a shock to the component being tested. * Apply 2N force for 0402 size.	Magnification of 20X or greater may be employed for inspection of the mechanical integrity of the device body, terminals and body/terminal junction. Before and after the test, the device shall comply with all electrical requirements stated in this specification.
-------------------	-------------	--	---

Beam Load Test	AEC-Q200 23	Place the part in the beam load fixture. Apply a force until the part breaks or the minimum acceptable force level required in the user specification(s) is attained.	≤ 0805 Thickness > 0.5 mm: 20N Thickness ≤ 0.5 mm: 8N ≥ 1206 Thickness ≥ 1.25 mm: 54N Thickness < 1.25 mm: 15N
----------------	-------------	---	---

Voltage Proof	IEC 60384-1 4.6	Specified stress voltage applied for 1~5 seconds $U_r \leq 100 V$: series applied 2.5 U_r $100 V < U_r \leq 200 V$ series applied (1.5 $U_r + 100$) $200 V < U_r \leq 500 V$ series applied (1.3 $U_r + 100$) Charge/Discharge current is less than 50mA	No breakdown or flashover
---------------	-----------------	---	---------------------------

REVISION HISTORY

REVISION	DATE	CHANGE NOTIFICATION	DESCRIPTION
Version 3	Nov. 28, 2022	-	- Update Biased Humidity and operation life requirements.
Version 2	Dec. 21, 2020	-	- Add X7R product range, 0603, 1nF to 15nF, 16 to 100V
Version 1	Dec. 04, 2018	-	- Add 0603/ 22nF to 100nF
Version 0	Oct. 05, 2017	-	- New

LEGAL DISCLAIMER

YAGEO, its distributors and agents (collectively, "YAGEO"), hereby disclaims any and all liabilities for any errors, inaccuracies or incompleteness contained in any product related information, including but not limited to product specifications, datasheets, pictures and/or graphics. YAGEO may make changes, modifications and/or improvements to product related information at any time and without notice.

YAGEO makes no representation, warranty, and/or guarantee about the fitness of its products for any particular purpose or the continuing production of any of its products. To the maximum extent permitted by law, YAGEO disclaims (i) any and all liability arising out of the application or use of any YAGEO product, (ii) any and all liability, including without limitation special, consequential or incidental damages, and (iii) any and all implied warranties, including warranties of fitness for a particular purpose, non-infringement and merchantability.

YAGEO statements regarding the suitability of products for certain types of applications are based on YAGEO's knowledge of typical operating conditions for such types of applications in a generic nature. Such statements are neither binding statements of YAGEO nor intended to constitute any warranty concerning the suitability for a specific customer application or use. They are intended for use only by customers with requisite knowledge and experience for determining whether YAGEO products are the correct products for their application or use. In addition, unpredictable and isolated cases of product failure may still occur, therefore, customer application or use of YAGEO products which requires higher degree of reliability or safety, shall employ additional protective safeguard measures to ensure that product failure would not result in personal injury or property damage.

YAGEO products are not designed for application or use in medical, life-saving, or life-sustaining devices or for any other application or use in which the failure of YAGEO products could result in personal injury or death. Customers using or selling YAGEO products not expressly indicated for above-mentioned purposes shall do so at their own risk and agree to fully indemnify YAGEO and hold YAGEO harmless.

Information provided here is intended to indicate product specifications only. YAGEO reserves all the rights for revising this content without further notification, as long as products are unchanged. Any product change will be announced by PCN.

单击下面可查看定价，库存，交付和生命周期等信息

[>>Yageo\(国巨\)](#)