

# DATA SHEET

WIRELESS COMPONENTS

Ceramic Chip Antenna

ANT3216LL05R5000A

5 GHz

3216 Series



FEATURES

- Compact size
- Omni-directional radiation
- Tape & reel automatic mounting
- Reflow process compatible
- RoHS compliant

APPLICATIONS

- ISM band equipment

ORDERING INFORMATION

All part numbers are identified by the series, packing type, material, size, antenna type, working frequency and packing quantity.

**PART NUMBER**

**ANT 3216 L L05 R 5000A**

(1) (2) (3) (4) (5) (6)

---

**(1) PRODUCT**

ANT = Antenna

---

**(2) SIZE**

3216 = 3.2 × 1.6 mm

---

**(3) ANTENNA TYPE**

L,F,A = Chip Antenna

---

**(4) SERIAL NO.**

L05

---

**(5) PACKING TYPE**

R = Tape and Reel

---

**(6) WORKING FREQUENCY**

5000 = 5 GHz

---

**PHYCOMP CTC**

CAN4311712055003K

---

**I2NC**

431171205500

---

**SPECIFICATION**

Table 1

DESCRIPTION	VALUE
Working Frequency	5.5 GHz
Bandwidth	> 1000M Hz (Typ.)
Return Loss	10 dB min
Polarization	Linear
Azimuth Beamwidth	Omni-directional
Peak Gain	5.71 dBi (Typ.)
Impedance	50Ω
Operating Temperature	-40~105°C
Maximum Power	1W
Termination	Ni / Sn (Environmentally-Friendly Leadless)
Resistance to Soldering Heats	260°C , 10sec.

**NOTE**

I. The specification is defined on Yageo evaluation board

**DIMENSIONS**

Table 2 Machinical Dimension

	DIMENSION
L (mm)	3.20 ±0.15
W (mm)	1.60 ±0.15
T (mm)	1.20 ±0.10
C (mm)	0.30 ±0.20

Table 3 Termination configuration

TERMINAL NAME	FUNCTION
S1	Feeding Point
S2	Soldering Point

**OUTLINES**

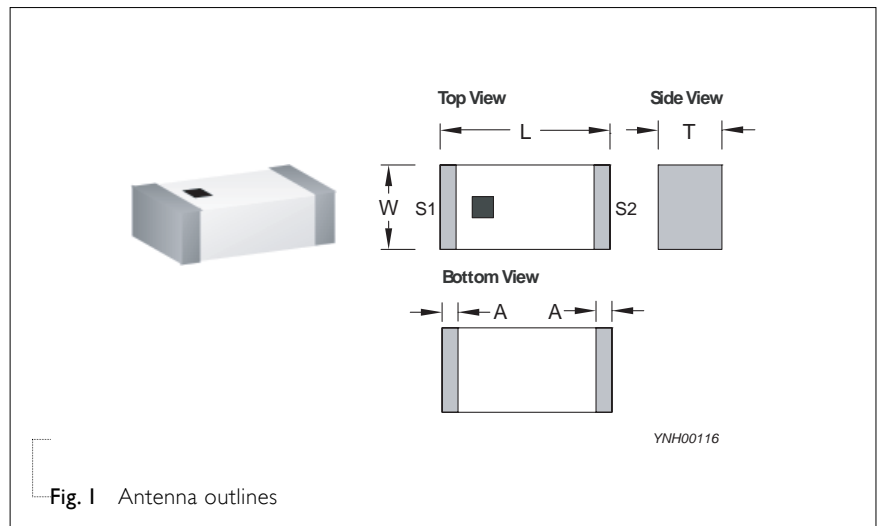
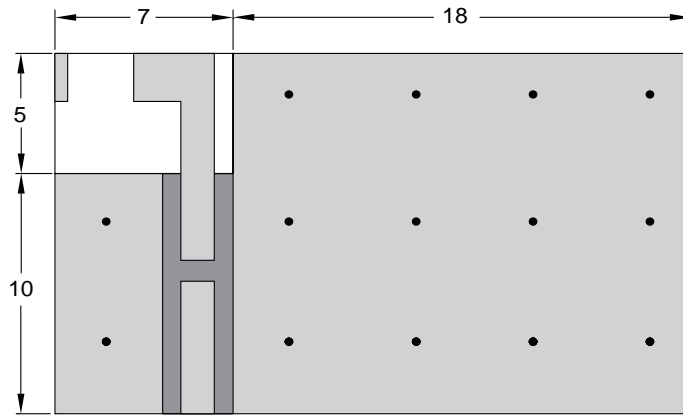

Fig. 1 Antenna outlines

**REFERENCE DESIGN OF EVALUATION BOARD**



Unit : mm

**Fig. 2** Outlook and dimension of evaluation board

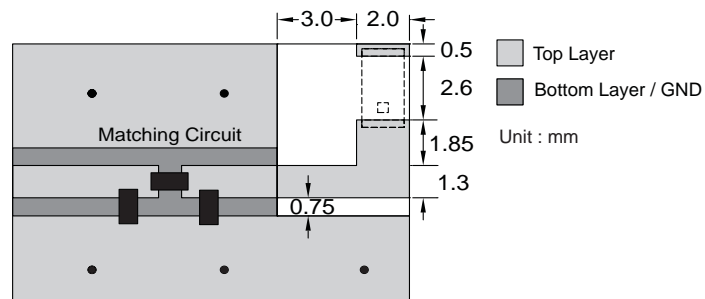

YNH00117

**Fig. 3** Details of soldering Pad

**ELECTRICAL PERFORMANCES**

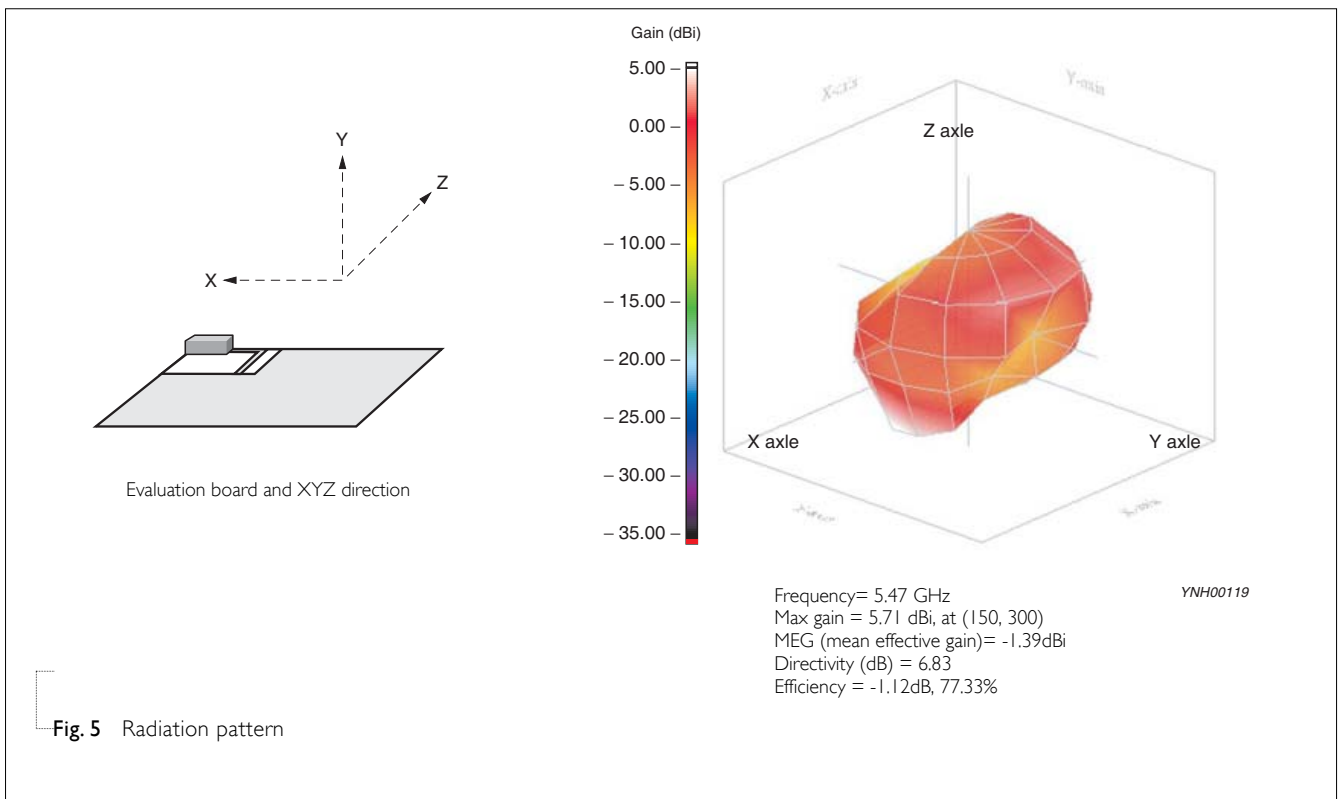
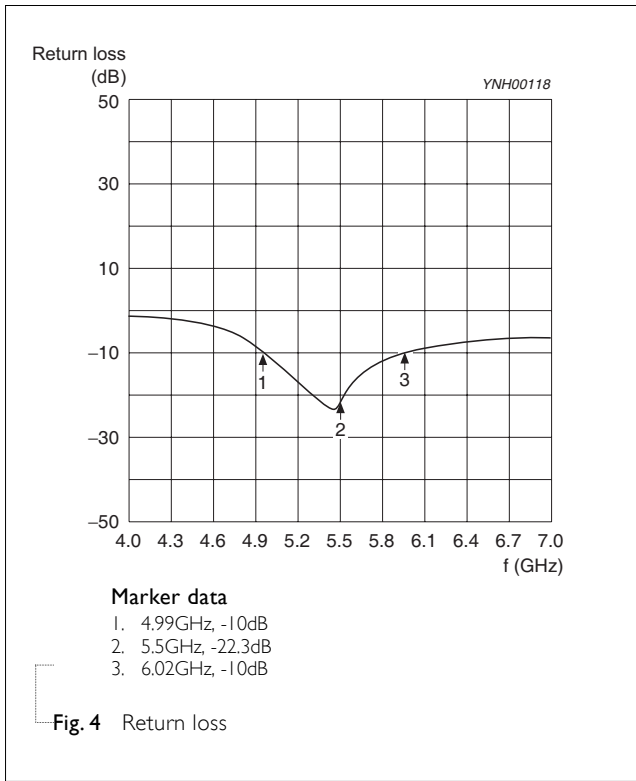

REVISION HISTORYREVISION   DATE   CHANGE NOTIFICATION   DESCRIPTION

---

Version 0	Mar. 27, 2013	-	- New datasheet for Ceramic Chip Antenna, 5 GHz application, 3216 series
-----------	---------------	---	--

---

单击下面可查看定价，库存，交付和生命周期等信息

[>>Yageo\(国巨\)](#)