

DATA SHEET

CURRENT SENSOR - LOW TCR

AUTOMOTIVE GRADE

PA series

5%, 1%, 0.5%

sizes 0201/0402/0603/0805/1206/2010

RoHS compliant & Halogen free



SCOPE

This specification describes PA0201/0402/0603/0805/1206/2010 series current sensor - low TCR with lead-free terminations metal substrate.

APPLICATIONS

- Smart Phone
- Batteries
- Computer
- Telecom / Datacom
- Industrial / Power supply
- Car electronics

FEATURES

- AEC-Q200 qualified
- Halogen-free Epoxy
- RoHS compliant
- Reduce environmentally hazardous wastes
- High component and equipment reliability
- Non-forbidden materials used in products/production
- Low resistances applied to current sensing
- Moisture sensitivity level: MSL 1

ORDERING INFORMATION - GLOBAL PART NUMBER

Global part numbers are identified by the series, size, tolerance, packing type, temperature coefficient, taping reel and resistance value.

GLOBAL PART NUMBER

PA XXXX X X X XX XXXX X
 (1) (2) (3) (4) (5) (6) (7)

(1) SIZE

0201/0402/0603/0805/1206/2010

(2) TOLERANCE

D = ±0.5% (for 5mΩ ~ 20mΩ)
 F = ±1%
 J = ±5%

(3) PACKAGING TYPE

R = Paper taping reel (PA0201~PA1206)
 K = Embossed taping reel (PA2010)

(4) TEMPERATURE COEFFICIENT OF RESISTANCE

E = ± 50ppm/°C
 M = ± 75ppm/°C
 F = ± 100ppm/°C
 L = ± 150ppm/°C
 G = ± 200ppm/°C

(5) TAPING REEL

07 / 7W / 7T / 47 / 57 / 87 inch dia. Reel and specific rated power
 Detailed power rating are shown in the Table 2.

(6) RESISTANCE VALUE

1 mΩ to 20 mΩ

(7) DEFAULT CODE

Letter L / Z is the system default code for ordering only. (Note)
 L is for 0201/0402/0603/0805
 Z is for only 1206/2010

Resistance code rule	Example
0RXXX (1 to 20 mΩ)	0R001 = 1 mΩ 0R02 = 20 mΩ

ORDERING EXAMPLE

The ordering code for a PA0805 0.125W chip resistor,TC50 value 0.01Ω (10mR) with ±1% tolerance, supplied in 7-inch tape reel with 5Kpcs quantify is: PA0805FRE070R01L.

NOTE

I. All our RChip products are RoHS compliant. "LFP" of the internal 2D reel label mentions "Lead-Free Process"

MARKING

PA0201/0402/0603/0805/1206/2010



CONSTRUCTION

The resistors are constructed using outstanding TCR level material, which makes Yageo PA resistors excellent for current sensing application in battery charger circuit & DC-DC converter.

The composition of the resistive material is adjusted to give the approximate required resistance. Finally, the three external terminations (Cu / Ni / matte Tin) are added, as shown in Fig. 2.

Outlines

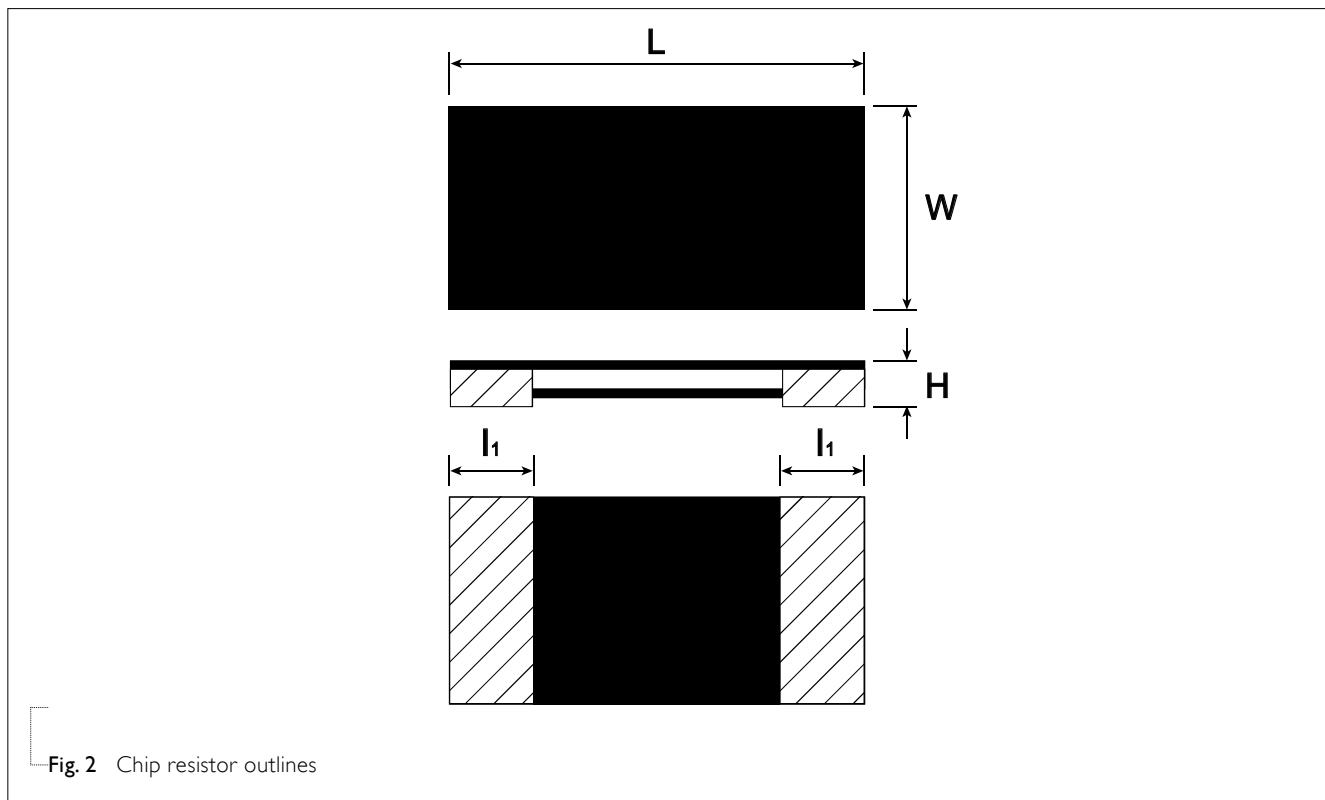

DIMENSION

Table 1 For outlines, please refer to Fig. 2

TYPE	RESISTANCE RANGE	L (mm)	W (mm)	H (mm)	ll (mm)
PA0201	5mΩ ≤ R ≤ 20mΩ	0.60±0.03	0.31±0.04	Max. 0.30	0.15±0.06
PA0402	2mΩ ≤ R ≤ 20mΩ	1.00±0.10	0.55±0.10	Max. 0.40	0.25±0.10
PA0603	1 mΩ	1.60±0.20	0.80±0.20	0.55±0.15	0.38±0.12
	2mΩ ≤ R ≤ 20mΩ	1.60±0.20	0.80±0.20	0.45±0.15	0.38±0.12
PA0805	1mΩ	2.03±0.20	1.27±0.20	0.55±0.15	0.60±0.15
	1.5/ 2mΩ	2.03±0.20	1.27±0.20	0.45±0.15	0.50±0.15
	2.5mΩ ≤ R ≤ 20mΩ	2.03±0.20	1.27±0.20	0.30±0.15	0.35±0.20
PA1206	1mΩ	3.20±0.25	1.60±0.25	0.65±0.25	0.51±0.25
	2mΩ	3.20±0.25	1.60±0.25	0.55±0.25	0.60±0.25
	2.5/ 3mΩ	3.20±0.25	1.60±0.25	0.40±0.25	0.80±0.30
	4mΩ ≤ R ≤ 20mΩ	3.20±0.25	1.60±0.25	0.40±0.25	0.60±0.30
PA2010	1mΩ ≤ R ≤ 3mΩ	5.08±0.25	2.54±0.25	0.50±0.25	1.40±0.25
	4mΩ ≤ R ≤ 20mΩ	5.08±0.25	2.54±0.25	0.40±0.25	0.70±0.25

Note:

1. For relevant physical dimensions, please refer to construction outlines.
2. Please contact with sales offices, distributors and representatives in your region before ordering.

ELECTRICAL CHARACTERISTICS

Table 2

SIZE	POWER RATING (I)						TOLERANCE	RESISTANCE RANGE	TEMPERATURE COEFFICIENT OF RESISTANCE	
	07	7W	7T	47	57	87				
0201	1/20W	1/10W	3/20W	1/4W	--	--	±1% ±5%	5mΩ ≤ R ≤ 20mΩ	±150 ppm/°C	
0402	1/16W	1/8W	1/6W	1/4W	1/3W	--		2mΩ ≤ R ≤ 20mΩ	±150 ppm/°C	
0603	1/10W	1/5W	1/3W	2/5W	1/2W	--	±0.5% ±1% ±5%	1mΩ ≤ R ≤ 20mΩ	1mΩ 2/ 2.5mΩ 3mΩ ≤ R ≤ 10mΩ	±200 ppm/°C ±150 ppm/°C ±50 ppm/°C, ±75 ppm/°C
0805	1/8W	1/4W	--	1/2W	--	1W		10mΩ	1/ 1.5mΩ 2mΩ ≤ R ≤ 20mΩ	±150 ppm/°C ±50 ppm/°C
1206	1/4W	1/2W	--	1W	--	--	±0.5% ±1% ±5%	5mΩ ≤ R ≤ 20mΩ 1mΩ ≤ R ≤ 20mΩ	1/ 2mΩ 3mΩ ≤ R ≤ 20mΩ	±100 ppm/°C ±50 ppm/°C
2010	0.5W	1W	1.5W	-	-	-	±1% ±5%	1mΩ ≤ R ≤ 20mΩ	±50 ppm/°C	
	0.5W	1W	1.5W	2W	-	-		1mΩ ≤ R ≤ 10mΩ		

Note: Please contact with sales offices, distributors and representatives in your region before ordering.

FUNCTIONAL DESCRIPTION

OPERATING TEMPERATURE RANGE

PA0201/ 0402 Range: -55°C to +125°C

PA0603/ 0805 Range: -55°C to +155°C

PA1206/ 2010 Range: -55°C to +170°C

POWER RATING

Standard rated power at 70°C: For detail power value, please refer to Table 2.

RATED VOLTAGE

The DC or AC (rms) continuous working voltage corresponding to the rated power is determined by the following formula:

$$V = \sqrt{P \times R}$$

Where

V = Continuous rated DC or AC (rms) working voltage (V)

P = Rated power (W)

R = Resistance value (Ω)

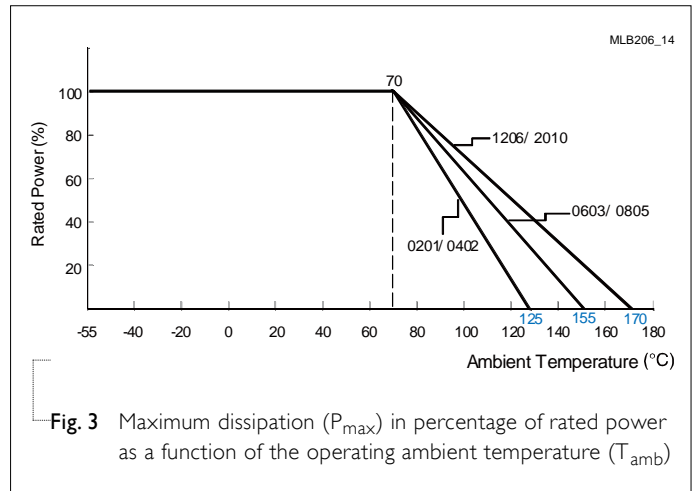

PACKING STYLE AND PACKAGING QUANTITY

Table 3 Packing style and packaging quantity

PACKING STYLE	REEL DIMENSION	PA0201	PA0402	PA0603	PA0805	PA1206	PA2010
Paper Taping Reel (R)	7" (178 mm)	10,000	10,000	5,000	5,000	4,000	-
Embossed Taping Reel (K)	7" (178 mm)	-	-	-	-	-	4,000

PAPER TAPE

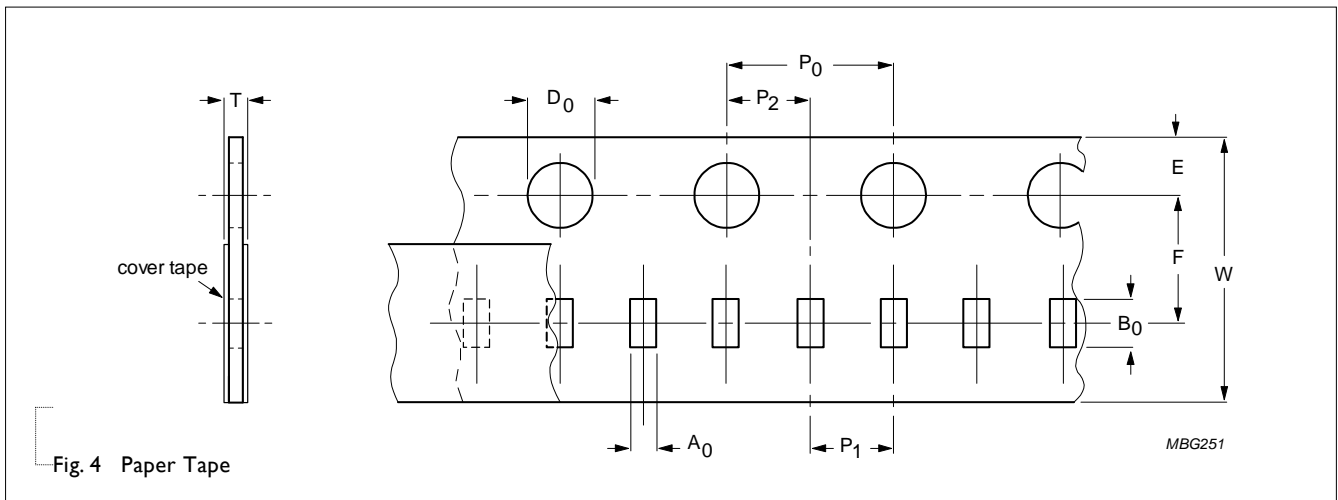

EMBOSSED TAPE

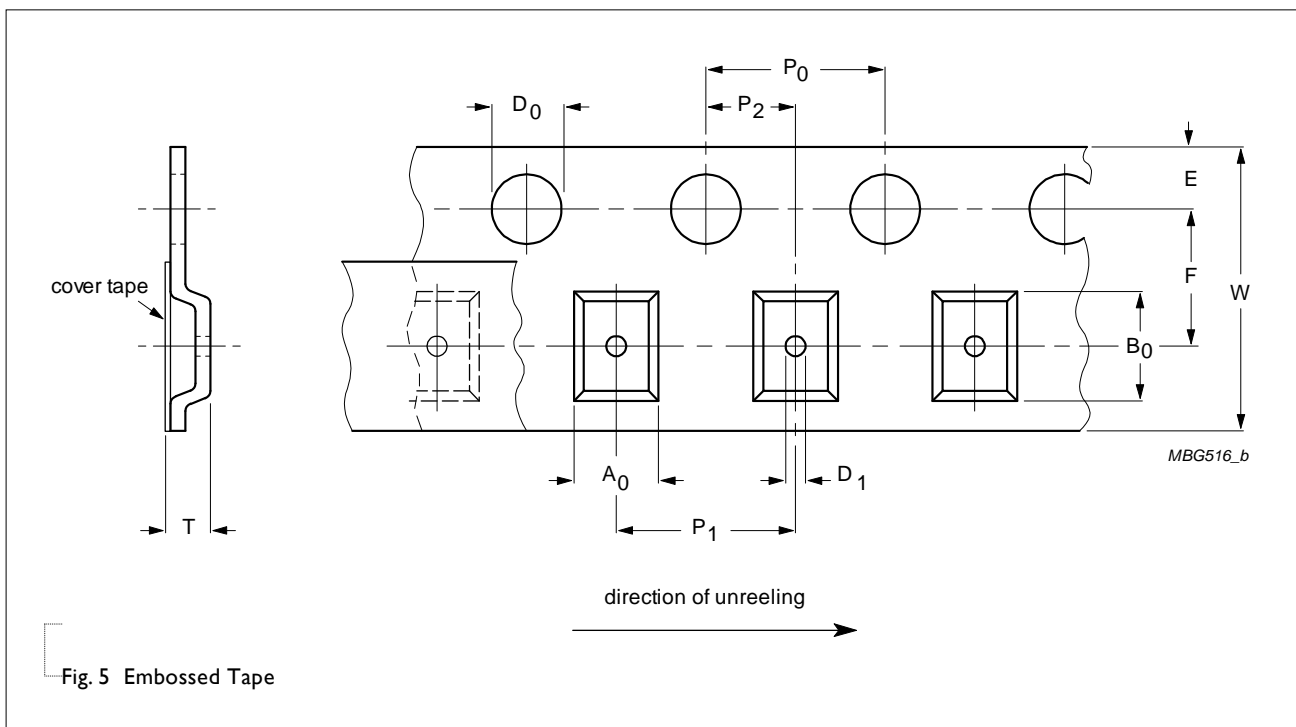

Fig. 5 Embossed Tape

Table 4 Dimensions of paper tape for relevant chip resistors size

SIZE	SYMBOL										Unit: mm
	A ₀	B ₀	W	E	F	P ₀	P ₁	P ₂	ΦD ₀	T	
PA0201	0.39±0.10	0.70±0.10	8.0±0.30	1.75±0.10	3.50±0.10	4.00±0.10	2.00±0.10	2.00±0.10	1.55±0.05	0.43±0.10	
PA0402	0.59±0.10	1.10±0.10	8.0±0.30	1.75±0.10	3.50±0.10	4.00±0.10	2.00±0.10	2.00±0.10	1.55±0.05	0.53±0.10	
PA0603	1.08±0.10	1.90±0.10	8.0±0.30	1.75±0.10	3.50±0.10	4.00±0.10	4.00±0.10	2.00±0.10	1.55±0.05	0.60±0.10	
PA0805	1.60±0.10	2.35±0.10	8.0±0.30	1.75±0.10	3.50±0.10	4.00±0.10	4.00±0.10	2.00±0.10	1.55±0.05	0.60±0.10*	
	1.60±0.10	2.35±0.10	8.0±0.30	1.75±0.10	3.50±0.10	4.00±0.10	4.00±0.10	2.00±0.10	1.55±0.05	0.53±0.10**	
PA1206	1.90±0.10	3.50±0.10	8.0±0.30	1.75±0.10	3.50±0.10	4.00±0.10	4.00±0.10	2.00±0.10	1.55±0.05	0.85±0.15	

Note:

* 1~2mΩ

** 2.5~20mΩ

Table 5 Dimensions of embossed tape for relevant chip resistors size

SIZE	SYMBOL										Unit: mm
	A ₀	B ₀	W	E	F	P ₀	P ₁	P ₂	ΦD ₀	T	
PA2010	3.40±0.15	6.70±0.15	12.0±0.30	1.75±0.10	5.50±0.10	4.00±0.10	4.00±0.10	2.00±0.10	1.55±0.10	0.85±0.15	

REEL SPECIFICATION

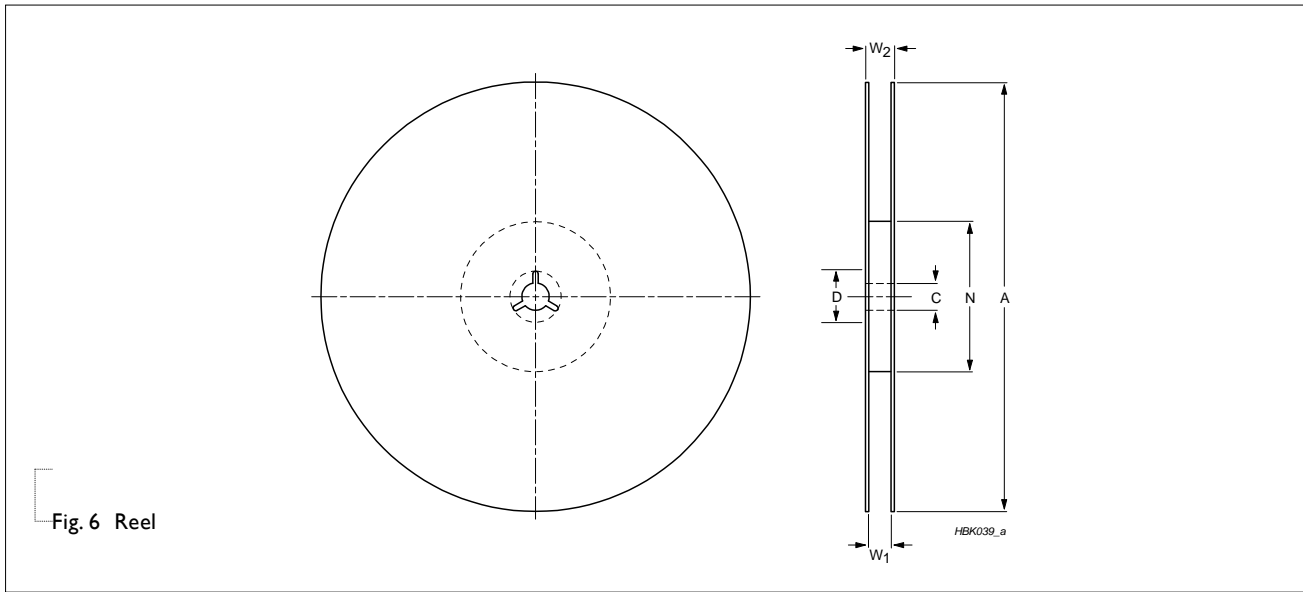
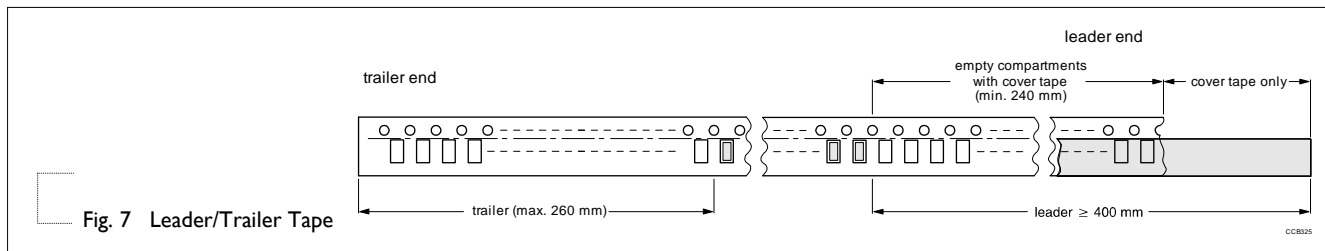

Fig. 6 Reel

Table 6 Dimensions of reel specification for relevant chip resistors size

SIZE	QUANTITY PER REEL	REEL SIZE		SYMBOL				
		8mm TAPE WIDE	12mm TAPE WIDE	A	N	C	D	W_1
PA0201	10,000	7" (Φ 178mm)	-	178.0 \pm 1.0	60.0+1/-0	13.50 \pm 0.5	21.0 \pm 0.8	9.0 \pm 0.5
PA0402	10,000	7" (Φ 178mm)	-	178.0 \pm 1.0	60.0+1/-0	13.50 \pm 0.5	21.0 \pm 0.8	9.0 \pm 0.5
PA0603	5,000	7" (Φ 178mm)	-	178.0 \pm 1.0	60.0+1/-0	13.50 \pm 0.5	21.0 \pm 0.8	9.0 \pm 0.5
PA0805	5,000	7" (Φ 178mm)	-	178.0 \pm 1.0	60.0+1/-0	13.50 \pm 0.5	21.0 \pm 0.8	9.0 \pm 0.5
PA1206	4,000	7" (Φ 178mm)	-	178.0 \pm 1.0	60.0+1/-0	13.50 \pm 0.5	21.0 \pm 0.8	9.0 \pm 0.5
PA2010	4,000	-	7" (Φ 178mm)	178.0 \pm 1.0	60.0+1/-0	13.50 \pm 0.5	21.0 \pm 0.8	13.6 \pm 0.5

LEADER/TRAILER TAPE SPECIFICATION



FOOTPRINT AND SOLDERING PROFILES

For recommended soldering profiles, please refer to data sheet “Chip resistors mounting”.

FOOTPRINT

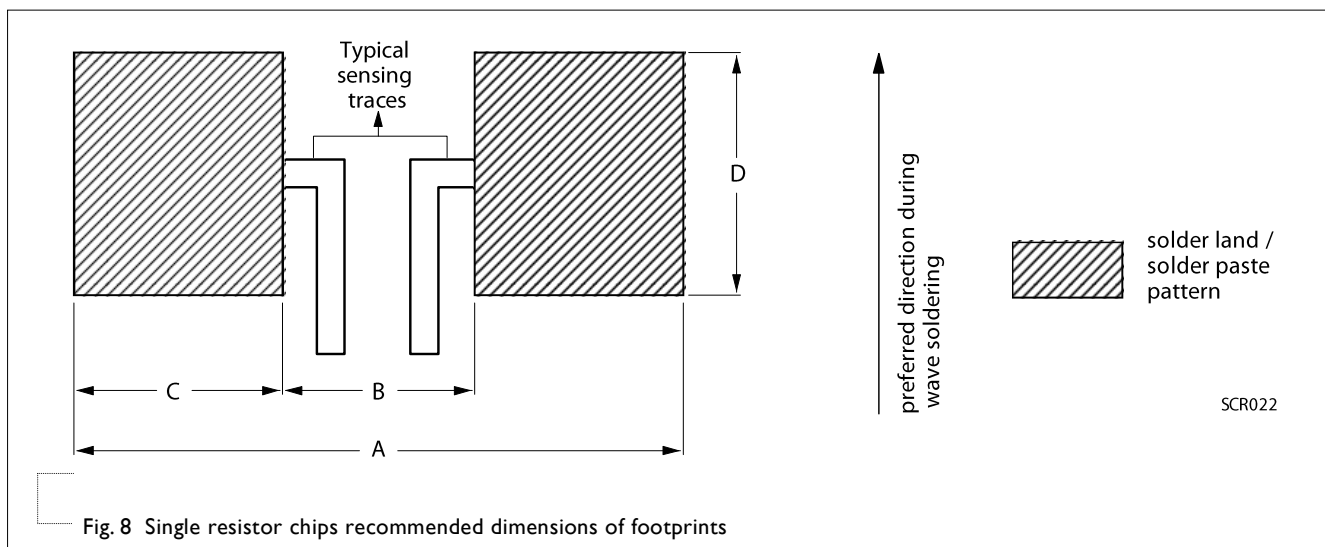

Table 7 Footprint dimensions

						Unit: mm
TYPE	RESISTANCE RANGE	A	B	C	D	
PA0201	$5m\Omega \leq R \leq 20m\Omega$	1.00	0.30	0.35	0.40	
PA0402	$2m\Omega \leq R \leq 20m\Omega$	2.00	0.40	0.80	0.60	
PA0603	$1m\Omega$	2.20	0.50	0.70	0.90	
	$1m\Omega < R \leq 20m\Omega$	2.20	0.80	0.70	0.90	
PA0805	$1m\Omega$	4.10	0.50	1.80	2.18	
	$1.5m\Omega \leq R \leq 20m\Omega$	4.60	1.00	1.80	2.18	
PA1206	$1m\Omega / 2m\Omega$	4.20	1.00	1.60	1.84	
	$2.5m\Omega / 3m\Omega$	4.80	1.00	1.90	1.84	
	$4m\Omega \leq R \leq 20m\Omega$	4.80	1.20	1.80	1.84	
PA2010	$1m\Omega \leq R \leq 3m\Omega$	6.00	1.40	2.30	3.00	
	$4m\Omega \leq R \leq 20m\Omega$	6.00	3.50	1.25	3.00	

TESTS AND REQUIREMENTS

Table 8 Test condition, procedure and requirements

TEST	TEST METHOD	PROCEDURE	REQUIREMENT
Short time overload	IEC60115-1 4.13	5 times of rated power for 5 seconds at room temperature	$\pm(1.0\%+0.0005\Omega)$ No visible damage
High Temperature Exposure/ Endurance at Upper Category Temperature	MIL-STD-202G-Method 108A	1,000 hours at maximum operating temperature depending on specification, unpowered No direct impingement of forced air to the parts Tolerances: 0201/0402: $125\pm 3^{\circ}\text{C}$ 0603/0805: $155\pm 3^{\circ}\text{C}$ 1206/2010: $170\pm 3^{\circ}\text{C}$	$\pm(1.0\%+0.0005\Omega)$
Temperature Cycling	JESD22-A104C	1,000 cycles, $-55/+125^{\circ}\text{C}$ for 1 cycle per hour	$\pm(1.0\%+0.0005\Omega)$
Moisture Resistance	MIL-STD-202G-Method 106F	Each temperature / humidity cycle is defined at 8 hours (method 106F), 3 cycles / 24 hours for 10d with $25^{\circ}\text{C} / 65^{\circ}\text{C}$ 95% R.H, without steps 7a & 7b, unpowered	$\pm(0.5\%+0.0005\Omega)$
Biased Humidity	MIL-STD-202 Method 103	1,000 hours; $85^{\circ}\text{C} / 85\%$ RH 10% of operating power	$\pm(1.0\%+0.0005\Omega)$
Operational Life/ Endurance	MIL-STD-202G-Method 108A IEC 60115-1 4.25.1	1,000 hours at $125\pm 3^{\circ}\text{C}$, de-rated power applied for 1.5 hours on, 0.5 hour off, still-air required	$\pm(1.0\%+0.0005\Omega)$
		1,000 hours at $70\pm 2^{\circ}\text{C}$ applied rated power 1.5 hours on, 0.5 hour off, still air required	$\pm(1.0\%+0.0005\Omega)$
Resistance to Solvents	MIL-STD-202 Method 215	Immerse in isopropyl alcohol for 5 min with ultrasonic at room temperature	No visible damage
Mechanical Shock	MIL-STD-202 Method 213	Three shocks in each direction shall be applied along the three mutually perpendicular axes of the test specimen. Peak value: 100 g's Duration: 6 ms Velocity change: 12.3 ft/s Waveform: Half sine	$\pm(0.5\%+0.0005\Omega)$
Vibration	MIL-STD-202 Method 204	5 g's for 20 min., 12 cycles each of 3 orientations Test from 10-2000 Hz.	$\pm(0.5\%+0.0005\Omega)$
Resistance to Soldering Heat	MIL-STD-202G-method 210F	Condition B, no pre-heat of samples Leadfree solder, 260°C , 10 seconds immersion time Procedure 2 for SMD: devices fluxed and cleaned with isopropanol	$\pm(0.5\%+0.0005\Omega)$ No visible damage

TEST	TEST METHOD	PROCEDURE	REQUIREMENT
Thermal Shock	MIL-STD-202 Method 107	-55/+125°C, Number of cycles is 300. Maximum transfer time is 20 seconds. Dwell time is 15 minutes. Air -Air	±(1.0%+0.0005Ω) No visible damage
Electrostatic Discharge	AEC-Q200-002	Human Body Model, 1 pos + 1 neg. 0805/ 1206/ 2010 : 2KV 0402/ 0603 : 1KV 0201: 500V	±(1.0%+0.0005Ω) No visible damage
Solderability - Wetting	J-STD-002	(a) Method B, aging 4 hours at 155°C dry heat, dipping at 235±3°C for 5±0.5 seconds. (b) Method B, steam aging 8 hours, dipping at 215±3°C for 5±0.5 seconds. (c) Method D, steam aging 8 hours, dipping at 260±3 °C for 30±0.5 seconds.	Well tinned (>95% covered) No visible damage
Flammability	UL94	Try to inflame a specimen by a needle flame	No ignition of specimen;V-0
Board Flex / Bending	AEC-Q200-005	Chips mounted on a 90mm glass epoxy resin PCB (FR4), Bending for 0201: 3mm 0402 and above: 2mm Holding time: Min.60 seconds	±(1.0%+0.0005Ω)
Terminal Strength (SMD)	AEC-Q200-006	Applied 0201: 3N 0402: 5N 0603/ 0805/ 1206/ 2010: 17.7N for 60±1 seconds.	±(1.0%+0.0005Ω) No visible damage
Flame Retardance	AEC-Q200-001	Apply voltage from 9V to 32V to increase the surface temp to 350°C	No flame, no explosion
Temperature Coefficient of Resistance (T.C.R.)	IEC 60115-1 4.8	At +25/+125°C Formula: $T.C.R = \frac{R2 - R1}{R1(t2 - t1)} \times 10^6 \text{ (ppm/°C)}$ Where t1 = +25°C or specified room temperature t2 = +125°C test temperature R1 = resistance at reference temperature in ohms R2 = resistance at test temperature in ohms	Refer to table 2

REVISION HISTORY

REVISION	DATE	CHANGE NOTIFICATION	DESCRIPTION
Version 0	May 07, 2020	-	- New datasheet for automotive grade current sensor – PA0201/0402/0603/0805/1206/2010 series.

“Yageo reserves all the rights for revising the content of this datasheet without further notification, as long as the products itself are unchanged. Any product change will be announced by PCN.”

单击下面可查看定价，库存，交付和生命周期等信息

[>>Yageo\(国巨\)](#)