

3-Terminal 1.5A Positive Adjustable Regulator

The LM317D are monolithic integrated circuit in TO-252 package sintended for use as positive adjustable voltage regulators.They are designed to supply more than 1.5A of load current with an output voltage adjustable over a 1.2 to 37V range.

The nominal output voltage is selected by means of only a resistive divider, making the device exceptionally easy to use and eliminatingthestocking of many fixed regulators

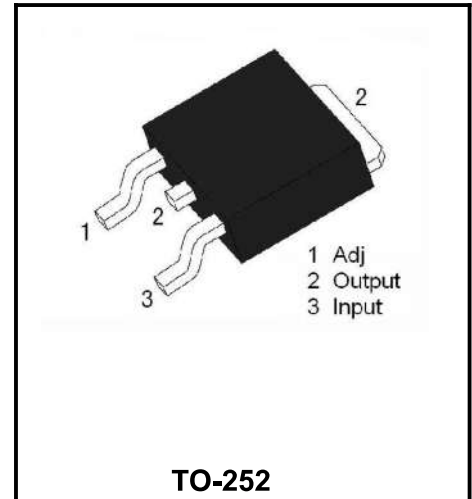

Features

- Output Voltage Range : 1.2V to 37V
- Output Current in excess of 1.5A
- Internal Thermal Overload Protection
- Internal Short Circuit Current Limiting
- Output Transistor Safe Operating Area Compensation

Internal Block Diagram

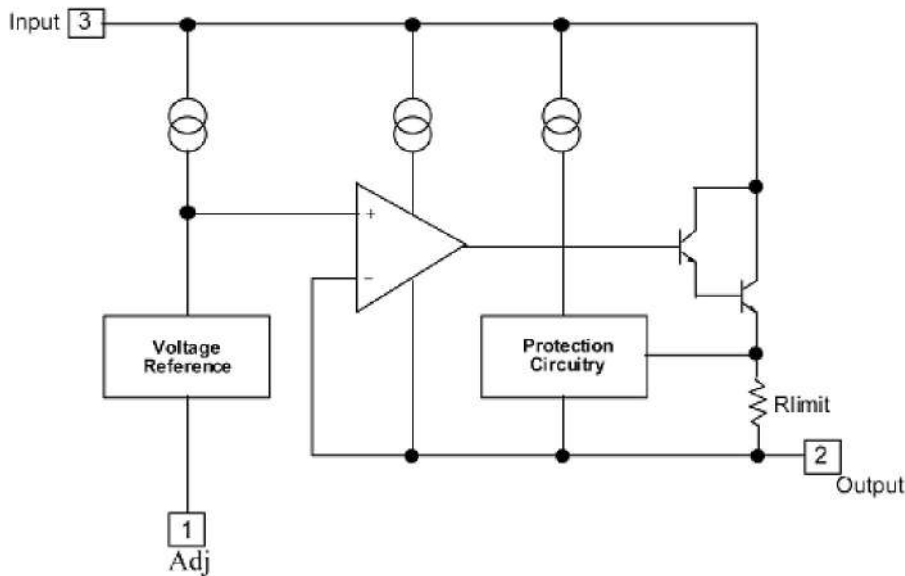

Absolute Maximum Ratings

Parameter	Symbol	Value	Unit
Input-output Differential Voltage	$V_i - V_o$	40	V
Power Dissipation	P_D	Intenrally Limited	W
Operating Junction Temperature	T_j	0 ~ +125	°C
Storage Temperature	T_{stg}	-60 ~ +150	°C
Temperature Coefficient of Output Voltage	$\Delta V_o / \Delta T$	±0.02	% / °C

Note 1: Absolute Maximum Ratings: are those values beyond which the safety of the device cannot be guaranteed. The device should not be operated at these limits. The parametric values defined in the Electrical Characteristics tables are not guaranteed at the absolute maximum ratings. The "Recommended Operating Conditions" table will define the conditions for actual device operation.

Electrical Characteristics
(Vi - Vo = 5 V, Io = 0.5A, TA = 25°C, unless otherwise specified)

Parameter	Symbol	Conditions	Value			Unit
			Min	Typ	Max	
Line Regulation (Note2)	$\Delta V_{OUT}/V_{OUT}$	$3V \leq V_I - V_O \leq 40V, T_A = 25^\circ C$		0.01	0.04	%V
		$3V \leq V_I - V_O \leq 40V$		0.002	0.07	
Load Regulation(Note2)	ΔV_{OUT}	$10mA \leq I_O \leq 1.5A$	$V_O < 5V$	18	25	mV%/V _O
			$V_O \geq 5V$	0.4	0.5	
		$10mA \leq I_O \leq 1.5A$	$V_O < 5V$	40	70	mV%/V _O
			$V_O \geq 5V$	0.8	1.5	
Adjustment Pin Current	I_{ADJ}	$T_j = 25^\circ C$		50	100	μA
Adjustment Pin Current	ΔI_{ADJ}	$3V \leq V_I - V_O \leq 40V$ $10mA \leq I_O \leq 1.5A, P_D \leq 20W$		2.0	5.0	μA
Reference Voltage	V_{REF}	$3V \leq V_I - V_O \leq 40V$ $10mA \leq I_O \leq 1.5A, P_D \leq 20W$	1.20	1.25	1.30	V
Minimum Load Current	$I_{L(Min)}$	$V_i - V_o = 40V$		3.5	10	mA
Maximum Output Current	$I_{O(Max)}$	$V_I - V_O = 40, P_D \leq 20W$	0.2	0.3		A
Maximum Load Current	eN	$10Hz \leq f \leq 10kHz$		0.003	0.01	% / V _O
RMS Noise,% of V _{OUT}	RR	$V_O = 10V, f = 120Hz$ (Note3)	C_{ADJ}		65	dB
			$C_{ADJ} = 10\mu F$	66	80	

Note 2: Load and line regulation are specified at constant junction temperature. Change in V_O due to heating effects must be taken into account separately. Pulse testing with low duty is used. (P_{MAX} = 20S)

Note 3: C_{ADJ}, when used, is connected between the adjustment pin and ground.

Thermal resistances

Parameter	Symbol	Conditions	Value	Unit
Junction to ambient	R θ_{JA}		112	$^\circ C/W$
Junction to case	R θ_{JC}		12	$^\circ C/W$

Typical Application

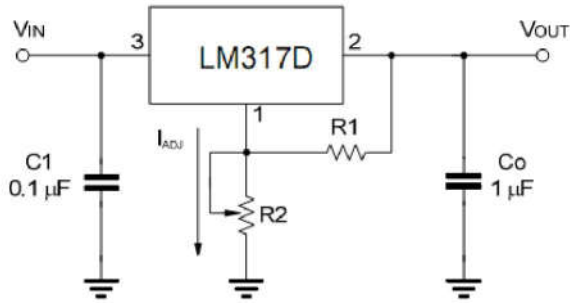

Fig.1 Programmable voltage regulator

$$V_{OUT} = 1.25 \cdot (1 + R2/R1) + I_{Adj} \cdot R2$$

Ci is required when regulator is located an appreciable distance from power supply filter. Co is not needed for stability, however, it does improve transient response.

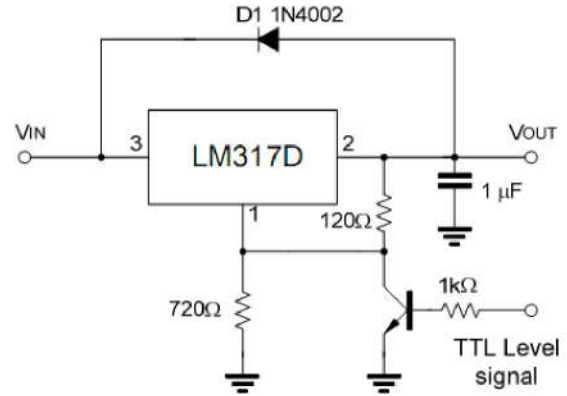

Fig.2 Regulator with On-off control

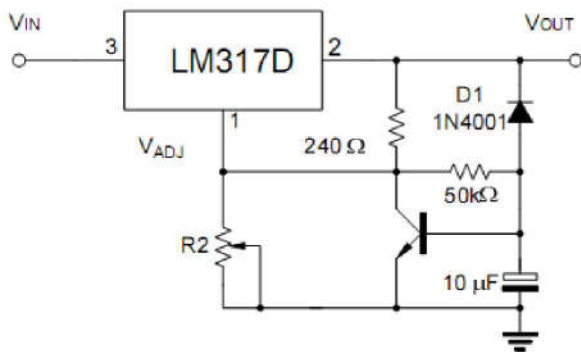
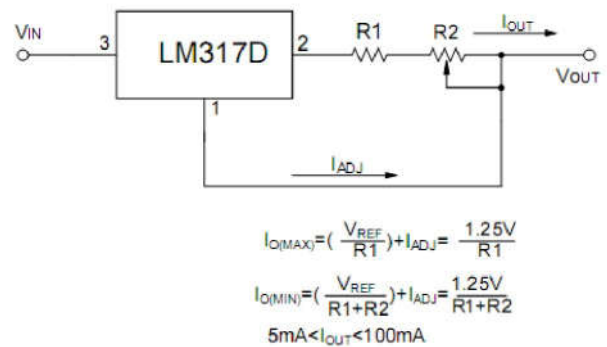

Fig.3 Soft Start Application



$$I_{O(MAX)} = \left(\frac{V_{REF}}{R1} \right) + I_{ADJ} = \frac{1.25V}{R1}$$

$$I_{O(MIN)} = \left(\frac{V_{REF}}{R1+R2} \right) + I_{ADJ} = \frac{1.25V}{R1+R2}$$

$$5mA < I_{OUT} < 100mA$$

Fig.4 Constant Current Application

Typical Characteristics

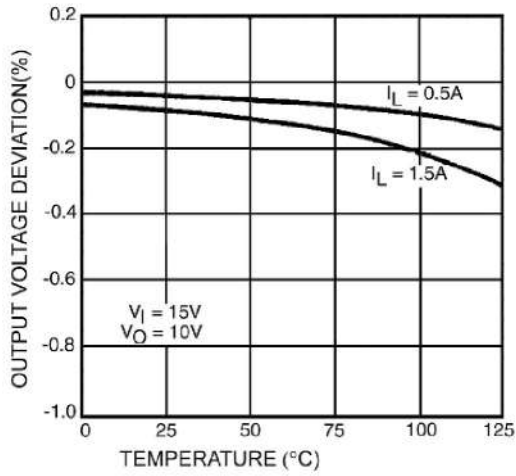

Fig.5 Load Regulation vs. temperature

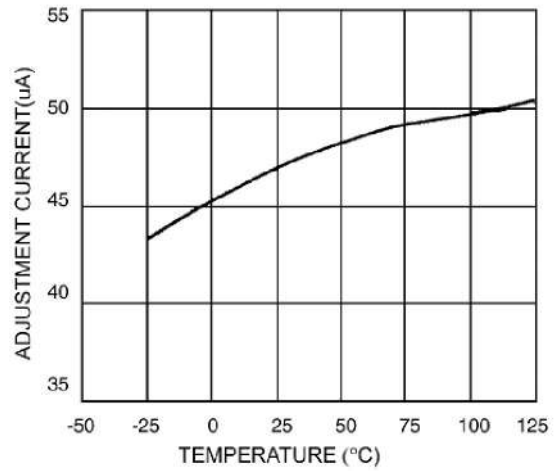

Fig.6 Adjustment Current vs. Temperature

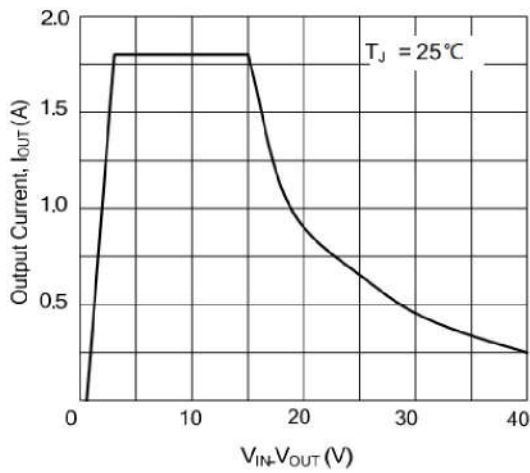

Fig.7 Current limit

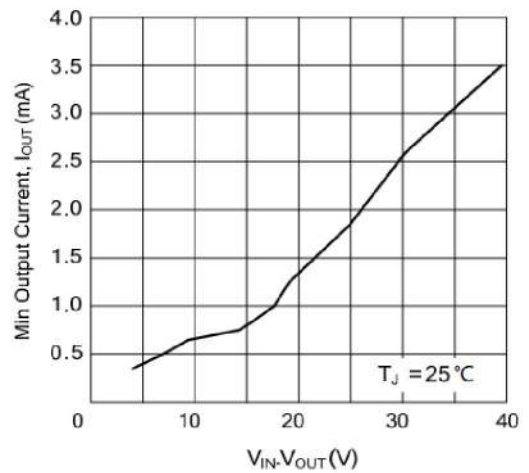
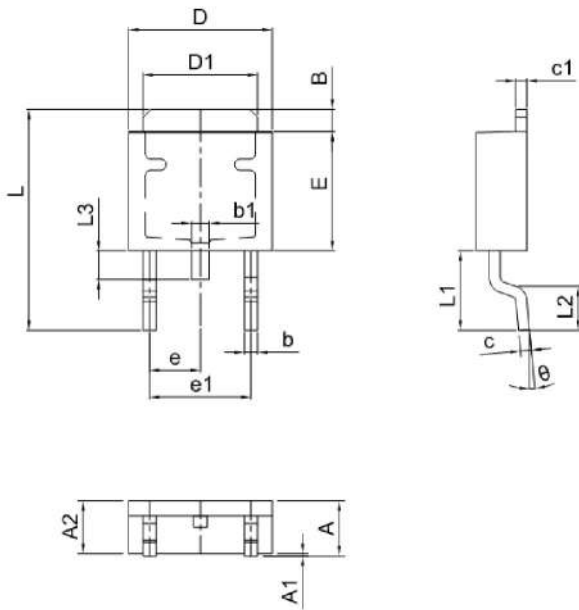

Fig.8 Minimum Operating Current

Package Dimensions

Symbol	Millimeter		Inches	
	Min.	Max.	Min.	Max.
A	2.20	2.50	0.087	0.098
A1	0.00	0.12	0.000	0.005
A2	2.20	2.40	0.087	0.094
B	1.20	1.60	0.047	0.063
b	0.50	0.70	0.020	0.028
b1	0.70	0.90	0.028	0.035
c	0.40	0.60	0.016	0.024
c1	0.40	0.60	0.016	0.024
D	6.35	6.65	0.250	0.262
D1	5.20	5.40	0.205	0.213
E	5.40	5.70	0.213	0.224
e	2.20	2.40	0.087	0.094
e1	4.40	4.80	0.173	0.189
L	9.60	10.20	0.378	0.402
L1	2.70	3.10	0.106	0.122
L2	1.40	1.80	0.055	0.071
L3	0.90	1.50	0.035	0.059



Product Specification Classification

Part Number	Package	Marking	Pack
LM317D	TO-252	YFW LM317D XXXXX	2500PCS/Tape

单击下面可查看定价，库存，交付和生命周期等信息

[>>YFW\(佑风微\)](#)