

## Surface Mount Schottky Barrier Rectifier

Reverse Voltage - 40 to 200 V

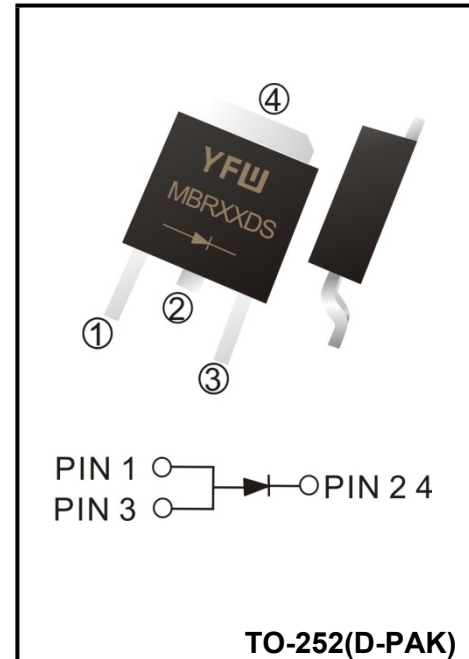
Forward Current - 5 A

### FEATURES

- ◆ High current capability
- ◆ Low forward voltage drop
- ◆ High surge capability
- ◆ High temperature soldering guaranteed
- ◆ Mounting position: any
- ◆ Lead free in comply with EU RoHS 2011/65/EU directives

### MECHANICAL DATA

- ◆ Case: TO-252(D-PAK)
- ◆ Terminals: Solderable per MIL-STD-750, Method 2026
- ◆ Approx. Weight: 0.32g / 0.011oz



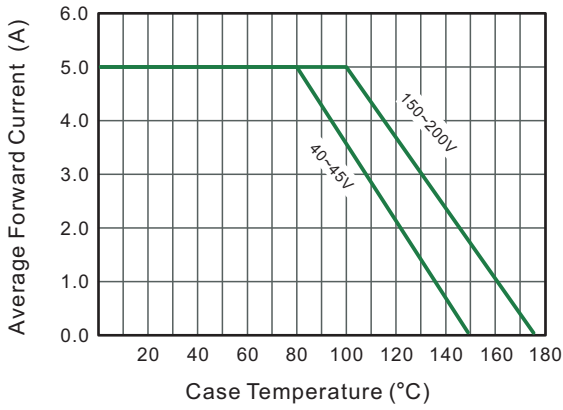
Maximum Ratings and Electrical characteristics  
Ratings at 25 ° ambient temperature unless otherwise specified.

Parameter	Symbols	MBR540DS	MBR545DS	MBR560DS	MBR5100DS	MBR5150DS	MBR5200DS	Units	
Maximum Repetitive Peak Reverse Voltage	$V_{RRM}$	40	45	60	100	150	200	V	
Maximum RMS voltage	$V_{RMS}$	28	31.5	42	70	105	140	V	
Maximum DC Blocking Voltage	$V_{DC}$	40	45	60	100	150	200	V	
Maximum Average Forward Rectified Current	$I_{F(AV)}$	5.0						A	
Peak Forward Surge Current, 8.3ms Single Half Sine-wave Superimposed On Rated Load (JEDEC method)	$I_{FSM}$	120						A	
Maximum Instantaneous Forward Voltage at 5 A	$V_F$	0.65		0.70	0.85	0.90	0.92	v	
Maximum Instantaneous Reverse Current at Rated DC Reverse Voltage $T_A = 25^{\circ}C$ $T_A = 100^{\circ}C$	$I_R$	0.1 20			0.05 20			mA	
Typical Junction Capacitance <sup>(1)</sup>	$C_j$	600	400					pF	
Typical Thermal Resistance <sup>(2)</sup>	$R_{\theta JA}$	35						°C/W	
Operating Junction Temperature Range	$T_j$	-55 ~ +150				-55 ~ +175			°C
Storage Temperature Range	$T_{stg}$	-55 ~ +150				-55 ~ +175			°C

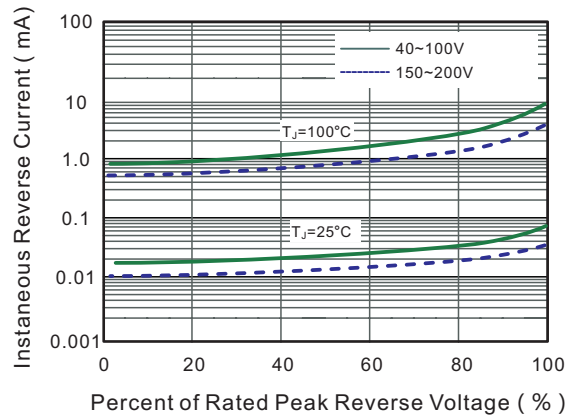
(1) Measured at 1 MHz and applied reverse voltage of 4 V D.C

(2) P.C.B. mounted with 10cm X 10cmX1mm copper pad areas.

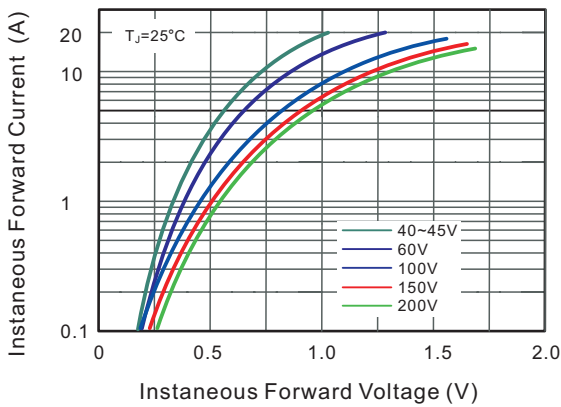
**Fig.1 TYPICAL FORWARD CURRENT DERATING CURVE**



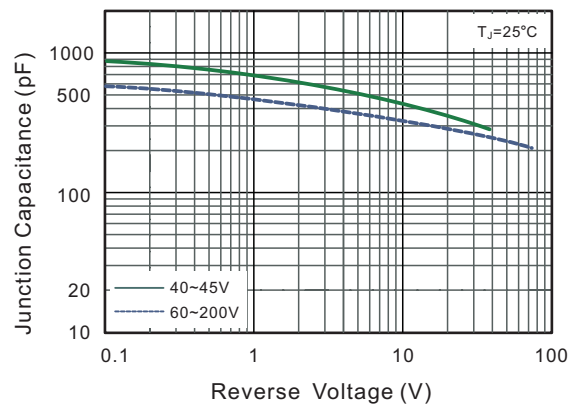
**Fig.2 Typical Reverse Characteristics**



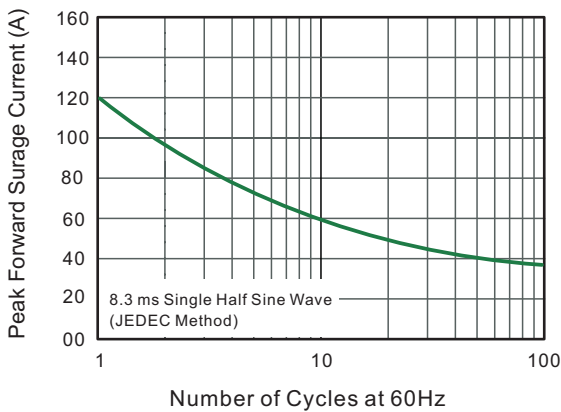
**Fig.3 Typical Forward Characteristic**



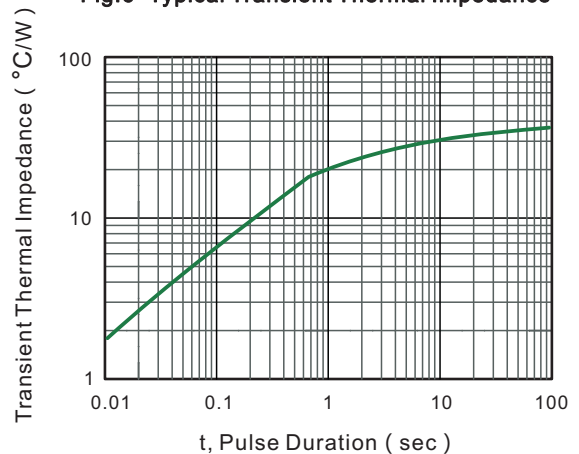
**Fig.4 Typical Junction Capacitance**



**Fig.5 Maximum Non-Repetitive Peak Forward Surge Current**

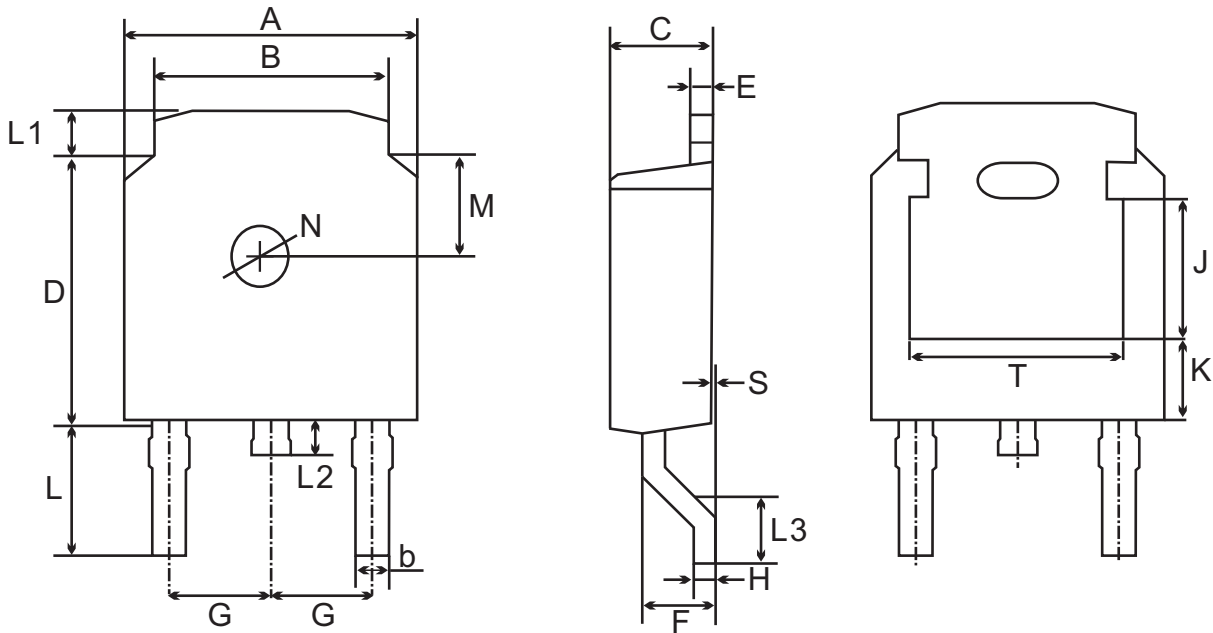


**Fig.6- Typical Transient Thermal Impedance**



Package Outline

TO-252(D-PAK)



UNIT		A	B	b	C	D	E	F	G	H	L	L1	L2	L3	S	M	N	J	K	T
mm	max	6.7	5.5	0.8	2.5	6.3	0.6	1.8	2.29 TYPICAL	0.55	3.1	1.2	1.0	1.75	0.1	1.8 TYPICAL	1.3 TYPICAL	3.16	1.80	4.83
	min	6.3	5.1	0.3	2.1	5.9	0.4	1.3		0.45	2.7	0.8	0.6	1.40	0.0			ref.	ref.	ref.
mil	max	264	217	31	98	248	24	71	90 TYPICAL	22	122	47	39	69	4	71 TYPICAL	51 TYPICAL	124	71	190
	min	248	201	12	83	232	16	51		18	106	31	24	55	0			ref.	ref.	ref.

Summary of Packing Options

Package	Packing Description	Packing Quantity	Industry Standard
TO-252(D-PAK)	Tape/Reel, 13" reel	2500	EIA-481-1

单击下面可查看定价，库存，交付和生命周期等信息

[>>YFW\(佑风微\)](#)