

0.8A 4QPlastic-Encapsulate Triacs

Product Summary

Symbol	Value	Unit
$I_{T(RMS)}$	0.8	A
$V_{DRM} V_{RRM}$	400/600	V
V_{TM}	1.9	V

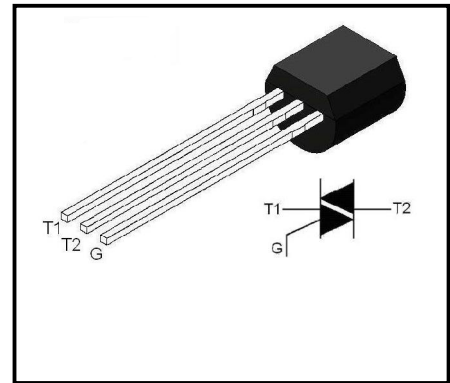

General Description

Logic level sensitive gate triac intended to be interfaced directly to microcontrollers, logic integrated circuits and other low power gate trigger circuits.

Features

- ◆ Blocking voltage to 600V (MAC97A8)
- ◆ RMS on-state current to 0.8A
- ◆ Sensitive gate in all four quadrants

Order Information

Part Number	Package	Marking	Packing	Packing Quantity
MAC97A6	TO-92	MAC97A6 XXXX	box	1000PCS/box
MAC97A8	TO-92	MAC97A8 XXXX	box	1000PCS/box

Absolute maximum ratings (Ta=25°C unless otherwise noted)

Parameter		Symbol	Value	Unit
Repetitive peak off-state voltages	MAC97A6	V_{DRM}, V_{RRM}	400	V
	MAC97A8		600	
On-State RMS Current		$I_{T(RMS)}$	0.8	A
Non-repetitive peak on-state current	t=20ms	I_{TSM}	8.0	A
	t=16.7ms		8.8	
I^2t for fusing (t=10ms)		I^2t	0.26	A ² s
Peak gate current [t=2μs (max)]	I_{GM}		1.0	A
Peak Gate Voltage [t=2μs (max)]	V_{GM}		5.0	V
Peak gate power	P_{GM}		5.0	W
Average Gate Power [Tcase=80°C, t=2us (max)]	$P_{G(AV)}$		0.1	W
Operating junction temperature	T_j		-40~110	°C
Storage Temperature	T_{stg}		-40~150	°C

Note: Absolute maximum ratings are those values beyond which the device could be permanently damaged. Absolute maximum ratings are stress ratings only and functional device operation is not implied.

Thermal Characteristics

Parameter	Symbol	Max	Unit
Thermal Resistance, Junction-to-Case	$R_{\theta JC}$	75	$^{\circ}C/W$
Thermal Resistance, Junction-to-Ambient	$R_{\theta JA}$	200	$^{\circ}C/W$
Maximum Lead Temperature for Soldering Purposes for 10 Seconds	T_L	260	$^{\circ}C$

Electrical Characteristics (TC=25 $^{\circ}C$, unless otherwise noted)

Parameter	Symbol	Test Conditions	Min	Typ	Max	Unit
Peak Repetitive Blocking Current	I_{DRM}, I_{RRM}	$V_D = \text{Rated } V_{DRM}, V_{RRM}$ Gate open			10 100	μA
Gate trigger current	I_{GT}	$V_D = 7V, R_L = 100\Omega$	T2+ G+	-	5	mA
			T2+ G-	-	5	
			T2- G-	-	5	
			T2- G+	-	7	
Gate trigger voltage	V_{GT}	$V_D = 7V, R_L = 100\Omega$	T2+ G+	-	2	mA
			T2+ G-	-	2	
			T2- G-	-	2	
			T2- G+	-	2.5	
Holding current	I_H	$V_D = 12V$, Gate Open Initiating Current = 200 mA,	-		10	mA
On-state voltage*	V_{TM}	$I_T = 1.85A$	-		1.9	V
Turn-On Time	t_{gt}	$V_D = \text{Rated } V_{DRM}$, $I_{TM} = 1.0A, I_G = 25mA$		2.0		μs

* Pulse Test: Pulse Width ≤ 1.0 ms, Duty Cycle $\leq 1\%$.

Dynamic Characteristics

Parameter	Symbol	Test Conditions	Min	Typ	Max	Unit
Critical Rate-of-Rise of Commutation Voltage	$dV/dt(c)$	$V_D = \text{Rated } V_{DRM}, I_{TM} = 0.84A$, Commutating $di/dt = 0.3 A/ms$, Gate Unenergized, $T_C = 50^{\circ}C$		5.0		$V/\mu s$
Critical Rate of Rise of Off-State Voltage	dV/dt	$V_D = \text{Rated } V_{DRM}, T_C = 110^{\circ}C$ Gate Open, Exponential Waveform		25		$V/\mu s$

Typical Characteristics

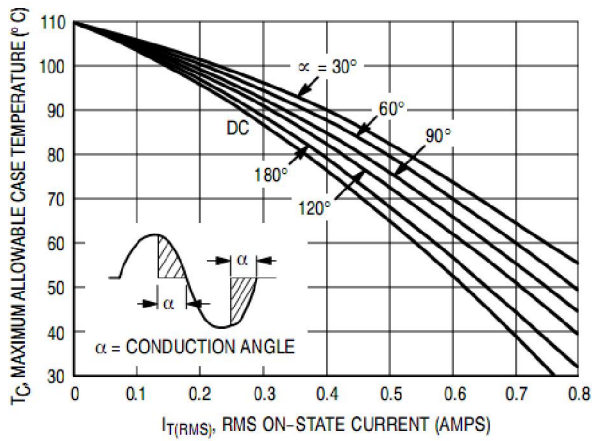

Figure 1. RMS Current Derating

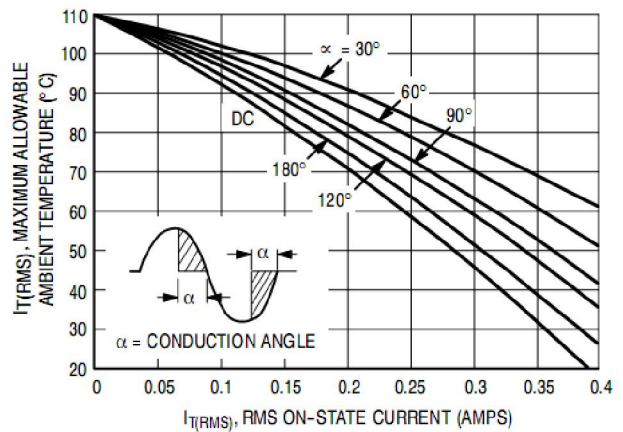

Figure 2. RMS Current Derating

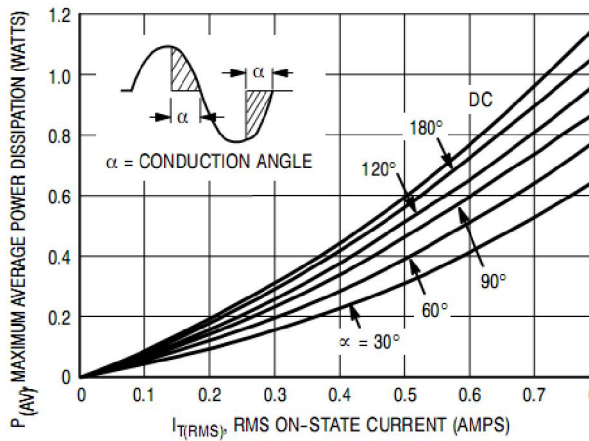

Figure 3. Power Dissipation

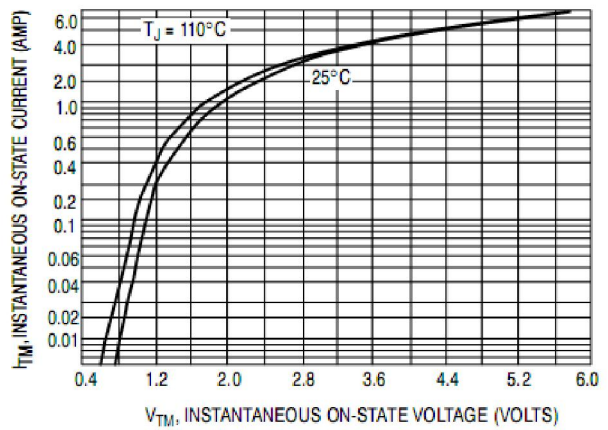

Figure 4. On-State Characteristics

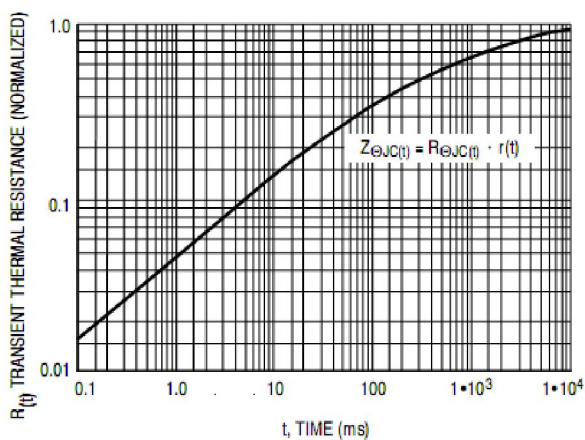

Figure 5. Transient Thermal Response

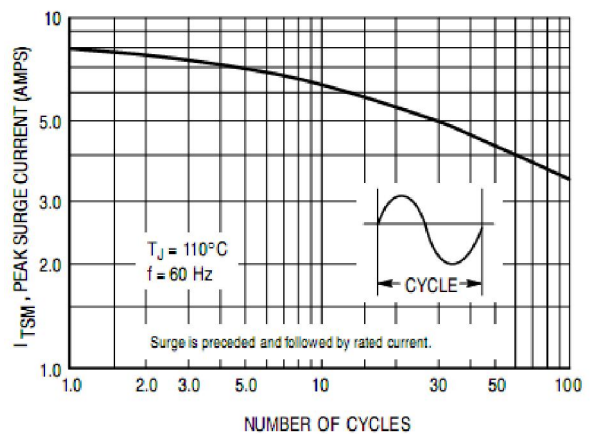

Figure 6. Maximum Allowable Surge Current

Typical Characteristics

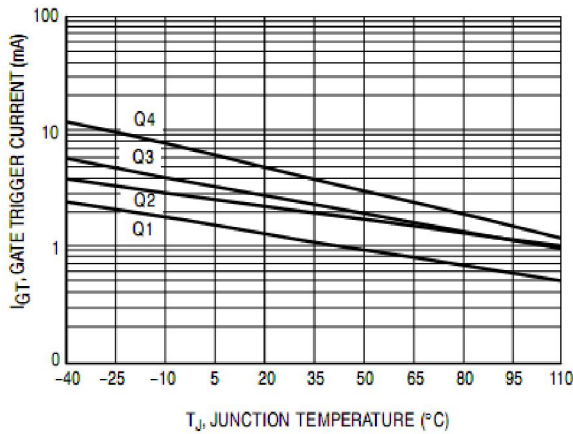

Figure 7. Typical Gate Trigger Current versus Junction Temperature

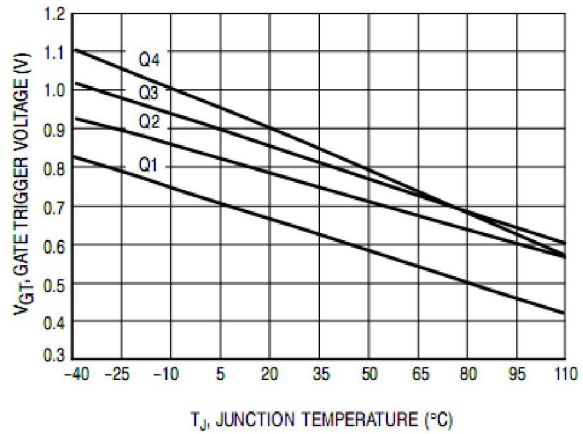

Figure 8. Typical Gate Trigger Voltage versus Junction Temperature

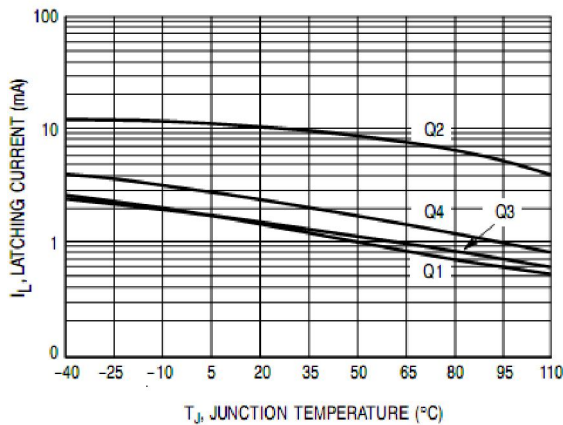

Figure 9. Typical Latching Current versus Junction Temperature

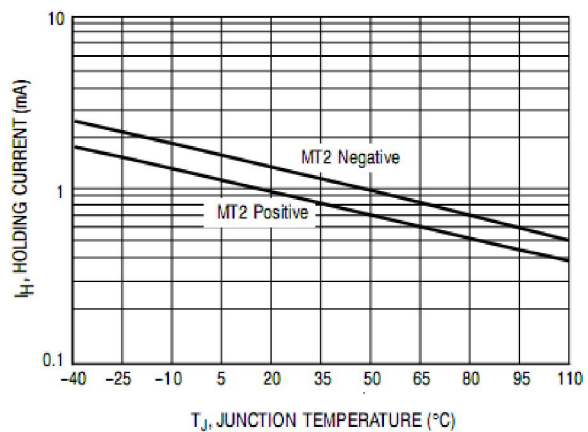

Figure 10. Typical Holding Current versus Junction Temperature

Package Dimensions

TO-92

Symbo	Millimeter		Inches	
	Min.	Max.	Min.	Max.
A	3.30	3.70	0.130	0.146
A1	2.30	2.70	0.091	0.106
b	0.40	0.50	0.016	0.020
b1	0.50	0.70	0.020	0.028
c	0.35	0.45	0.014	0.018
D	4.45	4.70	0.175	0.185
E	4.40	4.65	0.173	0.183
e	1.17	1.37	0.046	0.054
e1	2.34	2.64	0.092	0.104
L	13.50	14.50	0.531	0.571
L1	1.80	2.20	0.071	0.087

单击下面可查看定价，库存，交付和生命周期等信息

[>>YFW\(佑风微\)](#)