

**Transient Voltage Suppressor**

**Features**

- ◆Protects one line
- ◆Working Voltage: 3.3 V
- ◆Low Leakage Current
- ◆Response Time is Typically < 1 ns
- ◆IEC 61000-4-2 ( ESD ) ±8 KV contact ±15 KV Air
- ◆IEC 61000-4-4 (EFT) 40A (5/50ns)

**Application**

- ◆Cellular Handsets & Accessories
- ◆Personal Digital Assistants (PDAs)
- ◆Notebooks & Handhelds
- ◆Portable Instrumentation
- ◆Digital Cameras
- ◆MP3 players

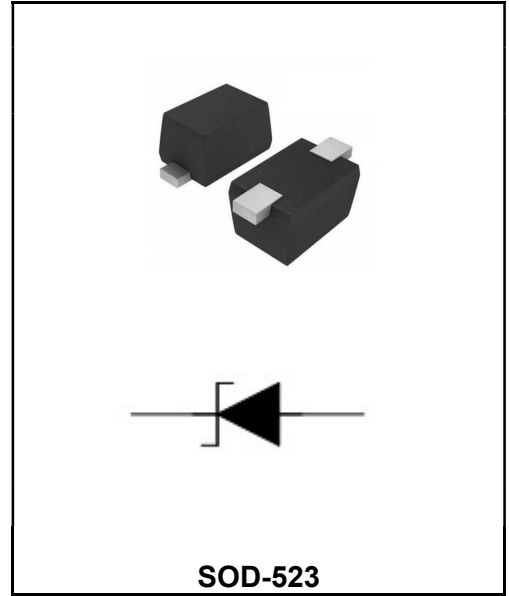

**Order Information**

Part Number	Package	Marking	Size (mm)	Delivery Form	Delivery Quantity
ESD3V3FD523	SOD-523	Z*	1.5X0.65X0.65	7" T&R	3000PCS/Tape

**Limiting Values(TA = 25 °C, unless otherwise specified)**

Symbol	Parameter	Conditions	value	Unit
P <sub>PP</sub>	Peak Pulse Power	tP = 8/20 μs	200	W
V <sub>FP</sub>	Peak Forward Voltage	IF=1 A, tP =8/20μs	1.5	V
T <sub>J</sub>	Junction Temperature	-	-55 to+125	°C
T <sub>stg</sub>	Storage Temperature Range	-	-55 to+150	°C

**Electrical Characteristics(TA = 25 °C unless otherwise specified)**

Symbol	Parameter	Conditions	Min	Typ.	Max	Unit
V <sub>RWM</sub>	Reverse Stand-Off Voltage		-	-	3.3	V
V <sub>BR</sub>	Breakdown Voltage	IT = 1mA	5.0	-	-	V
I <sub>R</sub>	Reverse Leakage Current	VRWM = 3.3 V; TA = 25 °C	-	-	1	uA
I <sub>pp</sub>	Peak Pulse Current	tP =8/20μs	-	-	11.0	A
V <sub>C</sub>	Clamping Voltage	IPP=5 A, tP =8/20μs	-	8.3	-	V
V <sub>C</sub>	Clamping Voltage	IPP=11.0 A, tP =8/20μs	-	14.1	-	V
C <sub>J</sub>	Junction Capacitance	VR = 0V, f = 1 MHz	-	100	-	pF

Typical Characteristics

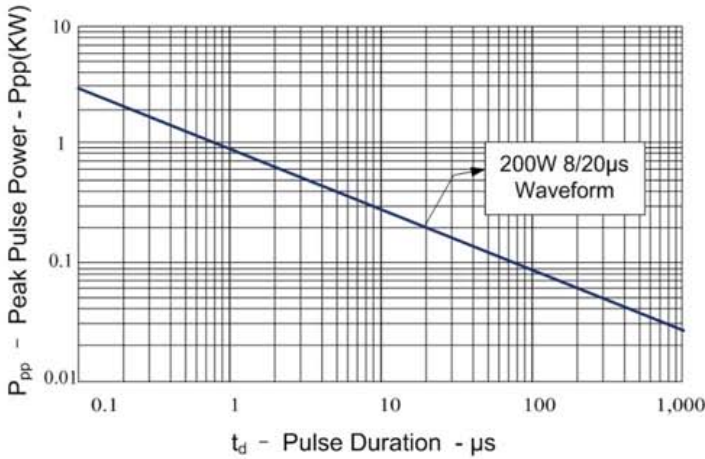

**Fig.1 Peak Pulse Power vs. Pulse Time**

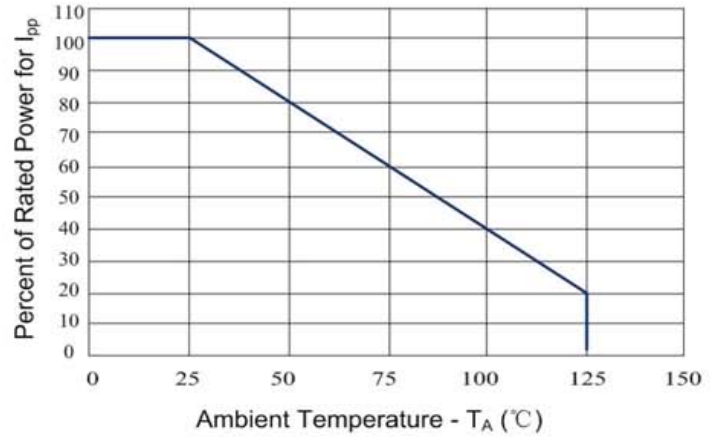

**Fig.2 Power Derating Curve**

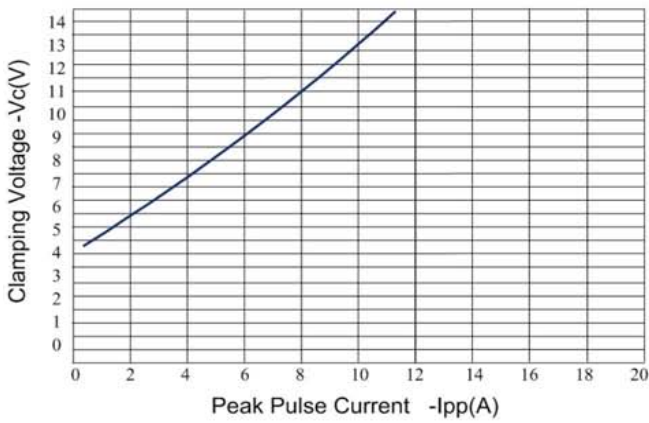

**Fig.3 Clamping Voltage vs. Peak Pulse Current**

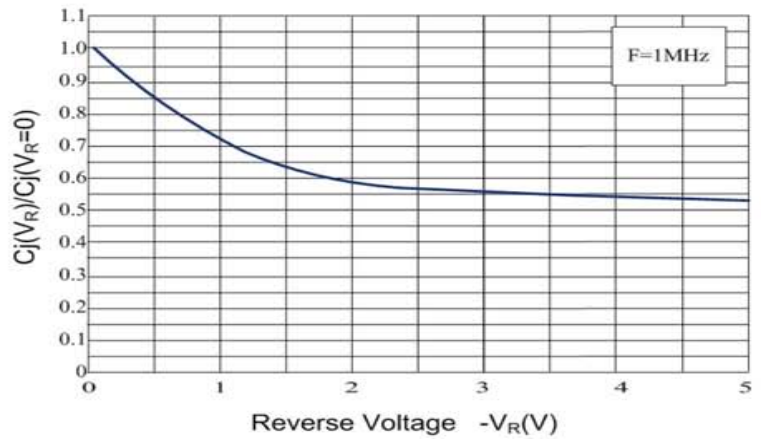

**Fig.4 Normalized Junction Capacitance vs. Reverse Voltage**

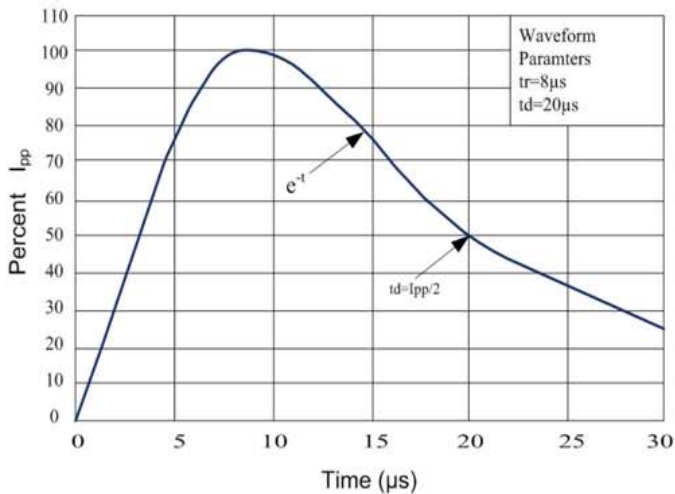

**Fig.5 Pulse Waveform**

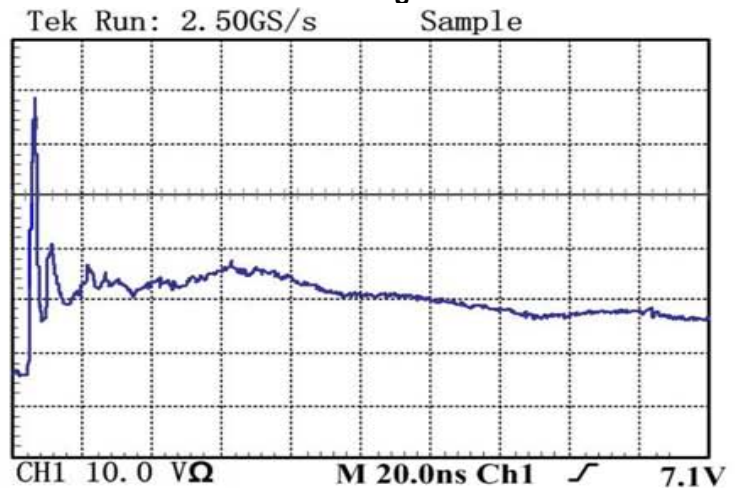

**Fig.6: ESD Clamping( 8kV Contact per IEC 61000-4-2)**

**Electrical Parameters (T=25°C)**

Symbol	Parameter
$I_{PP}$	Maximum Reverse Peak Pulse Current
$V_C$	Clamping Voltage @ $I_{PP}$
$V_{RWM}$	Working Peak Reverse Voltage
$I_R$	Maximum Reverse Leakage Current @ $V_{RWM}$
$V_{BR}$	Breakdown Voltage @ $I_T$
$I_T$	Test Current
$I_F$	Forward Current
$V_F$	Forward Voltage @ $I_F$

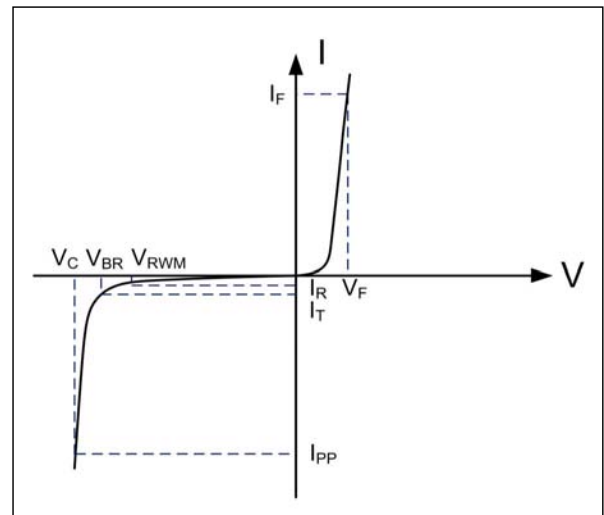

Package Dimension

**PACKAGE OUTLINE**

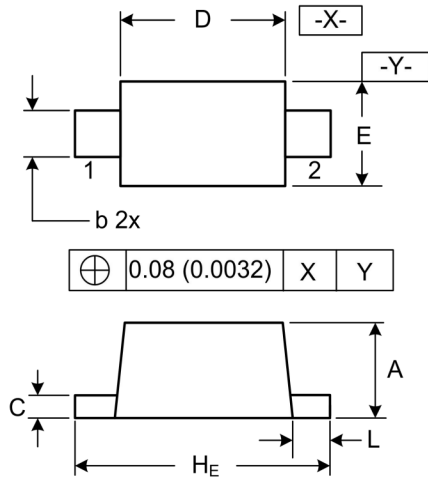

⊕	0.08 (0.0032)	X	Y
---	---------------	---	---

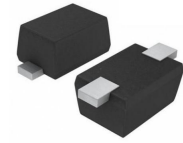

**SOD-523**

**DIMENSIONS**

SYMBOL	MILLIMETER		INCHES	
	MIN	MAX	MIN	MAX
A	0.50	0.70	0.020	0.028
b	0.25	0.35	0.010	0.014
C	0.07	0.20	0.0028	0.0079
D	1.10	1.30	0.043	0.051
E	0.70	0.90	0.028	0.035
H <sub>E</sub>	1.50	1.70	0.059	0.067
L	0.15	0.25	0.006	0.010

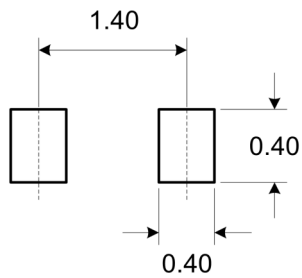

DIMENSIONS: MILLIMETERS

**Notes**

1. Controlling Dimensions in Millimeters.
2. Dimensions are exclusive of mold flash and metal burrs.

单击下面可查看定价，库存，交付和生命周期等信息

[>>YFW\(佑风微\)](#)