

ESDSRVLC05-4

Description

The ESDSRVLC05-4 has ultra low capacitance rail-to-rail diodes with an additional zener diode fabricated in a proprietary silicon avalanche technology to protect each I/O pin providing a high level of protection for electronic equipment that may experience destructive electrostatic discharges (ESD). These robust diodes can safely absorb repetitive ESD strikes at the maximum level (level 4) specified in the IEC 61000-4-2 international standard without performance degradation. Their very low loading capacitance also makes them ideal for protecting high speed signal pins such as HDMI,DVI,USB2.0, and IEEE 1394.

Features

- Case :JEDEC SOT-23-6L package
- Low clamping voltage
- Small packaging options saves board space
- Low capacitance :0.9 pF typical
- Protection for 4 Lines
- Compatible with IEC 61000-4-2(ESD) :Air 18KV , Contact 13KV
- Compatible with IEC 61000-4-5(Surge):5.5A ,8/20 uS - level 2 (line-GND)&Level 3 (Line-Line)

Applications

- USB Power and Data Line Protection
- 10/100/1000 Ethernet
- Video Graphics Cards
- SIM Ports
- ATM Interfaces
- Montors and Flat Panel Displays
- Digital Video Interface(DVI)
- IEEE 1394 Fire wire Ports



Functional Diagram

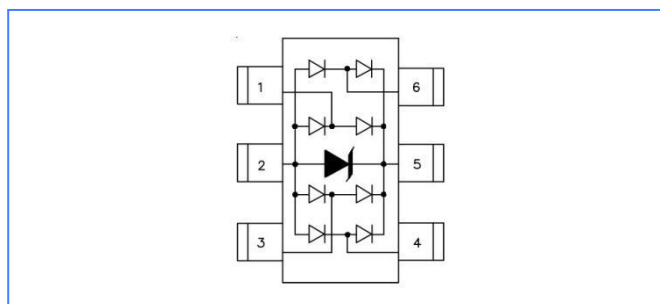

Rail-to-Rail Protection

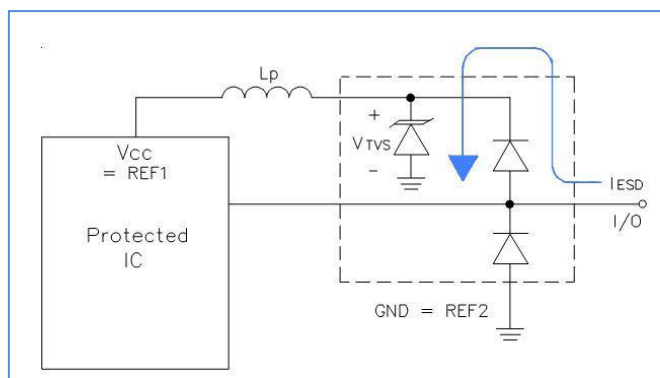

Dual USB Port Protection

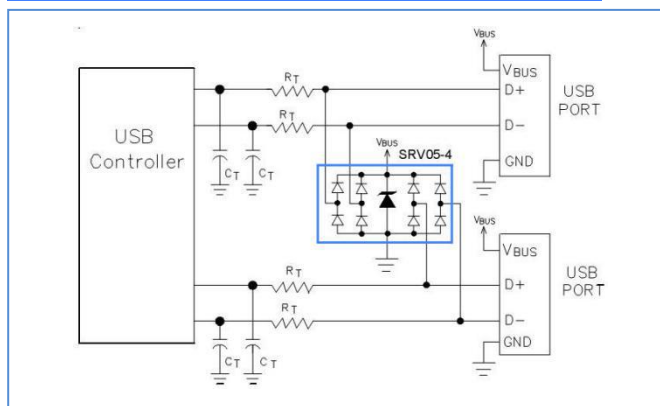

Absolute Maximum Ratings (T_{amb}=25°C unless otherwise specified)

Parameter	Symbol	Value	Units
Peak Current (t _p =8/20 μ s)	P _{PK}	150	W
Peak Current (t _p =8/20 μ s)	I _{PP}	5.5	A
IEC61000-4-2 (Contact)	V _{ESD}	± 13	KV
IEC61000-4-2 (Air)	V _{ESD}	± 18	KV
Lead Soldering Temperature	T _L	260 (10 sec)	° C
Operating Temperature	T _J	-50 to 125	° C
Storage Temperature Range	T _{STG}	-50 to 150	° C

Electrical Characteristics (T_A = 25 °C unless otherwise noted)

Parameter	Symbol	Conditions	Min.	Typ.	Max.	Units
Reverse Stand-off Voltage	V _{RWM}	Any I/O pin to ground			5	V
Reverse Breakdown Voltage	V _{BR}	I _t = 1mA Any I/O pin to ground	6			V
Reverse Leakage Current	I _R	V _{RWM} =5.0V, T=25°C Any I/O pin to ground			1	μ A
Clamping Voltage	V _C	I _{PP} = 1A, t _p =8/20μs Any I/O pin to ground		8.5	12	V
Junction Capacitance	C _{J1}	V _R =0V, f = 1MHz Between I/O pins		0.35	0.45	pF
	C _{J2}	V _R =0V, f = 1MHz Any I/O pin to ground			0.9	pF

Characteristics Curves

Fig1. Non-Repetitive Peak Pulse Power vs. Pulse time

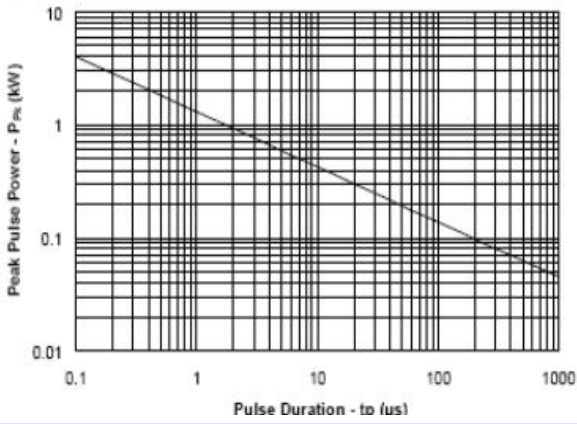

Fig2. Power Derating Curve

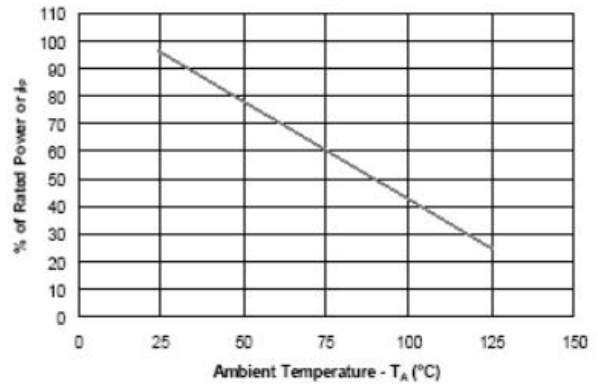

Fig3. Forward Voltage vs. Forward Current

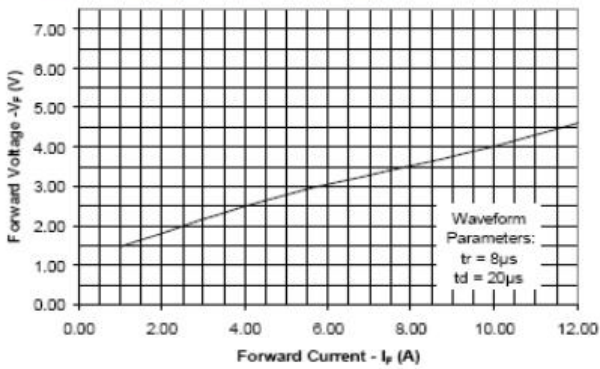

Fig4. Pulse Waveform

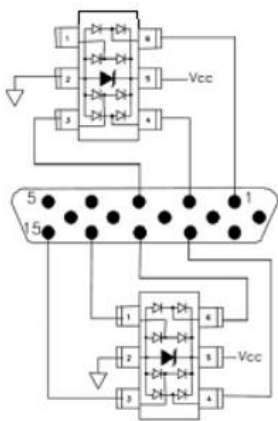
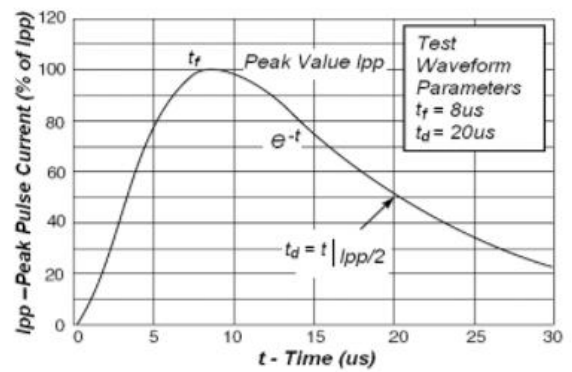

Fig5. Video Interface Protection

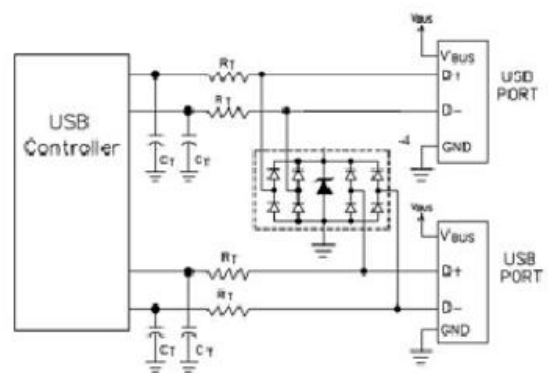

Fig6. Dual USB Port Protection

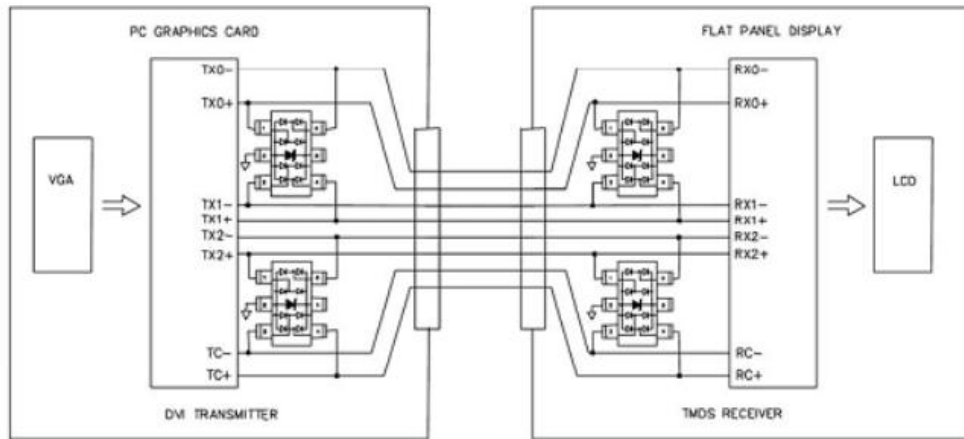
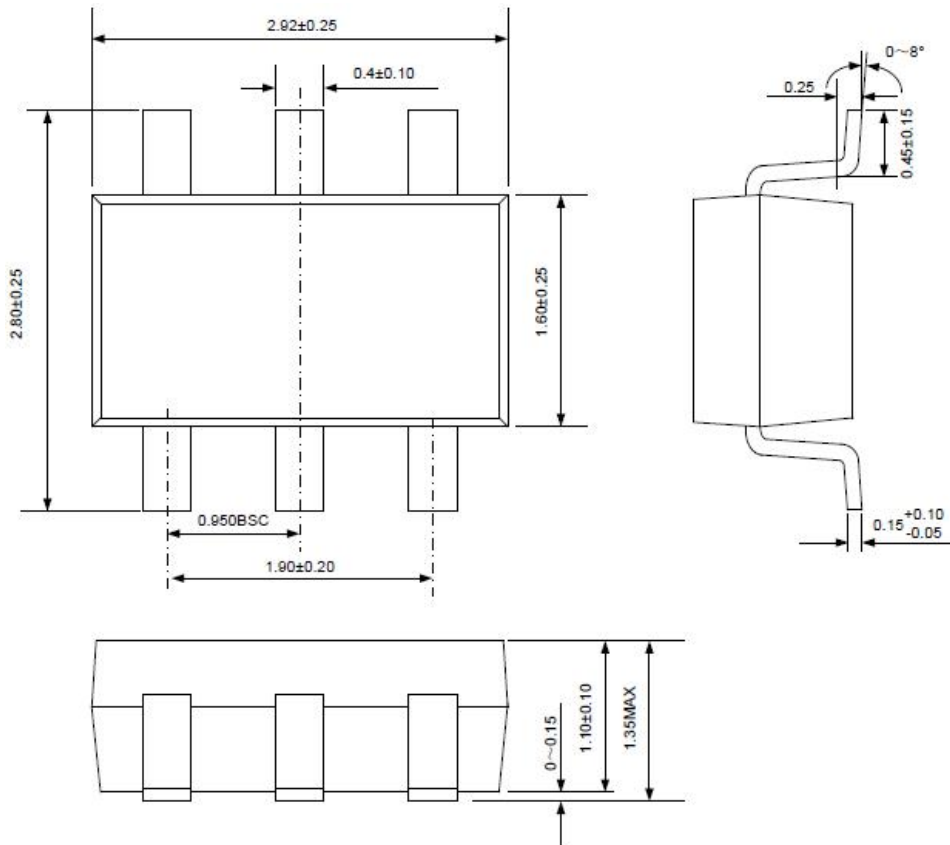

Fig7.Digital Video Interface (DVI) Protection

PACKAGE OUTLINE DIMENSIONS in millimeters:SOT23-6L



Disclaimer

Specifications are subject to change without notice.

The device characteristics and parameters in this data sheet can and do vary in different applications and actual device performance may vary over time.

Users should verify actual device performance in their specific applications.

单击下面可查看定价，库存，交付和生命周期等信息

[>>Yint\(音特电子\)](#)