



LKZ

- ◆ 长寿命 高频低阻抗 低温启动 路灯 室外灯及高端电源专用产品
- ◆ 105℃环境下 12000小时~15000小时
- ◆ 符合AEC-Q200 RoHS指令对应品



■ 主要技术参数

项目	特性									
使用温度范围	≤120V -55℃~+105℃ ; 160V~600V -40℃~+105℃									
标称电压范围	10~600V.DC									
容量允许偏差	±20% (25±2℃ 120Hz)									
漏电流(μA)	10~120V I≤0.01CV or 3μA取大者 C:标称容量(μF) V:额定电压(V) 2分钟读数									
	160~600V I≤0.02CV+10(μA) C:标称容量(μF) V:额定电压(V) 2分钟读数									
损耗角正切值 (25±2℃ 120Hz)	额定电压(V)	10	16	25	35	50	63	80	100	120
	tg δ	0.19	0.16	0.14	0.12	0.12	0.12	0.10	0.10	0.10
	额定电压(V)	160	200	250	350	400	450	500	550	600
	tg δ	0.12	0.15	0.15	0.18	0.20	0.20	0.24	0.25	0.30
标称容量超过1000μF者, 则每增加1000μF, 损耗角正切值增加0.02										
温度特性 (120Hz)	额定电压(V)	10	16	25	35	50	63	80	100	120
	阻抗比Z(-40℃)/Z(20℃)	6	4	3	3	3	3	3	3	5
	额定电压(V)	160	200	250	350	400	450	500	550	600
	阻抗比Z(-40℃)/Z(20℃)	5	5	5	7	7	7	8	16	18
耐久性	在105℃烘箱中, 施加含额定纹波电流的额定电压, 持续规定时间后, 置于常温16小时后测试, 测试温度25±2℃, 电容器的性能应满足如下要求									
	容量变化率	在初始值的±20%以内								
	损耗角正切值	在规定值的200%以下								
	漏电流	在规定值以下								
	负荷寿命	φ8~φ10							12000小时	
	≥φ12.5							15000小时		
高温储存	在105℃下, 储存1000小时, 置于常温16小时后测试, 测试温度25±2℃, 电容器的性能应满足如下要求									
	容量变化率	在初始值的±20%以内								
	损耗角正切值	在规定值的200%以下								
	漏电流	在规定值的200%以下								

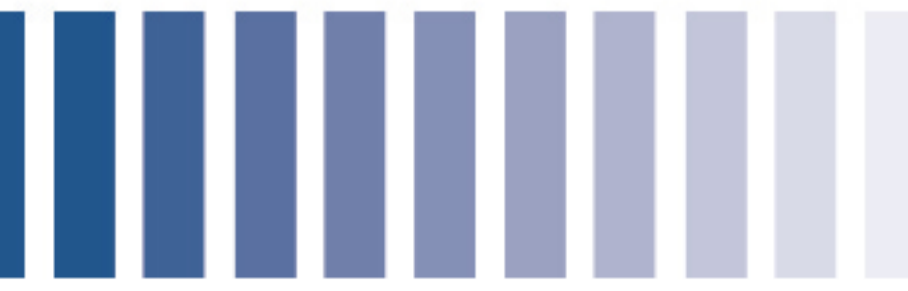

■ 产品尺寸图 (单位: mm)

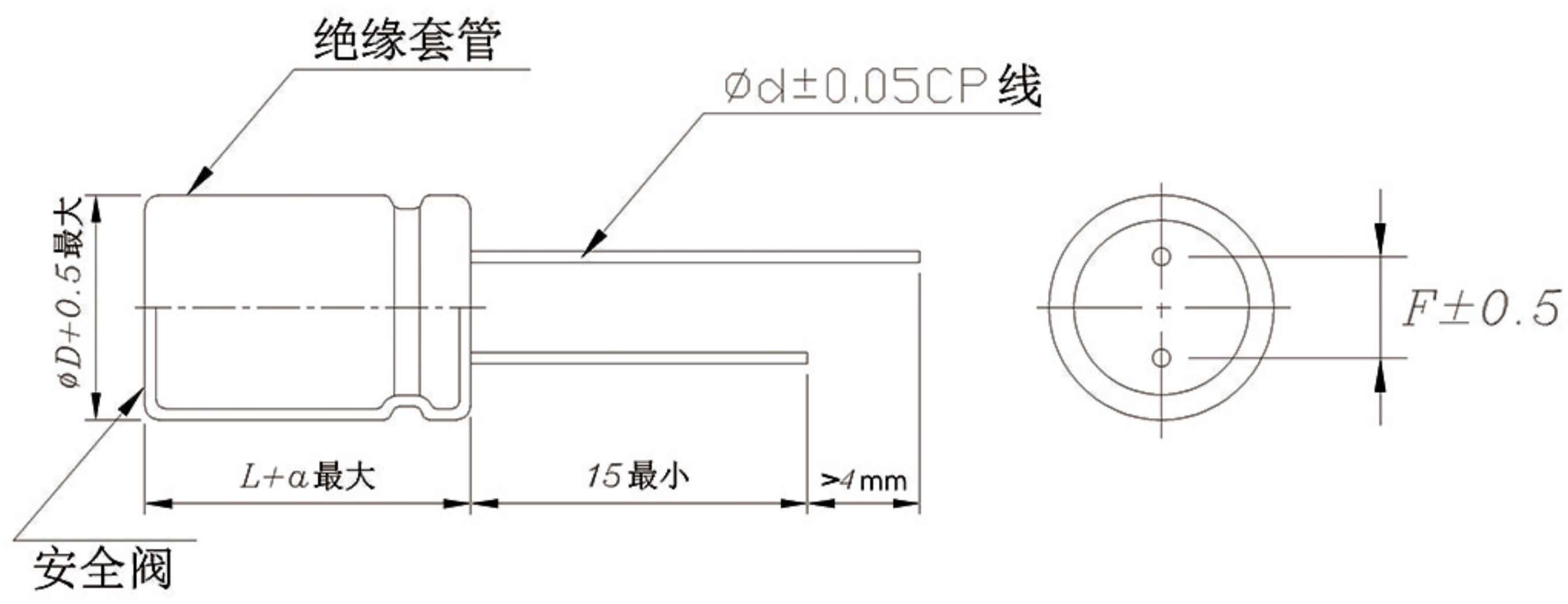

备注: $\geq \phi 6.3$ 产品有安全阀

L=9	a=1.0
L \leq 16	a=1.5
L > 16	a=2.0

D	8	10	12.5	16	18	20	22	25
d	0.6	0.6	0.6	0.8	0.8	0.8	0.8	0.8
F	3.5	5.0	5.0	7.5	7.5	10	10	10

■ 纹波电流补偿系数

① 频率修正系数

频率	50	120	1K	10K ~ 50K	100K
修正因子	0.40	0.50	0.80	0.90	1.00

② 温度修正系数

环境温度(°C)	50°C	70°C	85°C	105°C
修正因子	2.1	1.8	1.4	1.0

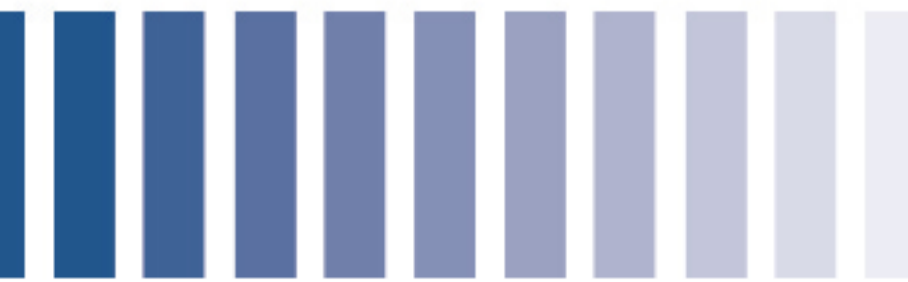

LKZ

■ 标准品一览表

电压(V)	10			16			25			35		
项目 容量 (μF)	尺寸 D×L(mm)	阻抗 ($\Omega_{max}/100kHz$ 25±2℃)	纹波电流 (mA r.m.s/ 105℃ 100kHz)	尺寸 D×L(mm)	阻抗 ($\Omega_{max}/100kHz$ 25±2℃)	纹波电流 (mA r.m.s/ 105℃ 100kHz)	尺寸 D×L(mm)	阻抗 ($\Omega_{max}/100kHz$ 25±2℃)	纹波电流 (mA r.m.s/ 105℃ 100kHz)	尺寸 D×L(mm)	阻抗 ($\Omega_{max}/100kHz$ 25±2℃)	纹波电流 (mA r.m.s/ 105℃ 100kHz)
150										8×11.5	3.600	1008
150										10×9	3.500	1029
180										8×14	2.820	1008
180										10×9	2.820	1029
220							8×11.5	3.600	1008	8×16	2.500	1334
220							10×9	3.500	1029	10×12.5	2.500	1334
270							8×11.5	3.500	1008	8×16	1.9530	1334
270							10×9	3.500	1029	10×12.5	1.9530	1397
330							8×14	2.200	1008	10×12.5	1.9530	1397
390				8×11.5	3.600	1008	8×16	0.2800	1334	10×16	1.5258	1943
390				10×9	3.500	1029	10×12.5	0.2800	1334			
470				8×11.5	2.820	1008	10×12.5	0.2800	1397	10×16	1.1920	1943
470				10×9	2.820	1029						
560	8×11.5	0.2180	1008	8×16	0.2800	1334	8×20	0.2500	1607	10×20	0.1150	2363
560	10×9	0.2180	1029	10×12.5	0.2800	1397	10×16	0.2500	1943	12.5×16	0.1150	2447
680	8×11.5	0.2180	1008	8×16	0.2800	1334	10×16	0.2500	1943	10×23	0.1100	2447
680	10×9	0.2180	1029	10×12.5	0.2800	1397				12.5×16	0.1150	2447
820	8×14	0.1702	1229	8×20	0.2188	1607	10×20	0.1953	2363	12.5×20	0.0950	2604
820	10×12.5	0.1702	1334	10×16	0.2188	1943	12.5×16	0.1953	2447			
1000	8×16	0.1330	1334	8×20	0.1708	1607	10×23	0.1526	2447	12.5×20	0.0950	2604
1000	10×12.5	0.1330	1397	10×16	0.1708	1943	12.5×16	0.1526	2447			
1200	8×20	0.1039	1607	10×20	0.0730	2058	12.5×20	0.0800	2604	12.5×25	0.0810	3045
1200	10×14	0.1039	1848	12.5×16	0.0730	2447						
1500	8×20	0.0934	1607	10×20	0.0730	2058	12.5×20	0.0650	2604	12.5×30	0.0452	3623
1500	10×16	0.0934	1943	12.5×16	0.0730	2447				16×20	0.0452	3413
1800	10×20	0.0730	2058	10×23	0.0570	2363	12.5×25	0.0500	3045	12.5×35	0.0430	3749
1800	12.5×16	0.0730	2447	12.5×20	0.0570	2604				16×25	0.0430	3812
2200	10×20	0.0730	2058	12.5×20	0.0570	2604	12.5×30	0.0456	3623	16×25	0.0410	3812
2200	12.5×16	0.0570	2447				16×20	0.0456	3413			
2700	10×23	0.0446	2363	12.5×25	0.0400	3045	12.5×35	0.0412	3749	16×35.5	0.0400	4211
2700	12.5×20	0.0446	2604				16×25	0.0412	3812	18×31.5	0.0400	4389
3300	12.5×20	0.0446	2604	12.5×30	0.0380	3623	12.5×40	0.0380	4085	16×40	0.0280	4431
3300				16×20	0.0380	3413	16×25	0.0380	3812	18×35.5	0.0280	4431
3900	12.5×25	0.0400	3045	12.5×30	0.0380	3623	16×31.5	0.0340	4085	18×40	0.0218	4725
3900				16×20	0.0380	3413	18×25	0.0340	4085			
4700	12.5×30	0.0390	3623	12.5×35	0.0360	3749	16×35.5	0.0310	4211			
4700	16×20	0.0390	3623	16×25	0.0360	3812	18×31.5	0.0310	4389			
5600	16×25	0.0380	3749	16×31.5	0.0340	4085	18×35.5	0.0280	4431			
5600	18×20	0.0380	3749	18×25	0.0340	4085						
6800	16×31.5	0.0340	3812	16×35.5	0.0310	4211	18×40	0.0218	4725			
6800	18×25	0.0340	3812	18×31.5	0.0310	4389						

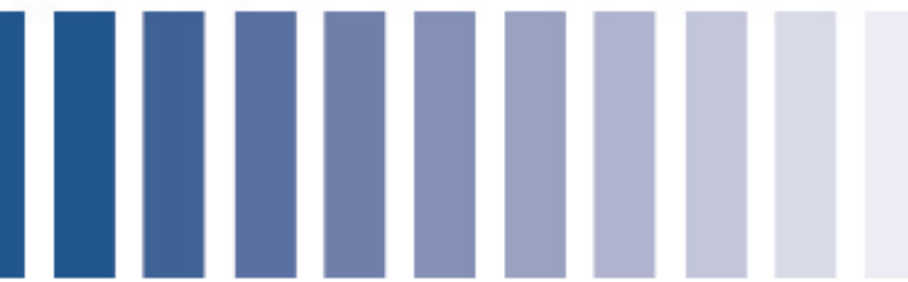

LKZ

■ 标准品一览表

电压(V)	50			63			80			100		
项目 容量 (μF)	尺寸 D×L(mm)	阻抗 ($\Omega_{max/100kHz}$ 25±2℃)	纹波电流 (mA r.m.s/ 105℃ 100kHz)	尺寸 D×L(mm)	阻抗 ($\Omega_{max/100kHz}$ 25±2℃)	纹波电流 (mA r.m.s/ 105℃ 100kHz)	尺寸 D×L(mm)	阻抗 ($\Omega_{max/100kHz}$ 25±2℃)	纹波电流 (mA r.m.s/ 105℃ 100kHz)	尺寸 D×L(mm)	阻抗 ($\Omega_{max/100kHz}$ 25±2℃)	纹波电流 (mA r.m.s/ 105℃ 100kHz)
15										8×11.5	2.70	485
15										10×9	2.70	525
18										8×11.5	2.70	485
18										10×9	2.70	525
22										8×11.5	2.70	485
22										10×9	2.70	525
27										8×16	2.00	614
27										10×12.5	2.00	655
33							8×11.5	2.60	485	8×16	2.00	614
33							10×9	2.60	525	10×12.5	2.00	655
39							8×11.5	2.09	485	8×16	1.56	614
39							10×9	2.09	525	10×12.5	1.56	655
47				8×11.5	2.6	546	8×11.5	1.50	485	10×12.5	1.56	655
47				10×9	2.6	562						
56				8×11.5	2.6	546	8×16	1.20	614	10×12.5	1.20	788
56				10×9	2.6	562	10×12.5	1.20	614			
68				8×11.5	2.09	546	8×16	1.20	614	8×20	1.00	809
68				10×9	2.09	562	10×12.5	1.20	655	10×16	1.00	819
82	8×11.5	2.60	777	8×16	1.50	758	10×12.5	1.20	655	10×16	1.00	819
82	10×9	2.60	699	10×12.5	1.50	683						
100	8×11.5	2.09	777	8×16	1.50	758	8×20	1.00	840	10×20	0.78	1092
100	10×9	2.09	699	10×12.5	1.50	758	10×16	1.00	819	12.5×16	0.78	1024
120	8×16	1.5000	1019	10×12.5	1.50	758	10×16	1.00	819	10×23	0.500	1229
120	10×12.5	1.5000	1034				8×20	1.00	819	12.5×20	0.500	1502
150	8×16	1.5000	1019	8×20	1.20	935	10×20	0.80	1092	12.5×20	0.500	1502
150	10×12.5	1.5000	1034	10×16	1.20	1048	12.5×16	0.80	1024			
180	8×20	1.3400	1281	10×16	1.20	1048	10×20	0.80	1092	12.5×25	0.4600	1701
180	10×16	1.3400	1439				12.5×16	0.80	1024			
220	8×20	1.3400	1281	10×20	0.9300	1260	10×23	0.60	1229	12.5×25	0.4600	1701
220	10×16	1.3400	1439	12.5×16	0.9300	1313	12.5×20	0.60	1502			
270	10×20	0.9300	1659	10×20	0.9300	1260	12.5×20	0.60	1502	12.5×30	0.4400	2048
270	12.5×16	0.9300	1840	12.5×16	0.8040	1313				16×20	0.4400	1838
330	10×20	0.9300	1659	10×23	0.7600	1481	12.5×25	0.5400	1701	12.5×35	0.4000	2247
330	12.5×16	0.8000	1840	12.5×20	0.5000	1649				16×25	0.4000	2321
390	10×23	0.7600	1964	12.5×20	0.5000	1649	12.5×30	0.4900	2048	12.5×40	0.3200	2457
390	12.5×20	0.5000	2153				16×20	0.4900	1838	16×25	0.3200	2321
470	12.5×20	0.5000	2153	12.5×25	0.4500	2090	12.5×35	0.4500	2247	16×31.5	0.1000	2520
470							16×25	0.4500	2321	18×25	0.1000	2384
560	12.5×25	0.3900	2531	12.5×30	0.4400	2531	12.5×40	0.4400	2457	16×35.5	0.0920	2730

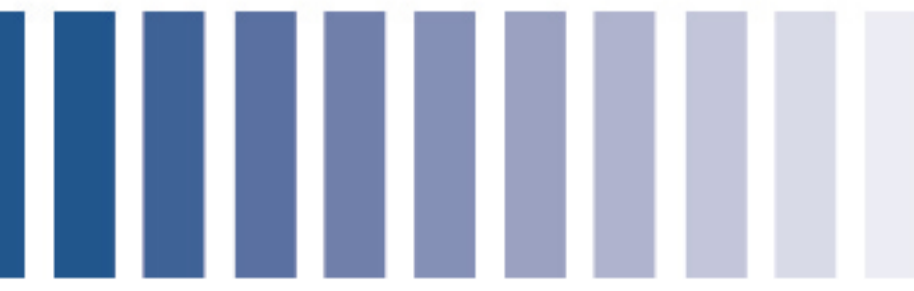

LKZ

■ 标准品一览表

电压(V)	50			63			80			100		
项目 容量 (μF)	尺寸 D×L(mm)	阻抗 ($\Omega_{max}/100KHz$ 25±2℃)	纹波电流 (mA r.m.s/ 105℃ 100KHz)	尺寸 D×L(mm)	阻抗 ($\Omega_{max}/100KHz$ 25±2℃)	纹波电流 (mA r.m.s/ 105℃ 100KHz)	尺寸 D×L(mm)	阻抗 ($\Omega_{max}/100KHz$ 25±2℃)	纹波电流 (mA r.m.s/ 105℃ 100KHz)	尺寸 D×L(mm)	阻抗 ($\Omega_{max}/100KHz$ 25±2℃)	纹波电流 (mA r.m.s/ 105℃ 100KHz)
560				16×20	0.4400	2531	16×25	0.4400	2321	18×31.5	0.0920	2594
680	12.5×25	0.3050	2531	12.5×35	0.4300	2751	16×31.5	0.4300	2520	16×40	0.0840	3003
680				16×25	0.4300	2867	18×25	0.4300	2384	18×35.5	0.0840	3003
820	12.5×30	0.2380	3108	12.5×40	0.4200	3087	16×35.5	0.4200	2730	18×40	0.0660	3686
820	16×20	0.2380	2867	16×25	0.4200	2867	18×25	0.4200	2384			
1000	12.5×35	0.0500	3108	16×31.5	0.4100	3140	16×40	0.4100	3003			
1000	16×25	0.0500	3161	18×25	0.4100	2940	18×31.5	0.4100	2594			
1200	16×31.5	0.0390	3444	16×31.5	0.4100	3140	18×35.5	0.4000	3003			
1200	18×25	0.0390	3213	18×25	0.4100	2940						
1500	16×35.5	0.0350	3192	16×35.5	0.4000	3192	18×40	0.3900	3686			
1500	18×31.5	0.0350	3465	18×31.5	0.4000	3465						
1800	16×35.5	0.0350	3192	16×40	0.3900	3749						
1800	18×31.5	0.0350	3465	18×35.5	0.3900	3749						
2200	18×35.5	0.0318	3749	18×40	0.3800	4095						
2700	18×40	0.0290	4095									

电压(V)	120			160			200			250		
项目 容量 (μF)	尺寸 D×L(mm)	阻抗 ($\Omega_{max}/100KHz$ 25±2℃)	纹波电流 (mA r.m.s/ 105℃ 100KHz)	尺寸 D×L(mm)	阻抗 ($\Omega_{max}/100KHz$ 25±2℃)	纹波电流 (mA r.m.s/ 105℃ 100KHz)	尺寸 D×L(mm)	阻抗 ($\Omega_{max}/100KHz$ 25±2℃)	纹波电流 (mA r.m.s/ 105℃ 100KHz)	尺寸 D×L(mm)	阻抗 ($\Omega_{max}/100KHz$ 25±2℃)	纹波电流 (mA r.m.s/ 105℃ 100KHz)
6.8										8×11.5	10.15	168
6.8										10×9	10.15	151
8.2							8×11.5	10.15	168	8×11.5	10.15	168
8.2							10×9	10.15	189	10×9	10.15	151
10							8×11.5	10.15	179	8×14	9.50	305
10							10×9	10.15	189	10×12.5	4.50	383
12				8×11.5	10.15	176	8×14	8.75	240	8×16	4.05	305
15	8×11.5	4.00	429	8×11.5	10.00	274	8×16	3.24	305	8×16	3.65	305
15	10×9	4.00	455	10×9	10.00	274	10×12.5	4.50	383	10×14	3.24	399
18	8×11.5	4.00	429	8×14	7.50	305	8×20	3.24	389	8×20	3.24	389
18	10×9	4.00	455	10×12.5	7.50	274	10×14	3.24	399	10×16	3.24	420
22	8×14	3.60	478	8×20	4.27	368	8×20	3.24	389	10×16	3.24	420
22	10×9	4.00	519	10×12.5	7.50	399	10×16	3.24	420			
27	8×16	3.00	543	8×20	2.65	368	10×20	2.53	466	10×20	2.53	466
27	10×12.5	3.00	579	10×12.5	2.65	399	12.5×14	2.53	665	12.5×16	2.53	665
33	8×16	3.00	543	10×16	2.65	683	10×20	1.65	683	10×20	1.65	683
33	10×12.5	3.00	579	12.5×14	2.65	798	12.5×14	1.65	798	12.5×16	1.65	798

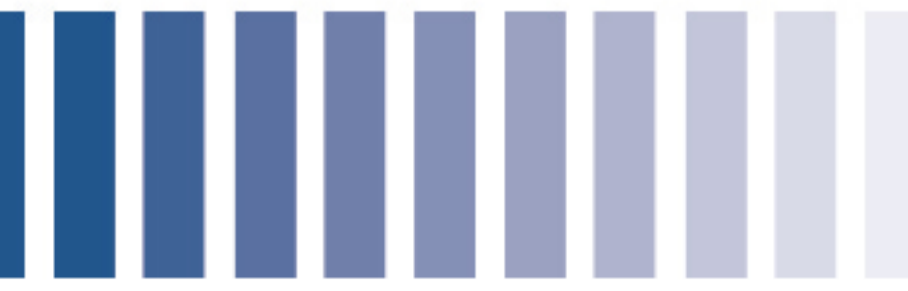

LKZ

■ 标准品一览表

电压(V)	120			160			200			250		
项目 容量 (μF)	尺寸 D×L(mm)	阻抗 ($\Omega_{max}/100KHz$ 25±2℃)	纹波电流 (mA r.m.s/ 105℃ 100KHz)	尺寸 D×L(mm)	阻抗 ($\Omega_{max}/100KHz$ 25±2℃)	纹波电流 (mA r.m.s/ 105℃ 100KHz)	尺寸 D×L(mm)	阻抗 ($\Omega_{max}/100KHz$ 25±2℃)	纹波电流 (mA r.m.s/ 105℃ 100KHz)	尺寸 D×L(mm)	阻抗 ($\Omega_{max}/100KHz$ 25±2℃)	纹波电流 (mA r.m.s/ 105℃ 100KHz)
39	8×20	2.65	597	10×16	2.65	683	12.5×20	1.50	958	12.5×20	1.5	958
39	10×14	2.65	636	12.5×14	2.65	798						
47	10×14	2.65	636	10×20	2.65	788	12.5×20	1.50	1029	12.5×20	1.38	1029
47				12.5×14	2.65	798						
56	10×16	2.21	720	10×20	2.65	966	12.5×20	1.38	1029	12.5×20	1.38	1029
56	12.5×14	2.20	756	12.5×16	2.27	1239						
68	10×20	2.00	792	12.5×20	2.27	1344	12.5×25	1.25	1365	12.5×25	1.25	1365
68	12.5×14	2.20	792				16×20	1.25	1491	16×20	1.25	1491
82	12.5×16	2.00	880	12.5×20	2.27	1344	12.5×30	1.25	1460	12.5×30	1.15	1460
82							16×20	1.18	1491	16×20	1.18	1491
100	12.5×20	1.80	1161	12.5×20	2.27	1344	12.5×25	1.15	1460	16×25	1.18	2048
100										18×20	1.02	2048
120	12.5×20	1.80	1340	12.5×25	1.43	1628	16×20	1.18	2048	16×25	1.02	2048
120				16×20	1.25	1491				18×20	1.02	2090
150	12.5×25	1.60	1463	12.5×25	1.43	2058	16×25	1.18	2252	16×31.5	0.98	2132
150	16×20	1.60	1524				18×20	1.18	2252	18×25	0.98	2132
180	16×20	1.43	1731	16×20	1.43	1985	16×35.5	0.92	2415	18×25	0.80	2415
180							18×25	0.92	2415			
220	16×25	1.19	2078	16×25	1.14	2573	16×35.5	0.80	2415	18×31.5	0.74	2814
220	18×20	1.19	2078	18×20	1.14	2489	18×31.5	0.80	2415			
270	16×31.5	1.10	2490	16×31.5	1.14	2573	16×40	0.74	2656			
270	18×25	1.10	2490				18×31.5	0.74	2656			
330	16×31.5	1.10	2520	16×31.5	1.10	3360	16×40	0.74	2898			
330	18×25	1.10	2520	18×25	1.10	3360	18×31.5	0.74	2898			
390	16×35.5	1.00	2730	16×35.5	0.95	3623	16×45	0.62	3188			
390	18×31.5	1.00	2730	18×31.5	0.95	3623	18×35.5	0.62	3188			
470	18×35.5	0.90	3003	18×35.5	0.90	3819	18×40	0.56	3623			
560	18×40	0.84	3686	18×40	0.85	3919	18×45	0.44	3969			

电压(V)	350			400			450			500		
项目 容量 (μF)	尺寸 D×L(mm)	阻抗 ($\Omega_{max}/100KHz$ 25±2℃)	纹波电流 (mA r.m.s/ 105℃ 100KHz)	尺寸 D×L(mm)	阻抗 ($\Omega_{max}/100KHz$ 25±2℃)	纹波电流 (mA r.m.s/ 105℃ 100KHz)	尺寸 D×L(mm)	阻抗 ($\Omega_{max}/100KHz$ 25±2℃)	纹波电流 (mA r.m.s/ 105℃ 100KHz)	尺寸 D×L(mm)	阻抗 ($\Omega_{max}/100KHz$ 25±2℃)	纹波电流 (mA r.m.s/ 105℃ 100KHz)
2.2										8×14	16.50	95
2.7										8×16	12.00	116
3.3				8×11.5	16.00	168	8×11.5	28.00	147	8×16	12.00	116
3.3				10×9	16.00	189	10×9	28.00	158			

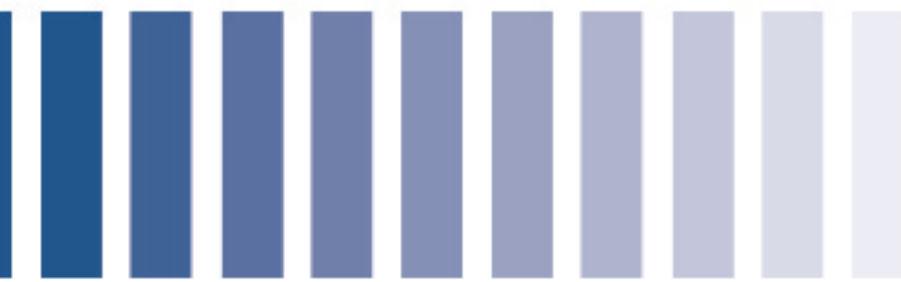

LKZ

■ 标准品一览表

电压(V)	350			400			450			500		
项目 容量 (μF)	尺寸 D×L(mm)	阻抗 ($\Omega_{max}/100KHz$ 25±2℃)	纹波电流 (mA r.m.s/ 105℃ 100KHz)	尺寸 D×L(mm)	阻抗 ($\Omega_{max}/100KHz$ 25±2℃)	纹波电流 (mA r.m.s/ 105℃ 100KHz)	尺寸 D×L(mm)	阻抗 ($\Omega_{max}/100KHz$ 25±2℃)	纹波电流 (mA r.m.s/ 105℃ 100KHz)	尺寸 D×L(mm)	阻抗 ($\Omega_{max}/100KHz$ 25±2℃)	纹波电流 (mA r.m.s/ 105℃ 100KHz)
3.9	8×11.5	16.00	163	8×11.5	16.00	168	8×11.5	28.00	147	8×20	12.00	137
3.9	10×9	16.00	179	10×9	16.00	231	10×9	28.00	158	10×16	12.00	137
4.7	8×11.5	16.00	163	8×11.5	16.00	168	8×14	21.80	184	8×20	12.00	137
4.7	10×9	16.00	189	10×9	16.00	231	10×12.5	21.80	189	10×16	12.00	137
5.6	8×14	12.50	210	8×14	12.50	252	8×16	12.50	200	10×16	12.00	147
5.6	10×9	16.00	179	10×12.5	12.50	263	10×12.5	12.50	210			
6.8	8×16	10.50	231	8×16	10.50	284	8×20	9.80	242	10×20	11.00	263
6.8	10×12.5	12.50	252	10×12.5	10.50	294	10×14	9.80	221	12.5×14	11.00	263
8.2	8×20	7.50	305	8×20	7.50	305	10×16	6.20	242	10×20	11.00	263
8.2	10×12.5	12.50	331	10×14	7.50	331				12.5×16	10.00	294
10	8×20	12.50	305	10×16	7.50	368	10×16	6.20	242	10×23	10.00	294
10	10×14	7.50	368				12.5×14	6.20	378	12.5×20	7.00	336
12	10×20	7.00	375	10×20	6.20	420	12.5×16	6.20	483	12.5×25	6.00	504
15	10×20	6.20	389	10×20	6.20	515	10×23	6.20	431	12.5×25	6.00	504
15	12.5×14	6.20	515	12.5×16	6.20	578	12.5×16	6.20	483	16×20	6.00	462
18	10×20	6.20	515	10×20	6.20	515	12.5×20	4.50	525	12.5×25	6.00	504
18	12.5×16	6.20	536	12.5×16	6.20	578				16×20	6.00	462
22	10×23	6.20	578	12.5×20	6.20	693	12.5×20	4.25	525	12.5×30	4.50	546
22	12.5×20	6.20	693							16×25	2.80	735
27	12.5×20	4.84	833	12.5×25	4.84	833						
27				16×20	5.84	1113						
33	12.5×20	2.25	1113	12.5×25	4.00	1113	12.5×30	2.82	809	16×31.5	2.20	777
33				16×20	3.00	1208	16×20	3.00	767	18×25	2.20	777
39	12.5×25	2.25	1208	16×25	2.00	1239						
39	16×20	2.25	1208	18×20	2.00	1239						
47	12.5×25	2.25	1208	16×25	2.00	1239	16×25	2.82	1302	16×35.5	2.00	893
47	16×20	2.25	1208	18×20	2.00	1239	18×20	2.82	1260	18×31.5	2.00	893
56	12.5×30	2.02	1281	16×31.5	1.82	1659	16×31.5	1.50	1302	18×31.5	2.00	1070
56	16×25	2.02	1386	18×25	1.82	1607	18×25	1.50	1260			
68	16×31.5	1.38	1659	16×31.5	1.38	1659	16×35.5	1.25	1470	18×35.5	1.50	1260
68	18×20	1.38	1607	18×25	1.38	1607	18×31.5	1.25	1533			
82	16×31.5	1.38	1659	16×35.5	1.25	2394	18×31.5	1.25	1533	18×35.5	1.50	1260
82	18×25	1.38	1607	18×31.5	1.25	2394						
100	16×40	1.25	2042	18×35.5	1.07	2919	18×40	0.90	2069	18×40	1.30	1329
100	18×31.5	1.25	2394									
120	18×35.5	1.25	2919	18×40	0.95	2993	18×45	0.85	2184	20×40	1.10	1466
150	18×40	0.97	2919	18×45	0.90	3128						
180	18×45	0.85	3211									

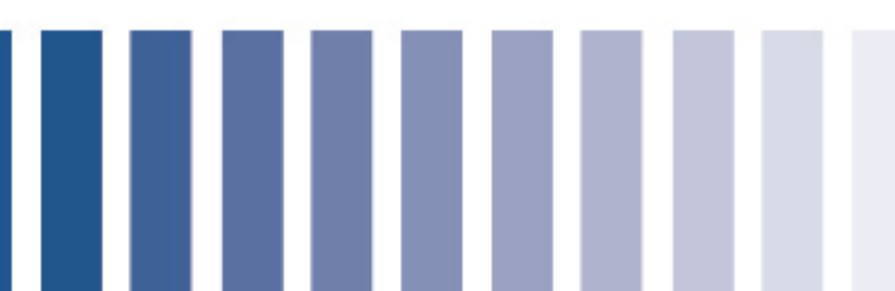

LKZ

■ 标准品一览表

电压(V)	550			600		
项目 容量 (μF)	尺寸 D×L(mm)	阻抗 ($\Omega_{max}/100KHz$ 25±2℃)	纹波电流 (mA r.m.s/ 105℃ 100KHz)	尺寸 D×L(mm)	阻抗 ($\Omega_{max}/100KHz$ 25±2℃)	纹波电流 (mA r.m.s/ 105℃ 100KHz)
2.2	8×14	27.7	66	8×14	29.4	61
2.7	8×16	20.2	81	8×16	21.4	75
3.3	8×16	20.2	81	8×16	21.4	75
3.9	8×20	20.2	96	8×20	21.4	89
3.9	10×16	20.2	96	10×16	21.4	89
4.7	8×20	20.2	96	8×20	21.4	89
4.7	10×16	20.2	96	10×16	21.4	89
5.6	10×16	20.2	103	10×16	21.4	96
6.8	10×20	18.5	184	10×20	19.6	171
6.8	12.5×14	18.5	184	12.5×14	19.6	171
8.2	10×20	18.5	184	10×20	19.6	171
8.2	12.5×16	16.8	206	12.5×16	17.8	191
10	10×23	16.8	206	10×23	17.8	191
10	12.5×20	11.8	235	12.5×20	12.5	218
12	12.5×25	10.1	353	12.5×25	10.7	328
15	12.5×25	10.1	353	12.5×25	10.7	328
15	16×20	10.1	323	16×20	10.7	300
18	12.5×25	10.1	353	12.5×25	10.7	328
18	16×20	10.1	323	16×20	10.7	300
22	12.5×30	7.6	382	12.5×30	8.0	355
22	16×25	4.7	515	16×25	8.0	478
33	16×31.5	3.7	544	16×31.5	3.9	505
33	18×25	3.7	544	18×25	3.9	505
47	16×35.5	3.4	625	16×35.5	3.6	580
47	18×31.5	3.4	625	18×31.5	3.6	580
56	18×31.5	3.4	625	18×35.5	3.6	640
68	18×35.5	2.5	882	18×40	2.7	819
82	18×40	2.5	970	20×40	2.7	900
100	20×40	2.2	1060	22×40	2.3	990
120	22×40	1.8	1170	25×40	1.8	1090

单击下面可查看定价，库存，交付和生命周期等信息

[>>YMIN\(上海永铭\)](#)