

CRYSTAL UNIT

HC-49XSMD

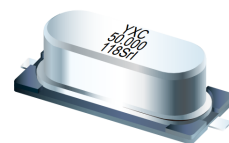

Applications

- Industrial Control Consumers .

Features

- Dimensions:6.10 x 4.00 x2.0 mm.
- Frequency range:8~50MHz
- Surface mount type crystal units.
- A great number of standard frequencies.

Specifications

Standard Frequency	8~50 MHz
Vibration Mode	AT Fundamental
Load Capacitance	12pF,20pF,or specify
Frequency Tolerance (at 25)	±10ppm,±20ppm,or specify
Frequency Versus Temperature Characteristics	±20ppm,or specify
Operating Temperature	-20~+70℃, -40~+85℃, or specify
Storage Temperature	-40~+85℃ or specify
Shunt Capacitance	5 pF Max.
Level of Drive	1~500μWMax.(100uW typical)
Aging (at 25 °C)	±3ppm/year Max.

Equivalent Series Resistance(ESR)

Fundamental			
8 ~ 11.999MHz	80 Ω Max.	16 ~ 19.000 MHz	50 Ω Max.
12 ~ 15.999MHz	60 Ω Max.	20 ~ 50.00MHz	40 Ω Max.

Dimensions and Patterns [unit:mm]

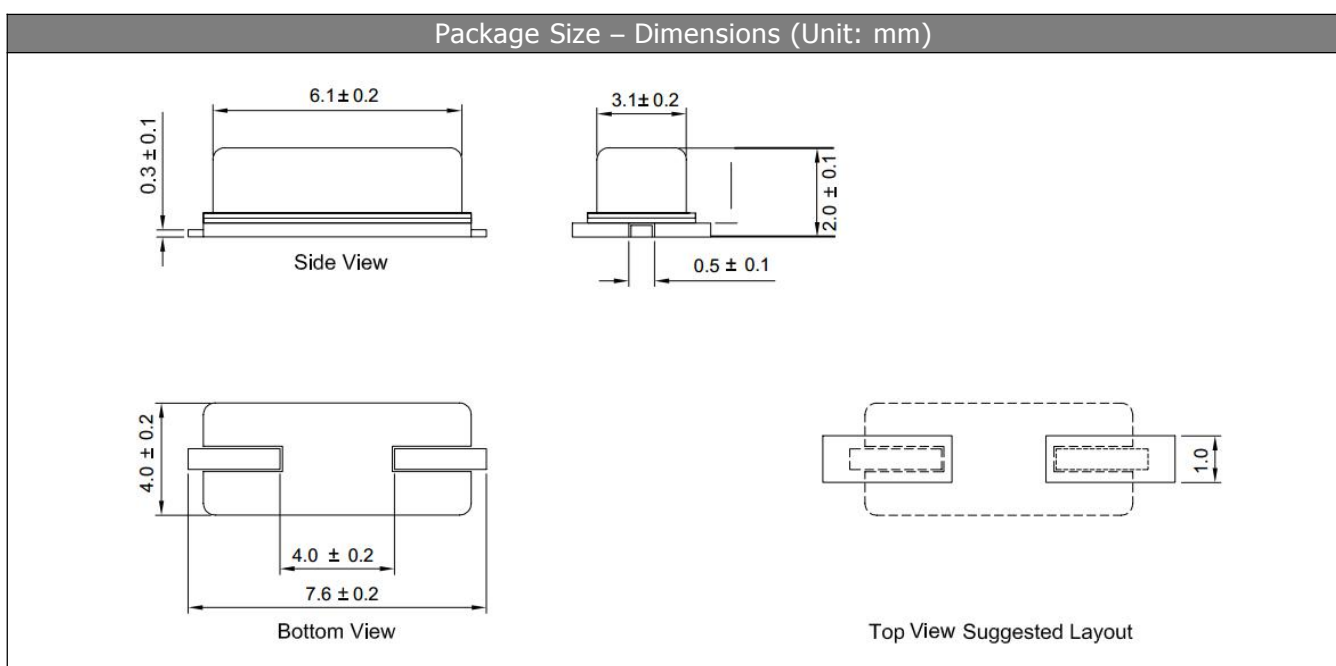

CRYSTAL UNIT

HC-49XSMD



Reflow Soldering Profile

Pre Heating Temperature
 Tp1 ~ Tp2 = + 170 °C
 Heating Temperature
 TMI = + 220 °C
 Peak Temperature
 TMax. = + 260 °C

Point of measuring
 In case of Solder ability Terminal.
 In case of Resistance to soldering heat Surface.

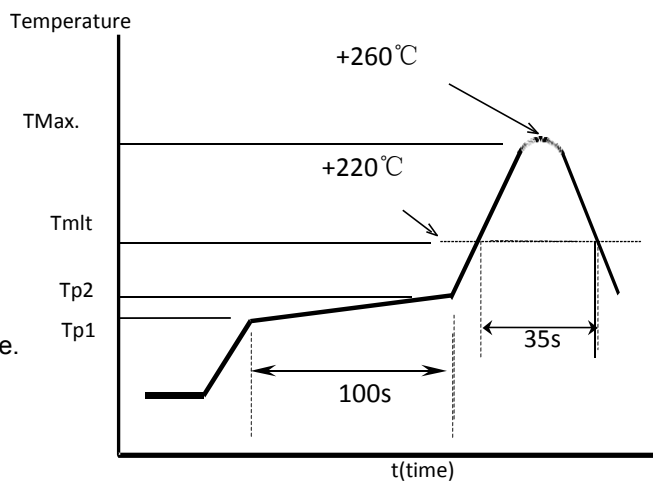

Taping Specification(Unit: mm)

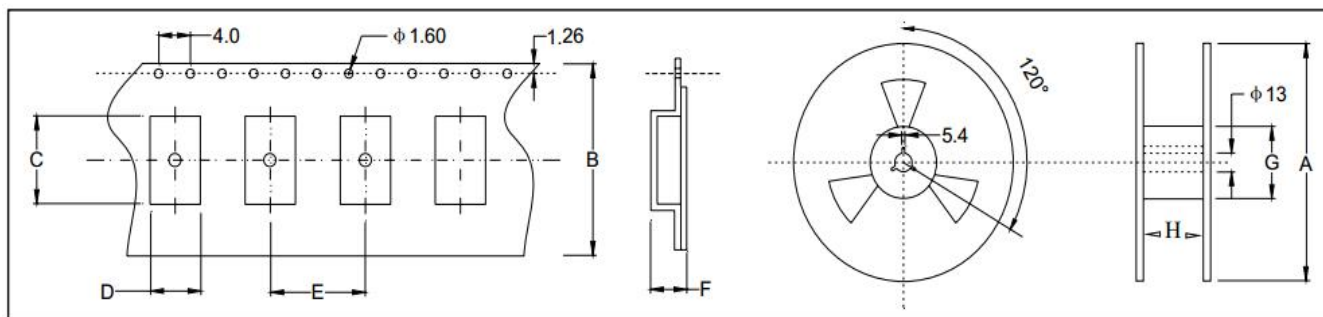

Size	A	B	C	D	E	F	G	H
49XSMD	330±2.0	16.0±0.3	9.50±0.1	4.70±0.1	8.0±0.1	2.35±0.1	100.0±1.0	17.5±1.0

3000 pcs per reel

单击下面可查看定价，库存，交付和生命周期等信息

[>>YXC\(扬兴\)](#)