

## BT152-650R

### MAIN FEATURES

Symbol	Value	Unit
$I_{T(RMS)}$	12	A
$V_{DRM}/V_{RRM}$	650R	V

### DESCRIPTION:

With high ability to withstand the shock loading of large current, BT152-650R of silicon controlled rectifiers provides high  $dV/dt$  rate with strong resistance to electromagnetic interference. It is especially recommended for use on solid state relay, motorcycle, power charger, T-tools etc. From all three terminals to external heatsink.

Package TO-220AB is RoHS compliant.

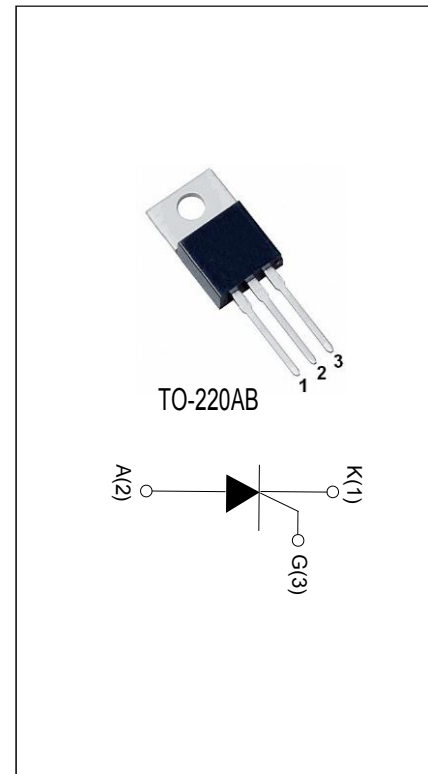

### ABSOLUTE MAXIMUM RATINGS

Parameter	Symbol	Value	Unit
Storage junction temperature range	$T_{stg}$	-40-150	$^{\circ}C$
Operating junction temperature range	$T_j$	-40-125	$^{\circ}C$
Repetitive peak off-state voltage ( $T_j=25^{\circ}C$ )	$V_{DRM}$	650	V
Repetitive peak reverse voltage ( $T_j=25^{\circ}C$ )	$V_{RRM}$	650	V
RMS on-state current ( $T_c \leq 80^{\circ}C$ )	$I_{T(RMS)}$	12	A
Non repetitive surge peak on-state current (full cycle, $t_p=20ms$ , $T_j=25^{\circ}C$ )	$I_{TSM}$	120	A
$I^2t$ value for fusing ( $t_p=10ms$ , $T_j=25^{\circ}C$ )	$I^2t$	144	$A^2s$
Critical rate of rise of on-state current ( $T_j=125^{\circ}C$ )	$di/dt$	50	$A/\mu s$
Peak gate current ( $t_p=20\mu s$ , $T_j=125^{\circ}C$ )	$I_{GM}$	4	A
Average gate power dissipation ( $T_j=125^{\circ}C$ )	$P_{G(AV)}$	1	W

**ELECTRICAL CHARACTERISTICS** ( $T_j=25^{\circ}\text{C}$  unless otherwise specified)

Symbol	Test Condition	Value		Unit
$I_{GT}$	$V_D = 12\text{V}$ $R_L = 100\Omega$	MAX.	15	mA
$V_{GT}$		MAX.	1.5	V
$V_{GD}$	$V_D = V_{DRM}$ $T_j = 125^{\circ}\text{C}$ $R_L = 100\Omega$	MIN.	0.2	V
$I_L$	$I_G = 1.2I_{GT}$	MAX.	40	mA
			60	
$I_H$	$I_T = 500\text{mA}$	MAX.	30	mA
$dV/dt$	$V_D = 2/3V_{DRM}$ $T_j = 125^{\circ}\text{C}$	MIN.	500	V/ $\mu\text{s}$

**STATIC CHARACTERISTICS**

Symbol	Parameter		Value(MAX.)	Unit
$V_{TM}$	$I_{TM} = 32\text{A}$	$T_j = 25^{\circ}\text{C}$	1.5	V
$V_{TO}$	Threshold voltage	$T_j = 125^{\circ}\text{C}$	0.86	V
$R_D$	Dynamic resistance	$T_j = 125^{\circ}\text{C}$	36.6	$\text{m}\Omega$
$I_{DRM}$	$V_D = V_{DRM}$ $V_R = V_{RRM}$	$T_j = 25^{\circ}\text{C}$	5	$\mu\text{A}$
$I_{RRM}$		$T_j = 125^{\circ}\text{C}$	1	mA

**THERMAL RESISTANCES**

Symbol	Parameter	Value	Unit
$R_{th(j-c)}$	junction to case (AC)	1.75	$^{\circ}\text{C}/\text{W}$

**ORDERING INFORMATION**

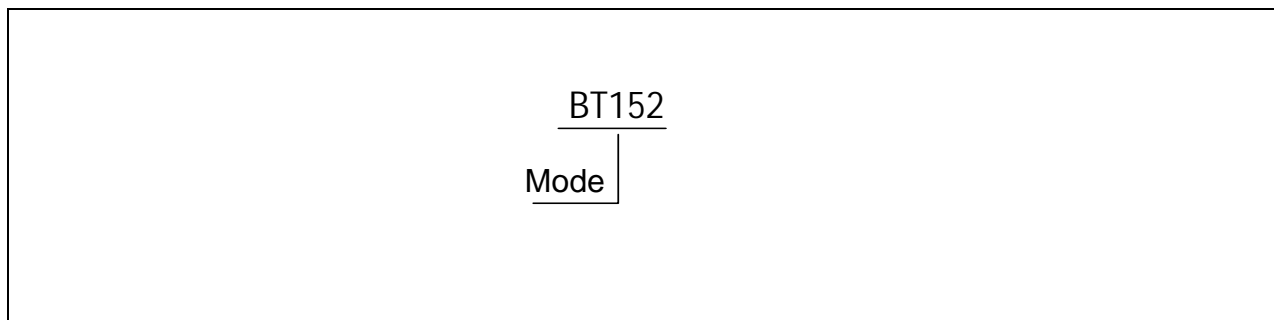

**MARKING**

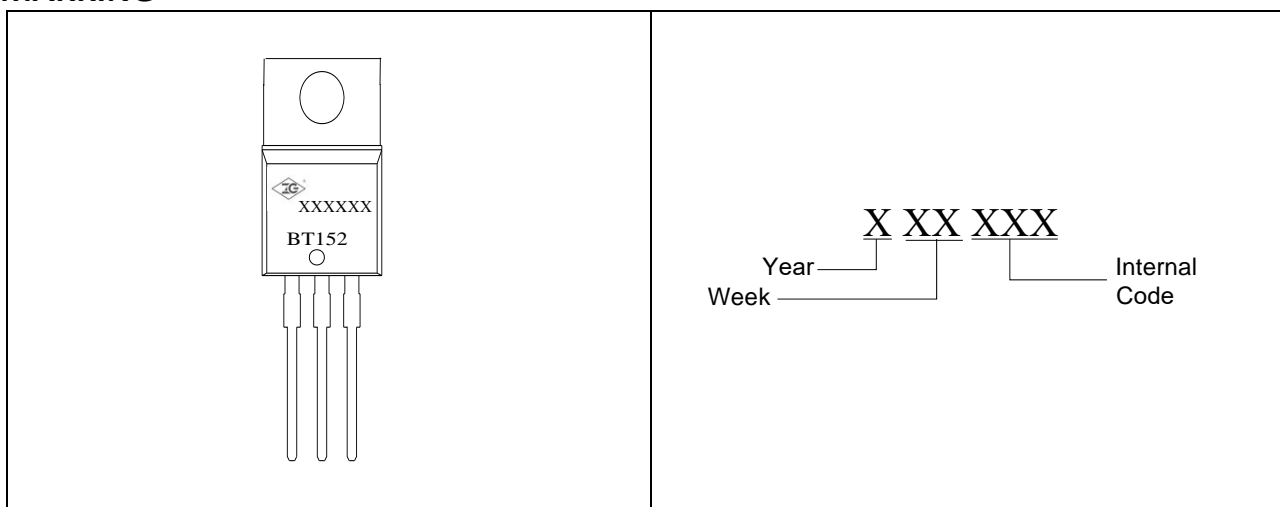

**ORDERING INFORMATION**

Order code	Voltage V <sub>DRM</sub> /V <sub>R<sub>RRM</sub></sub> (V)	Package	Base qty. (pcs)	Delivery mode
BT152-650R	650	TO-220AB	50	Tube

PACKAGE MECHANICAL DATA

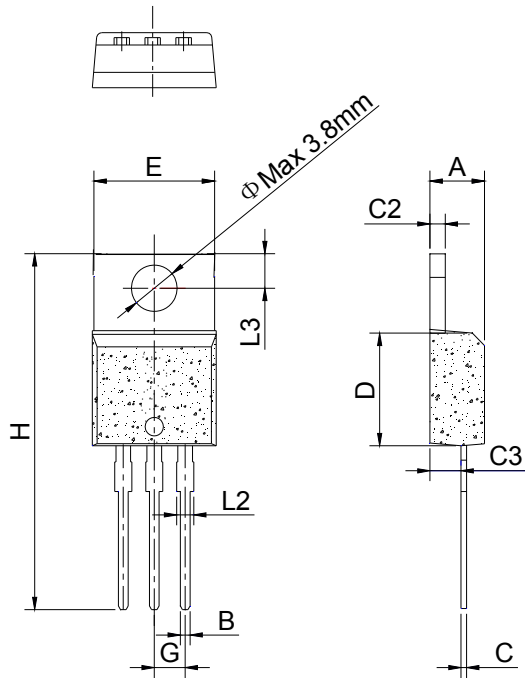

TO-220AB

Ref.	Dimensions		
	Millimeters		
	Min.	Typ.	Max.
A	4.30	4.50	4.70
B	0.60	0.80	1.00
C	0.28	0.38	0.48
C2	1.17	1.27	1.37
C3	2.30	2.50	2.70
D	8.80	9.00	9.20
E	9.80	10.00	10.20
G	2.44	2.54	2.64
H	28.55	28.85	29.15
L2	1.10	1.30	1.50
L3	2.59	2.74	2.89

DELIVERY MODE

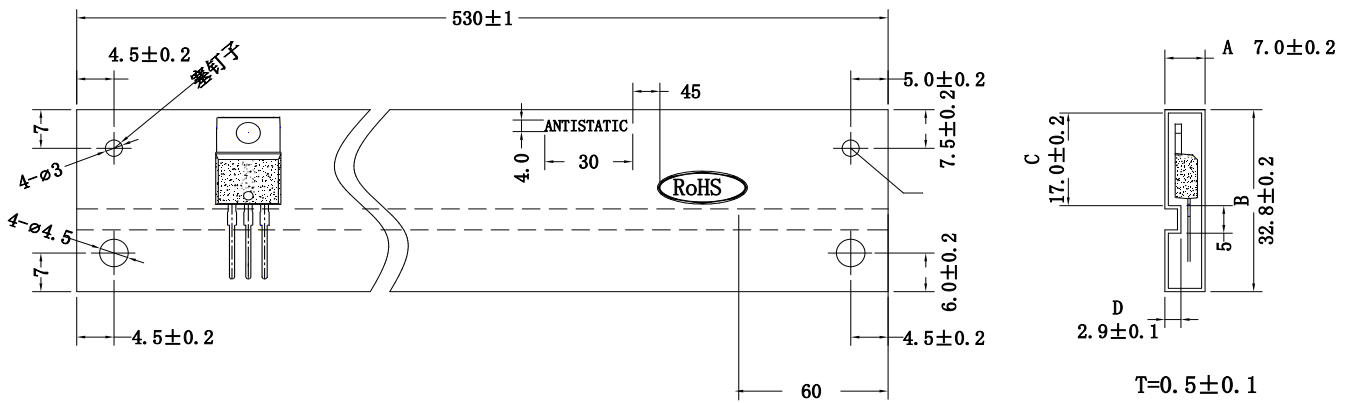

PACKAGE	OUTLINE	TUBE (PCS)	INNER BOX (PCS)	PER CARTON
TO-220AB	TUBE	50	1,000	5,000

**FIG.1** Maximum power dissipation versus RMS on-state current

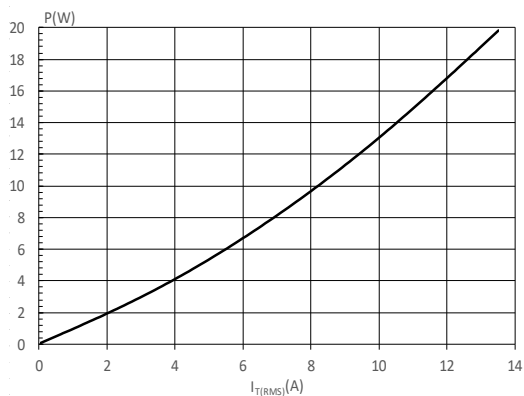

**FIG.2:** RMS on-state current versus case temperature

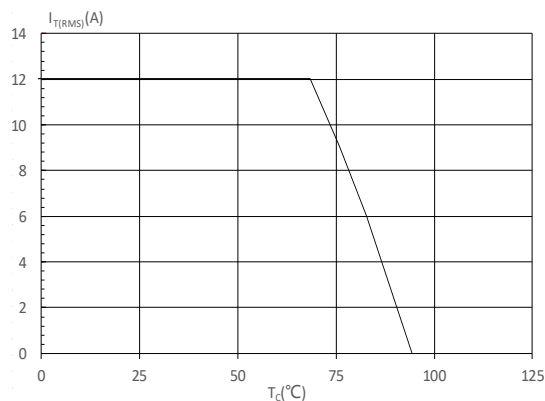

**FIG.3:** Surge peak on-state current versus number of cycles

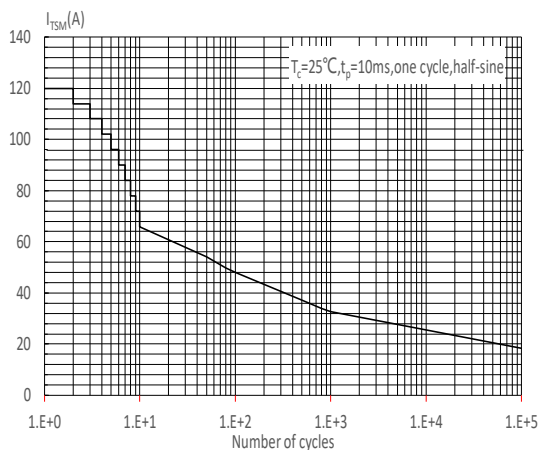

**FIG.5:** Non-repetitive surge peak on-state current for a sinusoidal pulse with width  $t_p < 10\text{ms}$ , and corresponding value of  $I^2t$  ( $di/dt < 100\text{A}/\mu\text{s}$ )

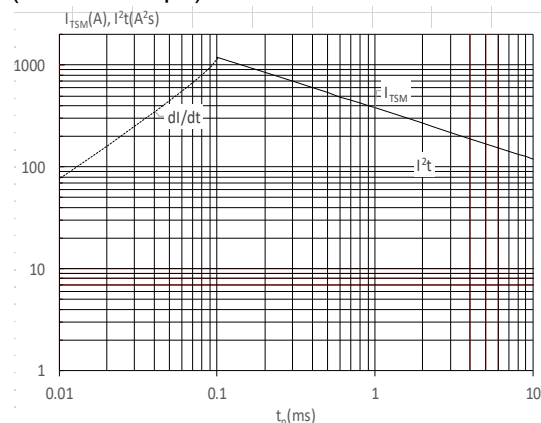

**FIG.4:** On-state characteristics

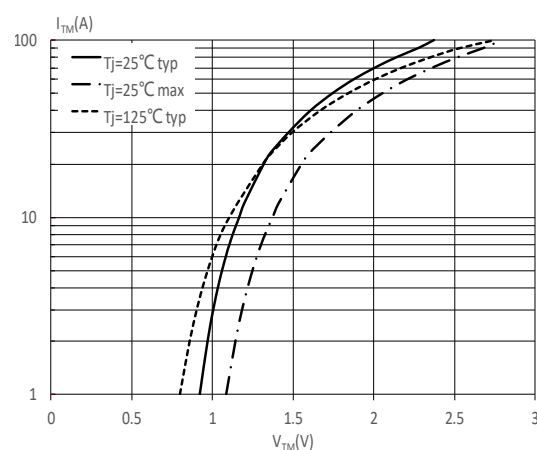

**FIG.6:** Relative variations of gate trigger current, holding current and latching current versus junction temperature

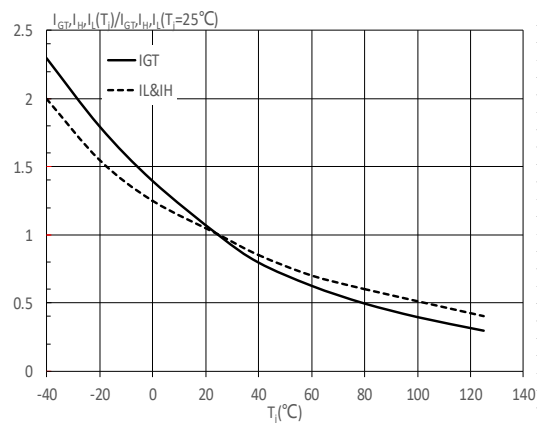

单击下面可查看定价，库存，交付和生命周期等信息

[>>ZG\(中鑫半导体\)](#)