

BT136-800E
MAIN FEATURES 4Q TRIAC

| Symbol | Value | Unit |
|-------------------|-------------|------|
| $I_{T(RMS)}$ | 4 | A |
| V_{DRM}/V_{RRM} | 800 | V |
| $I_{GT1/2/3}$ | 10/10/10/25 | mA |

DESCRIPTION:

The BT134-800E triac is suitable for general purpose AC switching. It can be used as an ON/OFF function in applications such as heating regulation, induction motor starting circuits, for phase control operation in light dimmers, motor speed controllers. From T2 terminals to external heatsink.

Package TO-220AB is RoHS compliant.

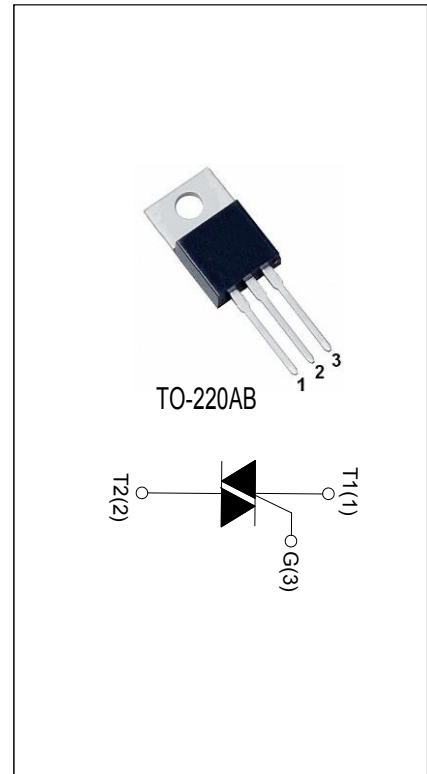
ABSOLUTE MAXIMUM RATINGS

| Parameter | Symbol | Value | Unit |
|---|--------------|---------|------------------------|
| Storage junction temperature range | T_{stg} | -40-150 | °C |
| Operating junction temperature range | T_j | -40-125 | °C |
| Repetitive peak off-state voltage ($T_j=25^\circ\text{C}$) | V_{DRM} | 800 | V |
| Repetitive peak reverse voltage ($T_j=25^\circ\text{C}$) | V_{RRM} | 800 | V |
| RMS on-state current ($T_c \leq 90^\circ\text{C}$) | $I_{T(RMS)}$ | 4 | A |
| Non repetitive surge peak on-state current (full cycle , $t_p=20\text{ms}$, $T_j=25^\circ\text{C}$) | I_{TSM} | 120 | A |
| I^2t value for fusing ($t_p=10\text{ms}$, $T_j=25^\circ\text{C}$) | I^2t | 72 | A^2s |
| Critical rate of rise of on-state current ($T_j=125^\circ\text{C}$) | di/dt | 50 | $\text{A}/\mu\text{s}$ |
| Peak gate current ($t_p=20\mu\text{s}$, $T_j=125^\circ\text{C}$) | I_{GM} | 4 | A |
| Average gate power dissipation ($T_j=125^\circ\text{C}$) | $P_{G(AV)}$ | 10 | W |

ELECTRICAL CHARACTERISTICS ($T_j=25^\circ\text{C}$ unless otherwise specified)

| Symbol | Test Condition | Quadrant | Value | | Unit |
|-------------|--|-------------|-------|------|------------------|
| I_{GT} | $V_D=12\text{V}$ $R_L=100\Omega$ | I - II -III | MAX. | 10 | mA |
| | | IV | | 25 | |
| V_{GT} | | ALL | MAX. | 1 | V |
| V_{GD} | $V_D=V_{DRM}$ $T_j=125^\circ\text{C}$ $R_L=100\Omega$ | ALL | MIN. | 0.2 | V |
| I_L | $I_G=1.2I_{GT}$ | I -III-IV | MAX. | 20 | mA |
| | | II | | 30 | |
| I_H | $I_T=500\text{mA}$ | | MAX. | 20 | mA |
| dV/dt | $V_D=2/3V_{DRM}$ $T_j=125^\circ\text{C}$ | | MIN. | 1000 | V/ μs |
| $(dI/dt)_c$ | $T_j=125^\circ\text{C}$ | | MIN. | 8 | A/ms |

STATIC CHARACTERISTICS

| Symbol | Parameter | | Value(MAX.) | Unit |
|-----------|-----------------------------|-------------------------|-------------|------------------|
| V_{TM} | $I_{TM}=32\text{A}$ | $T_j=25^\circ\text{C}$ | 1.40 | V |
| V_{TO} | Threshold voltage | $T_j=125^\circ\text{C}$ | 0.86 | V |
| R_D | Dynamic resistance | $T_j=125^\circ\text{C}$ | 36.6 | $\text{m}\Omega$ |
| I_{DRM} | $V_D=V_{DRM}$ $V_R=V_{RRM}$ | $T_j=25^\circ\text{C}$ | 5 | μA |
| I_{RRM} | | $T_j=125^\circ\text{C}$ | 1 | mA |

THERMAL RESISTANCES

| Symbol | Parameter | Value | Unit |
|---------------|-----------------------|-------|---------------------------|
| $R_{th(j-c)}$ | junction to case (AC) | 1.25 | $^\circ\text{C}/\text{W}$ |

ORDERING INFORMATION

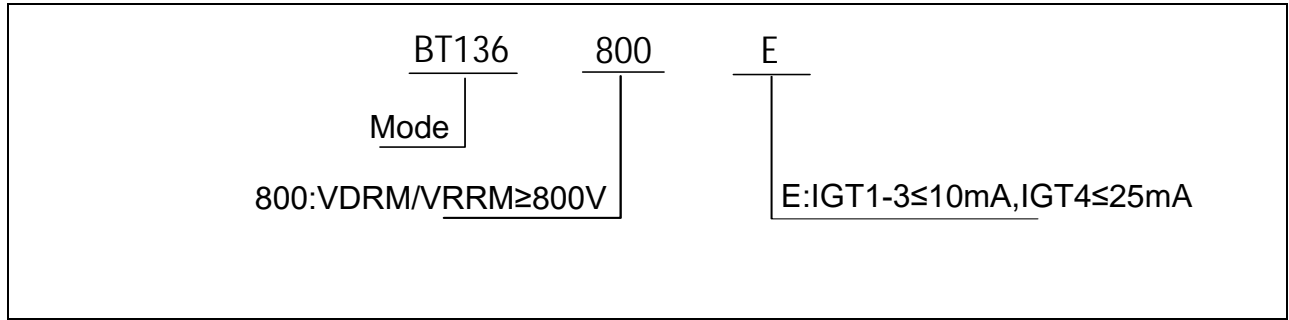

MARKING

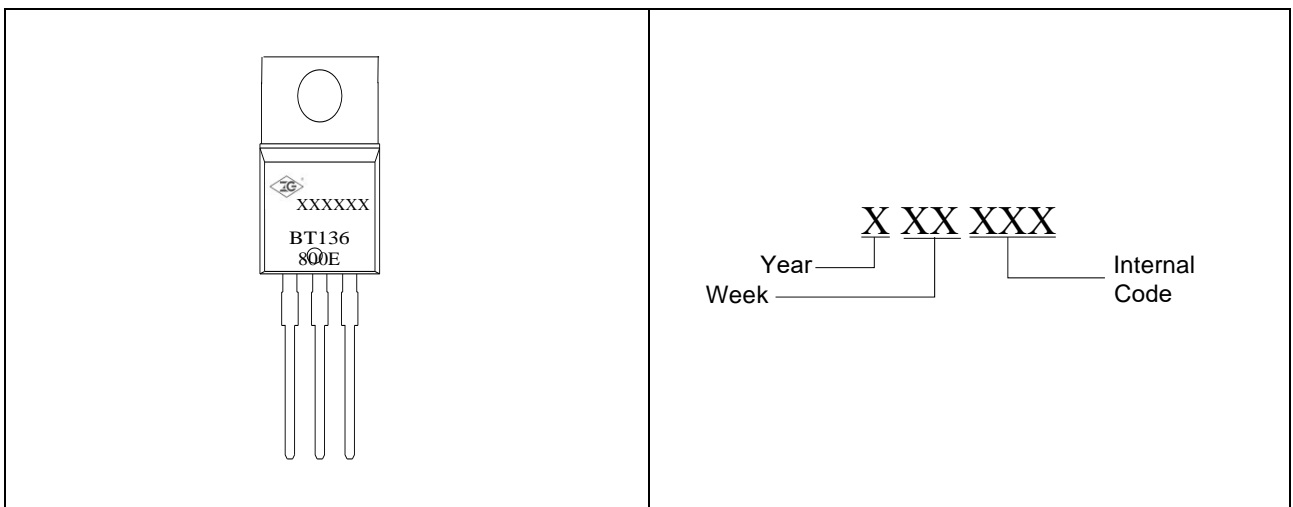

ORDERING INFORMATION

| Order code | Voltage V _{DRM} /V _{RRM} (V) | IGT(mA) | | Package | Base qty. (pcs) | Delivery mode |
|------------|---|--------------|----|----------|--------------------|---------------|
| | | I - II - III | IV | | | |
| BT136-800E | 800 | 10 | 25 | TO-220AB | 50 | Tube |

PACKAGE MECHANICAL DATA

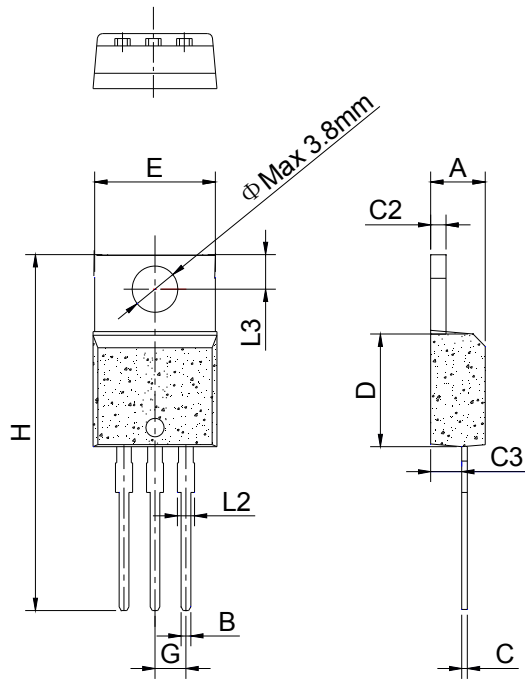

| Ref. | Dimensions | | |
|------|-------------|-------|-------|
| | Millimeters | | |
| | Min. | Typ. | Max. |
| A | 4.30 | 4.50 | 4.70 |
| B | 0.60 | 0.80 | 1.00 |
| C | 0.28 | 0.38 | 0.48 |
| C2 | 1.17 | 1.27 | 1.37 |
| C3 | 2.30 | 2.50 | 2.70 |
| D | 8.80 | 9.00 | 9.20 |
| E | 9.80 | 10.00 | 10.20 |
| G | 2.44 | 2.54 | 2.64 |
| H | 28.55 | 28.85 | 29.15 |
| L2 | 1.10 | 1.30 | 1.50 |
| L3 | 2.59 | 2.74 | 2.89 |

DELIVERY MODE

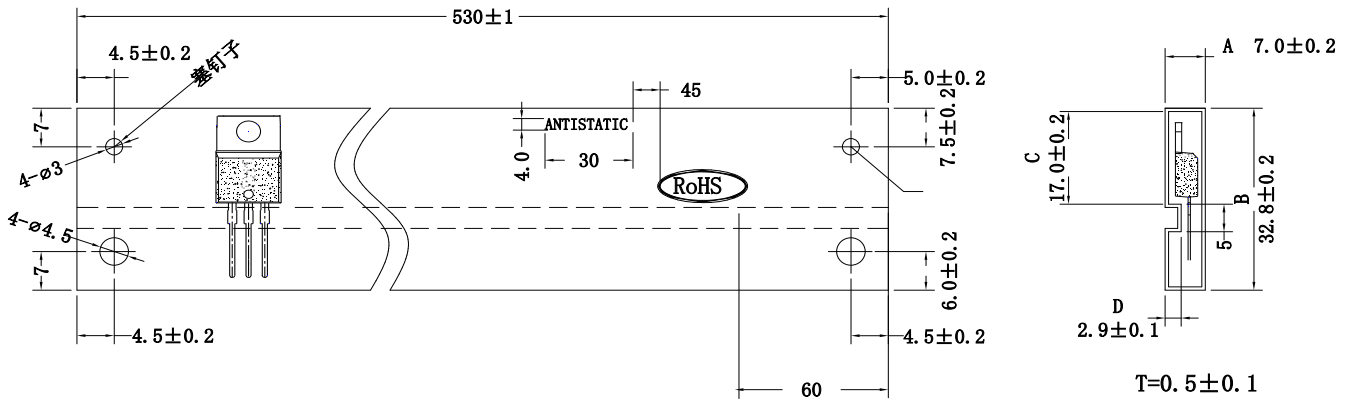

| PACKAGE | OUTLINE | TUBE (PCS) | INNER BOX (PCS) | PER CARTON |
|----------|---------|------------|-----------------|------------|
| TO-220AB | TUBE | 50 | 1,000 | 5,000 |

FIG.1 Maximum power dissipation versus RMS on-state current

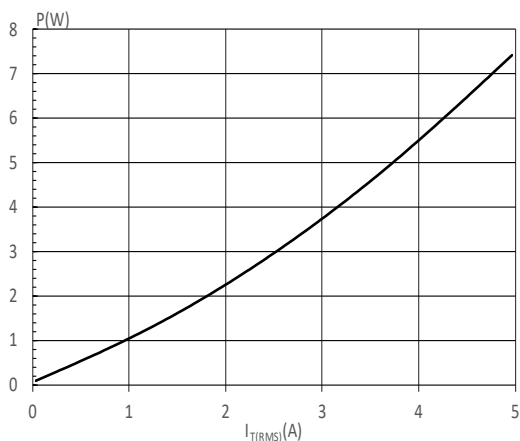

FIG.3: Surge peak on-state current versus number of cycles

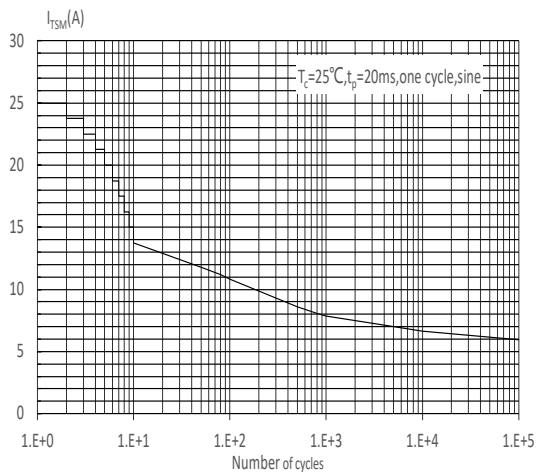

FIG.5: Non-repetitive surge peak on-state current for a sinusoidal pulse with width $t_p < 20\text{ms}$, and corresponding value of I^2t (I - II -III: $di/dt < 70\text{A}/\mu\text{s}$; IV: $di/dt < 40\text{A}/\mu\text{s}$)

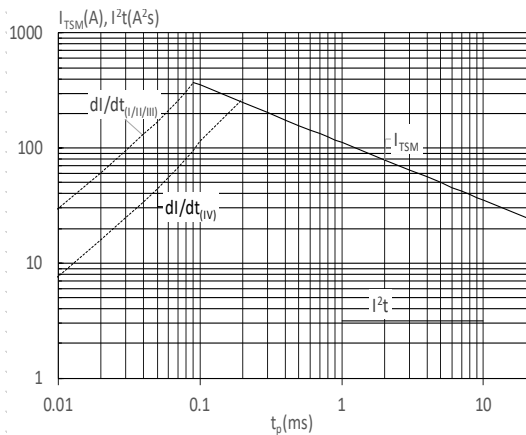

FIG.2: RMS on-state current versus case temperature

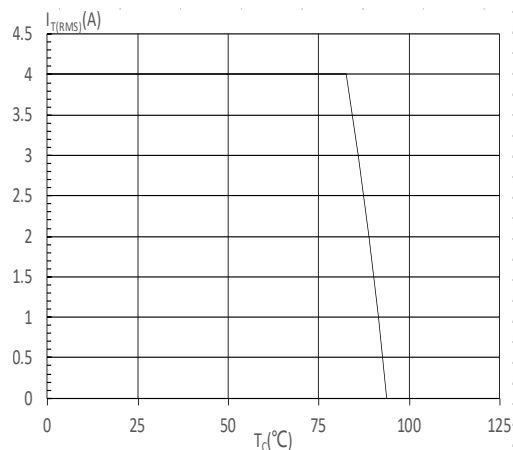

FIG.4: On-state characteristics

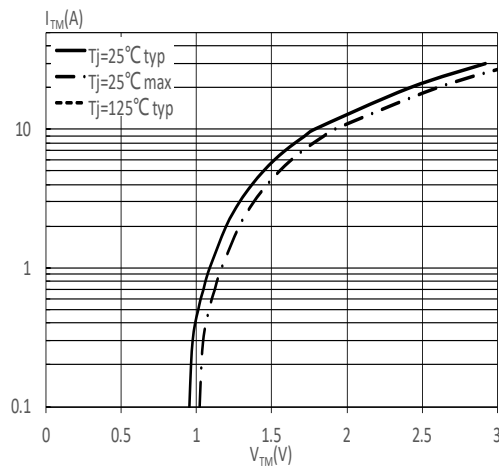
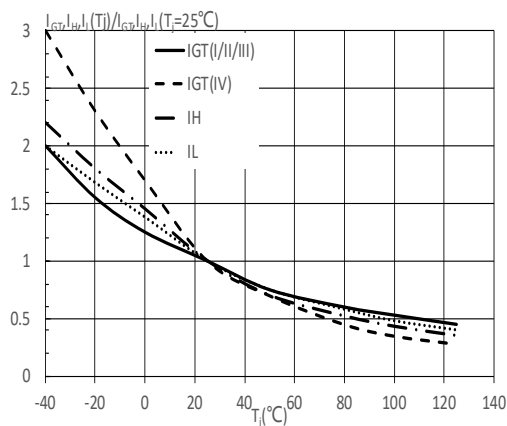

FIG.6: Relative variations of gate trigger current, holding current and latching current versus junction temperature



单击下面可查看定价，库存，交付和生命周期等信息

[>>ZG\(中鑫半导体\)](#)