



SF10A01 THRU SF10A06

SUPER FAST RECTIFIERS

Reverse Voltage - 100 to 600 Volts Forward Current - 10.0 Amperes

FEATURES

- Low cost.
- Low leakage.
- Low forward voltage drop.
- High current capability.
- Easily cleaned with Alcohol, Isopropanol and Similar solvents.
- The plastic material carries U/L recognition 94V-0

MECHANICAL DATA

- Case: TO-220AC
- Molding Compound: UL Flammability Classification Rating 94V-0
- Terminals: Matte tin-plated leads; solderability-per MIL-STD-202, Method 208

TO-220AC

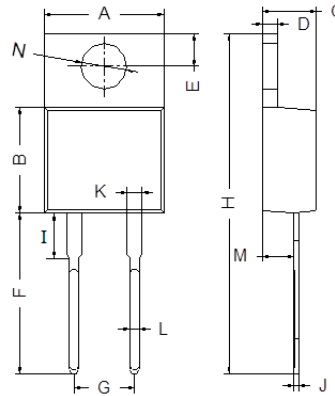

TO-220AC		
Dim	Min	Max
A	9.80	10.30
B	8.30	8.90
C	4.37	4.77
D	1.10	1.45
E	2.62	2.87
F	13.14	13.74
G	4.98	5.18
H	28.40	29.16
I	3.55	4.05
J	0.35	0.58
K	1.20	1.32
L	0.68	0.94
M	2.40	2.60
N	3.71	3.91
All Dimensions in mm		

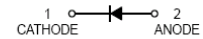
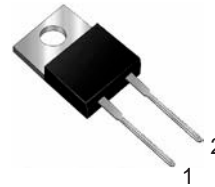

Maximum Ratings and Electrical Characteristics @T_A=25°C unless otherwise specified

Single Phase, half wave, 60Hz, resistive or inductive load.
For capacitive load, derate current by 20%.

Characteristic	Symbol	SF10 A01	SF10 A02	SF10 A03	SF10 A04	SF10 A05	SF10 A06	Unit
Peak Repetitive Reverse Voltage	V _{RRM}	100	200	300	400	500	600	V
Working Peak Reverse Voltage	V _{RWM}							
DC Blocking Voltage	V _R							
RMS Reverse Voltage	V _{R(RMS)}	70	140	210	280	350	420	V
Average Rectified Output Current @T _C = 100°C	I _(AV)	10.0						A
Non-Repetitive Peak Forward Surge Current 8.3ms Single half sine-wave superimposed on rated load (JEDEC Method)	I _{FSM}	100						A
Forward Voltage @I _F = 10.0A	V _F	1.0		1.3		1.7		V
Peak Reverse Current @T _A = 25°C	I _{RM}	10.0						μA
At Rated DC Blocking Voltage @T _A = 100°C		250						
Reverse Recovery Time (Note 1)	t _{rr}	35						nS
Typical Junction Capacitance (Note 2)	C _j	65						pF
Operating and Storage Temperature Range	T _i , T _{STG}	-55 to +150						°C

Note: 1. Measured with I_F = 0.5A, I_R = 1.0A, I_{RR} = 0.25A.
2. Measured at 1.0 MHz and applied reverse voltage of 4.0V D.C.



Ratings and Characteristics Curves (@ $T_A = 25^\circ\text{C}$ unless otherwise specified)

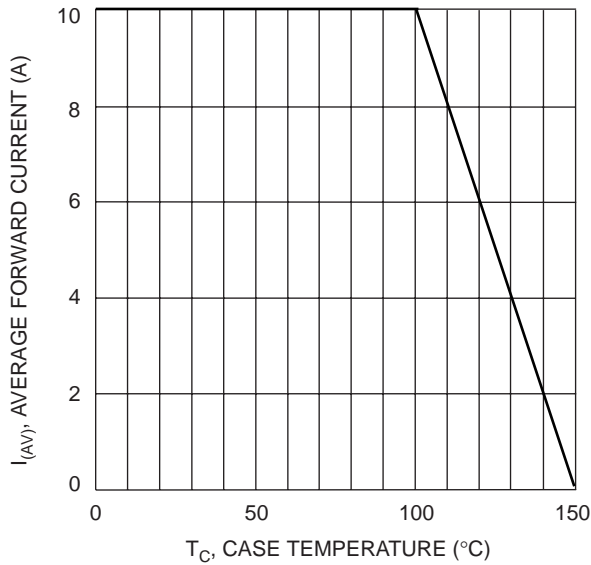

Fig. 1 Forward Current Derating Curve

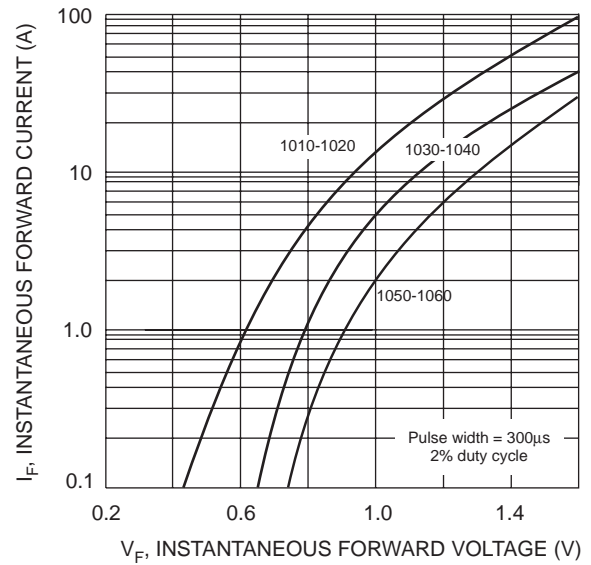

Fig. 2 Typical Forward Characteristics

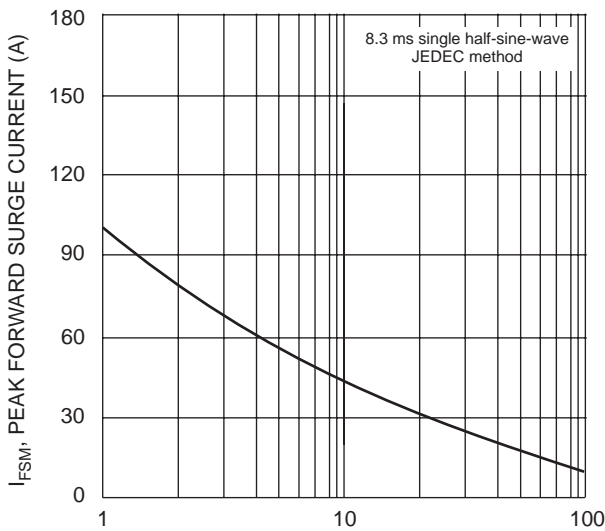

Fig. 3 Max Non-Repetitive Surge Current

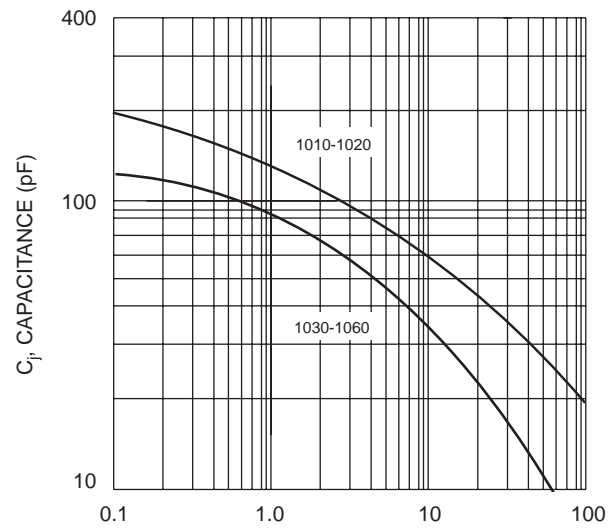
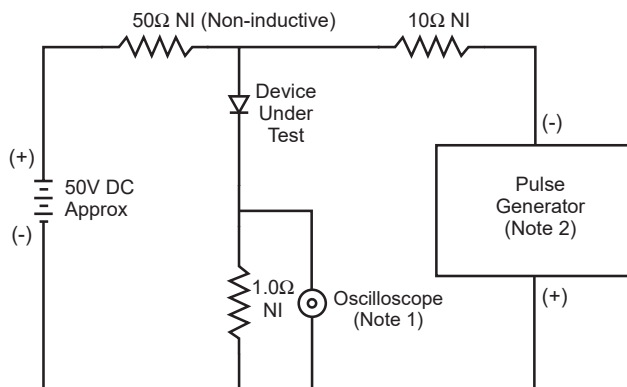

Fig. 4 Typical Junction Capacitance



Notes:

1. Rise Time = 7.0ns max. Input Impedance = 1.0MΩ, 22pF.
2. Rise Time = 10ns max. Input Impedance = 50Ω.

Fig. 5 Reverse Recovery Time Characteristic and Test Circuit

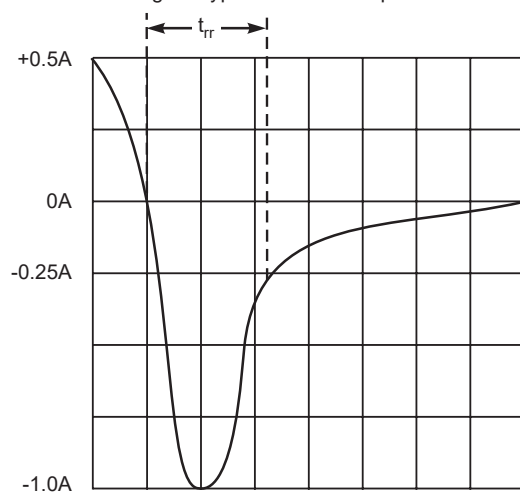

Set time base for 5/10ns/cm

单击下面可查看定价，库存，交付和生命周期等信息

[>>ZG\(中鑫半导体\)](#)