

**• General Description**

The ZM160P03D combines advanced trench MOSFET technology with a low resistance package to provide extremely low  $R_{DS(ON)}$ . This device is ideal for load switch and battery protection applications.

**• Features**

- Advance high cell density Trench technology
- Low  $R_{DS(ON)}$  to minimize conductive loss
- Low Gate Charge for fast switching
- Low Thermal resistance

**• Application**

- MB/VGA Vcore
- SMPS 2<sup>nd</sup> Synchronous Rectifier
- POL application
- BLDC Motor driver

**• Product Summary**

$V_{DS} = -30V$

$R_{DS(ON)} = 16m\Omega$

$I_D = -35A$

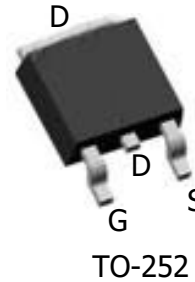
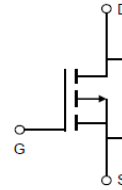
**• Ordering Information:**

Part NO.	ZM160P03D
Marking	ZM160P03
Packing Information	REEL TAPE
Basic ordering unit (pcs)	2500

**• Absolute Maximum Ratings ( $T_c = 25^\circ C$ )**

Parameter	Symbol	Rating	Unit
Drain-Source Voltage	$V_{DS}$	-30	V
Gate-Source Voltage	$V_{GS}$	$\pm 20$	V
Continuous Drain Current	$I_D @ TC=25^\circ C$	-35	A
	$I_D @ TC=75^\circ C$	-26	A
	$I_D @ TC=100^\circ C$	-22	A
Pulsed Drain Current <sup>①</sup>	$I_{DM}$	-70	A
Total Power Dissipation( $TC=25^\circ C$ )	$P_D @ TC=25^\circ C$	55	W
Total Power Dissipation( $TA=25^\circ C$ )	$P_D @ TA=25^\circ C$	2.5	W
Operating Junction Temperature	$T_J$	-55 to 150	$^\circ C$
Storage Temperature	$T_{STG}$	-55 to 150	$^\circ C$
Single Pulse Avalanche Energy	$E_{AS}$	160	mJ

**•Thermal resistance**

Parameter	Symbol	Min.	Typ.	Max.	Unit
Thermal resistance, junction - case	$R_{thJC}$	-	-	2.1	$^{\circ}C/W$
Thermal resistance, junction - ambient	$R_{thJA}$	-	-	50	$^{\circ}C/W$
Soldering temperature, wavesoldering for 10s	$T_{sold}$	-	-	265	$^{\circ}C$

**•Electronic Characteristics**

Parameter	Symbol	Condition	Min.	Typ	Max.	Unit
Drain-Source Breakdown Voltage	$BV_{DSS}$	$V_{GS}=0V, I_D=-250\mu A$	-30			V
Gate Threshold Voltage	$V_{GS(TH)}$	$V_{GS}=V_{DS}, I_D=-250\mu A$	-1.2	-1.7	-2.5	V
Drain-Source Leakage Current	$I_{DSS}$	$V_{DS}=-30V, V_{GS}=0V$			-1.0	$\mu A$
Gate- Source Leakage Current	$I_{GSS}$	$V_{GS}=\pm 20V, V_{DS}=0V$			$\pm 100$	nA
Static Drain-source On Resistance	$R_{DS(ON)}$	$V_{GS}=-10V, I_D=-20A$		16	21	m $\Omega$
		$V_{GS}=-4.5V, I_D=-10A$		26	35	m $\Omega$
Forward Transconductance	$g_{FS}$	$V_{DS}=-10V, I_D=-5A$		6		S
Source-drain voltage	VSD	$I_S=-20A$			1.28	V

**•Electronic Characteristics**

Parameter	Symbol	Condition	Min.	Typ	Max.	Unit
Input capacitance	$C_{iss}$	$f = 1MHz$	-	1450	-	pF
Output capacitance	$C_{oss}$		-	172	-	
Reverse transfer capacitance	$C_{rss}$		-	124	-	

**•Switching Parameter( $T_a = 25^{\circ}C$ )**

Parameter	Symbol	Condition	Min.	Typ	Max.	Unit	
Total gate charge	$Q_g$	$V_{DD}=-25V$	-	14	-	nC	
Gate - Source charge	$Q_{gs}$	$I_D=-15A$	-	6	-		
Gate - Drain charge	$Q_{gd}$	$V_{GS}=-10V$	-	5	-		
Turn-on Delay time	$t_{D(on)}$	$V_{GS}=-10V, V_{DS}=-15V, R_L=1.8\Omega, R_{GEN}=3\Omega$		8.8		ns	
Turn-on Rise time	$t_r$			8.6		ns	
Turn-off Delay time	$t_{D(off)}$				18.5		ns
Turn-off Fall time	$t_f$				7.3		ns

Body Diode Reverse Recovery Time	trr	$I_F = -8A,$ $dI/dt = 500A/us$	12.3	ns
Body Diode Reverse Recovery Charge	Qrr	$I_F = -8A,$ $dI/dt = 500A/us$	26.5	nC

Note: ① Pulse Test : Pulse width  $\leq 300\mu s$ , Duty cycle  $\leq 2\%$  ;

② Device mounted on FR-4 substrate PC board, 2oz copper, with thermal bias to bottom layer 1inch square copper plate;

Fig.1 Power Dissipation Derating Curve

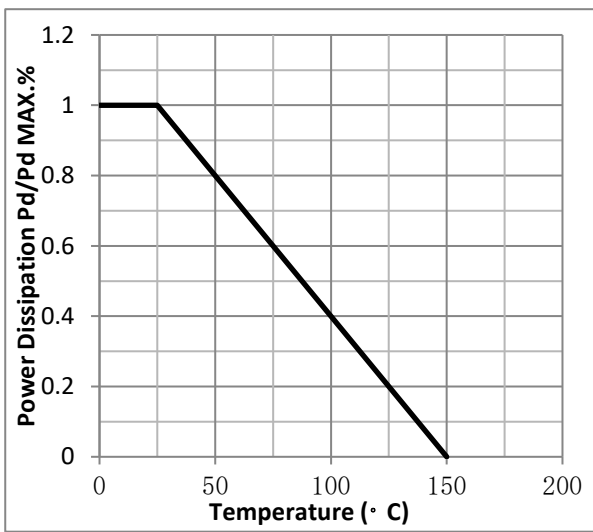

Fig.2 Typical output Characteristics

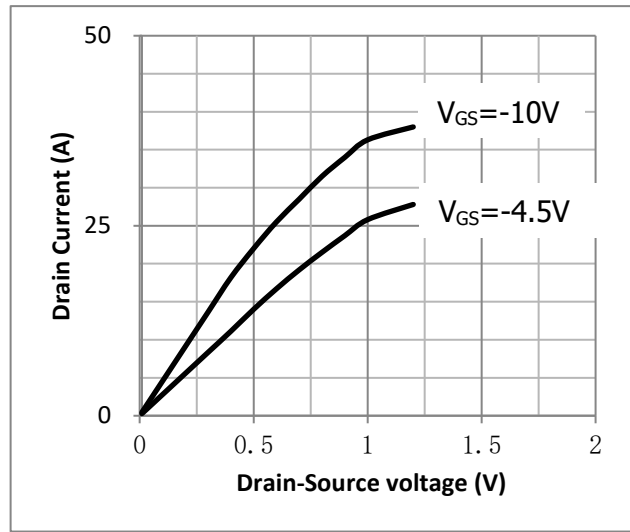

Fig.3 Threshold Voltage V.S Junction Temperature

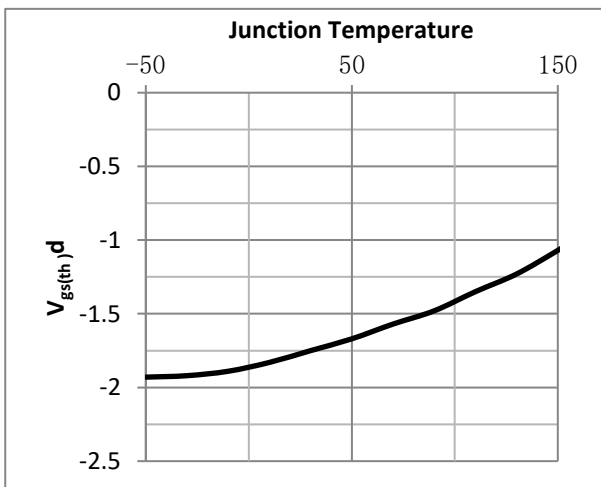

Fig.4 Resistance V.S Drain Current

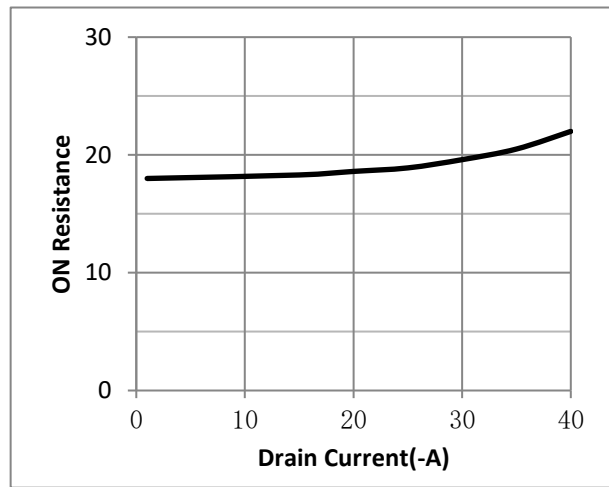

Fig.5 On-Resistance VS Gate Source Voltage

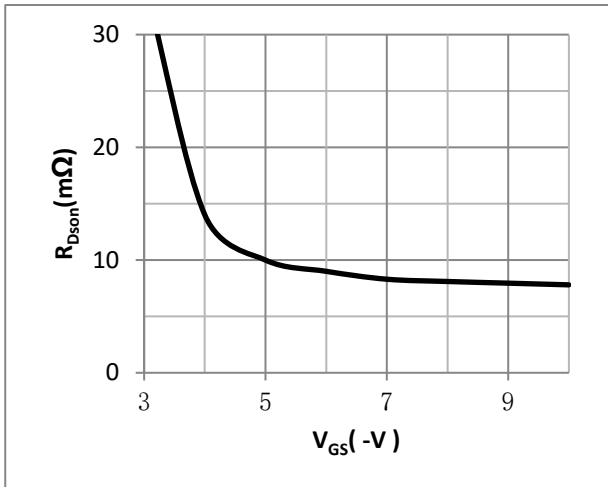

Fig.6 On-Resistance V.S Junction Temperature

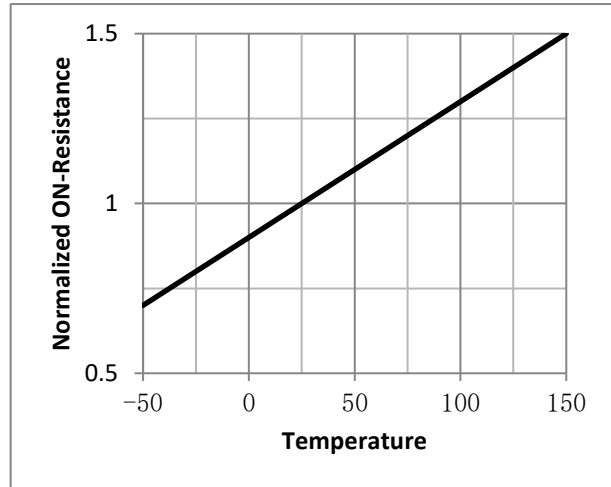

Fig.7 Switching Time Measurement Circuit

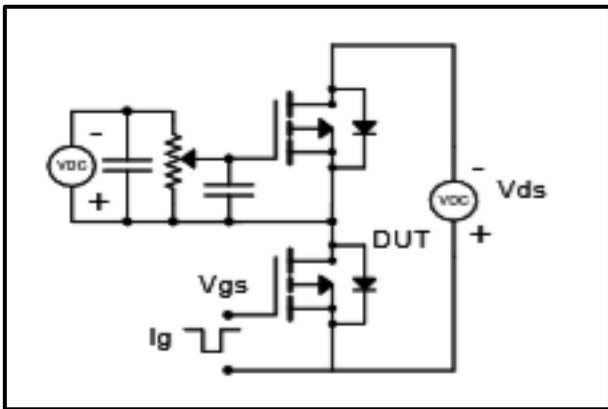

Fig.8 Gate Charge Waveform

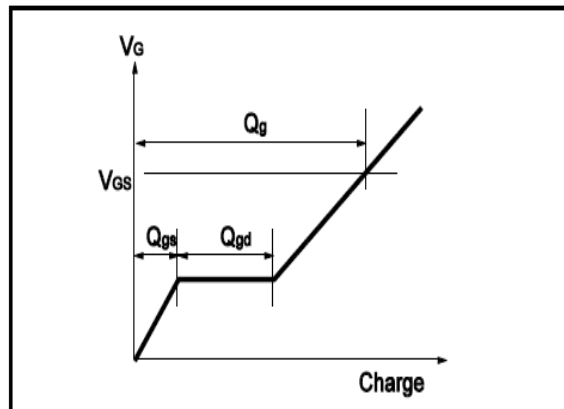

Fig.9 Switching Time Measurement Circuit

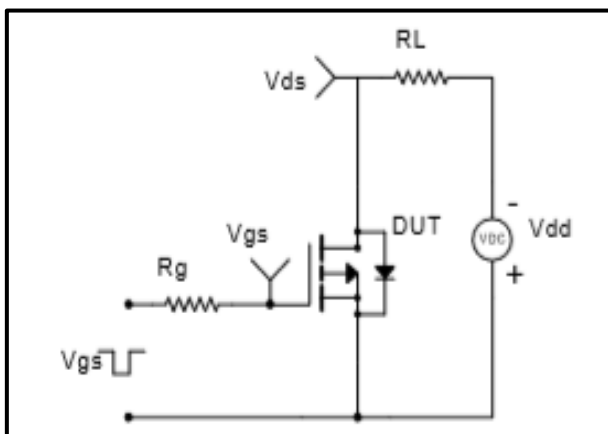

Fig.10 Gate Charge Waveform

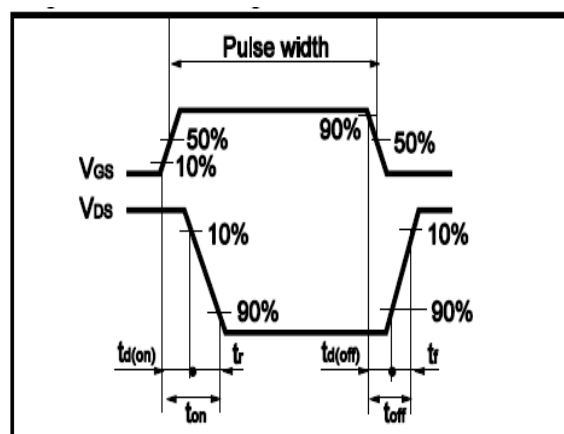

Fig.11 Avalanche Measurement Circuit

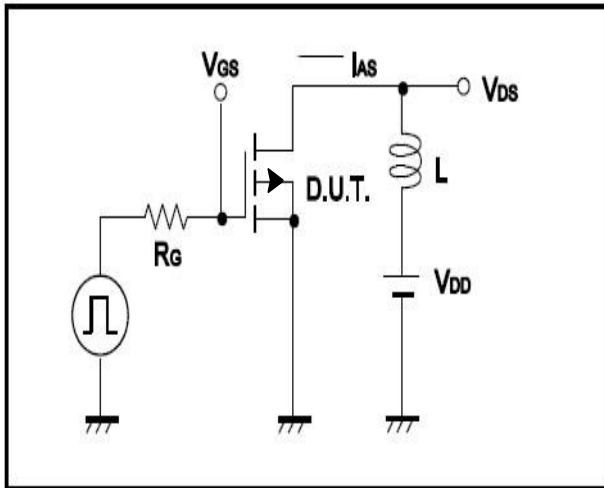
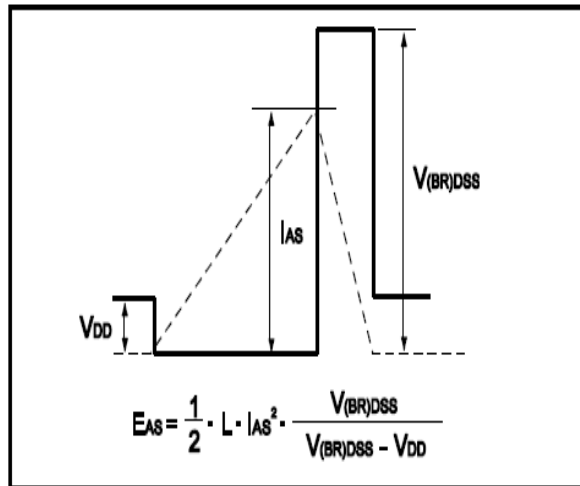

Fig.12 Avalanche Waveform



• Dimensions (TO-252)

Unit: mm

SYMBOL	min	max	SYMBOL	min	max
A	2.10	2.50	B	0.85	1.25
b	0.50	0.80	b1	0.50	0.90
b2	0.45	0.70	C	0.45	0.70
D	6.30	6.75	D1	5.10	5.50
E	5.30	6.30	e1	2.25	2.35
L1	9.20	10.60	e2	4.45	4.75
L2	0.90	1.75	L3	0.60	1.10
K	0.00	0.23			

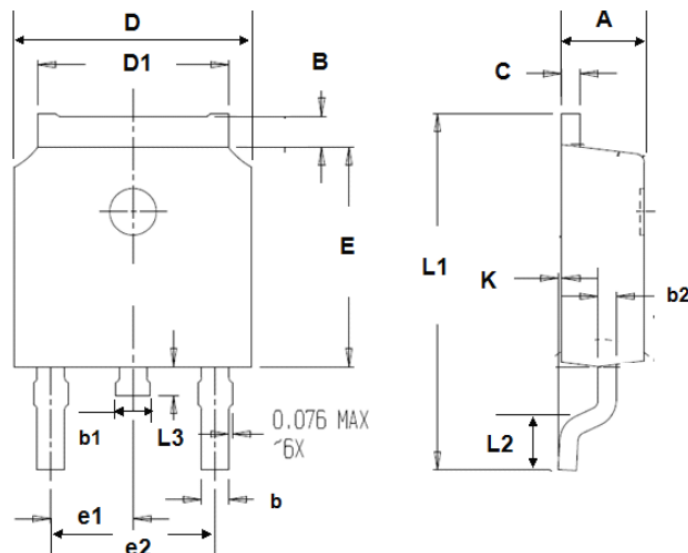

单击下面可查看定价，库存，交付和生命周期等信息

[>>ZMJSEMI\(真茂佳\)](#)