

• General Description

The ZMD68310M combines advanced trench MOSFET technology with a low resistance package to provide extremely low $R_{DS(ON)}$. Two N Channel MOSFET inside for dual DIE implication.

• Features

- Advance high cell density Trench technology
- Low $R_{DS(ON)}$ to minimize conductive loss
- Low Gate Charge for fast switching
- Dual DIE in one package

• Application

- Power Management in Notebook Computer
- BLDC Motor driver

• Ordering Information:

Part NO.	ZMD68310M
Marking	68310
Packing Information	REEL TAPE
Basic ordering unit (pcs)	5000

Absolute Maximum Ratings (T_C =25°C)

Parameter	Symbol	Rating	Unit
Drain-Source Voltage	V_{DS}	30	V
Gate-Source Voltage	V_{GS}	±20	V
Continuous Drain Current	$I_{D@TC=25^{\circ}C}$	12	A
	$I_{D@TC=75^{\circ}C}$	9	A
	$I_{D@TC=100^{\circ}C}$	7.5	A
Pulsed Drain Current ①	I_{DM}	36	A
Total Power Dissipation(TC=25°C)	$P_D@TC=25^{\circ}C$	3.2	W
Total Power Dissipation(TA=25°C)	$P_D@TA=25^{\circ}C$	0.65	W
Operating Junction Temperature	T_J	-55 to 150	°C
Storage Temperature	T_{STG}	-55 to 150	°C
Single Pulse Avalanche Energy	E_{AS}	65	mJ

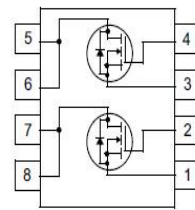
• Product Summary

$V_{DS1} = 30V$
 $V_{DS2} = 30V$
 $R_{DS(ON)1} = 10m\Omega$
 $R_{DS(ON)2} = 10m\Omega$
 $I_{D1} = 12A$
 $I_{D2} = 12A$

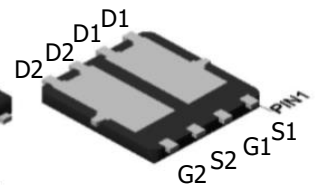
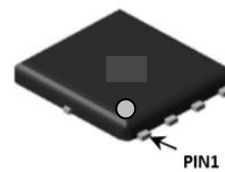

DFN3*3

•Thermal resistance

Parameter	Symbol	Min.	Typ.	Max.	Unit
Thermal resistance, junction - case	R_{thJC}	-	-	39	$^{\circ}C/W$
Thermal resistance, junction - ambient	R_{thJA}	-	-	190	$^{\circ}C/W$
Soldering temperature, wavesoldering for 10s	T_{sold}	-	-	265	$^{\circ}C$

Electronic Characteristics

Parameter	Symbol	Condition	Min.	Typ	Max.	Unit
Drain-Source Breakdown Voltage	BV_{DSS}	$V_{GS}=0V, I_D=250\mu A$	30			V
Gate Threshold Voltage	$V_{GS(TH)}$	$V_{GS}=V_{DS}, I_D=250\mu A$	1.2		2.5	V
Drain-Source Leakage Current	I_{DSS}	$V_{DS}=30V, V_{GS}=0V$			1.0	μA
Gate- Source Leakage Current	I_{GSS}	$V_{GS}=\pm 20V, V_{DS}=0V$			± 100	nA
Static Drain-source On Resistance	$R_{DS(ON)}$	$V_{GS}=10V, I_D=10A$		10	16	$m\Omega$
		$V_{GS}=4.5V, I_D=8A$		20	26	$m\Omega$
Forward Transconductance	g_{FS}	$V_{DS}=10V, I_D=5A$		4		S
Source-drain voltage	V_{SD}	$I_S=10A$			1.28	V

•Electronic Characteristics

Parameter	Symbol	Condition	Min.	Typ	Max.	Unit
Input capacitance	C_{iss}	$f = 1MHz$	-	850	-	pF
Output capacitance	C_{oss}		-	190	-	
Reverse transfer capacitance	C_{rss}		-	100	-	

•Gate Charge characteristics($T_a = 25^{\circ}C$)

Parameter	Symbol	Condition	Min.	Typ	Max.	Unit
Total gate charge	Q_g	$V_{DD}=25V$	-	10	-	nC
Gate - Source charge	Q_{gs}	$I_D=8A$	-	3.5	-	
Gate - Drain charge	Q_{gd}	$V_{GS}=10V$	-	5	-	
Body Diode Reverse Recovery Time	t_{rr}	$I_F=20A,$ $di/dt=100A/\mu s$		6.5		nS
Body Diode Reverse Recovery Charge	Q_{rr}	$I_F=20A,$ $di/dt=100A/\mu s$		7		nC

•N Channel characteristics curve

Fig.1 Power Dissipation Derating Curve

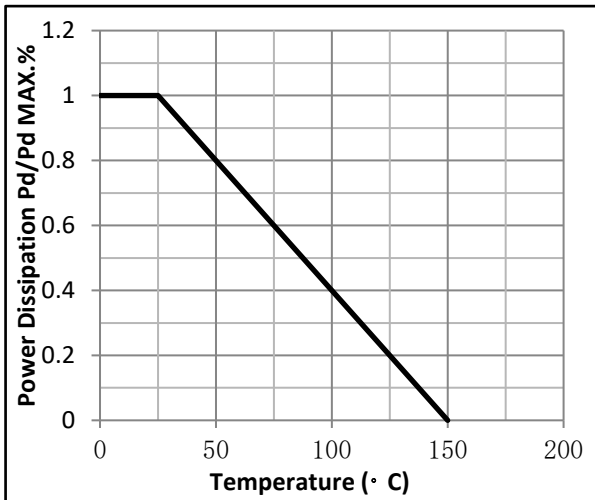

Fig.2 Typical output Characteristics

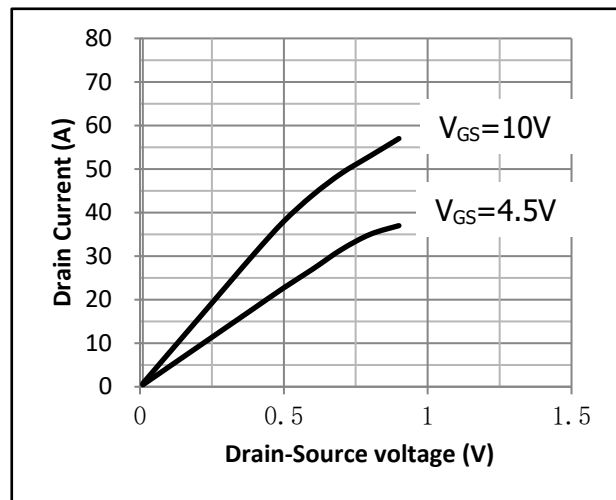

Fig.3 Threshold Voltage V.S Junction Temperature

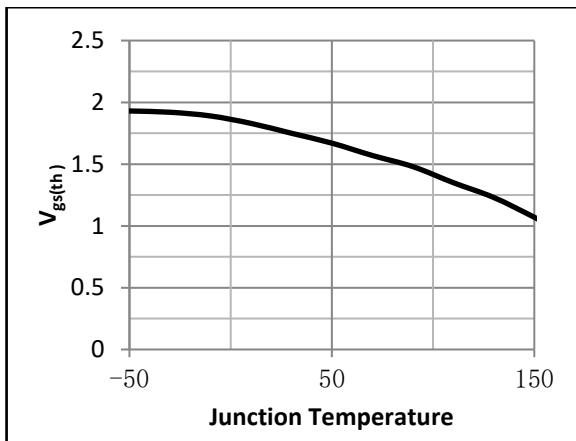

Fig.4 Resistance V.S Drain Current

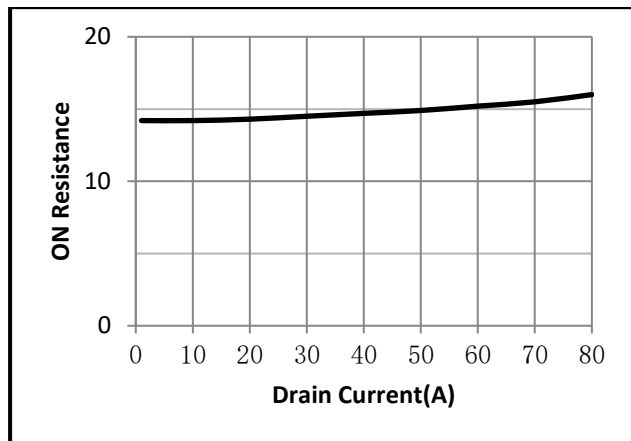

Fig.5 On-Resistance VS Gate Source Voltage

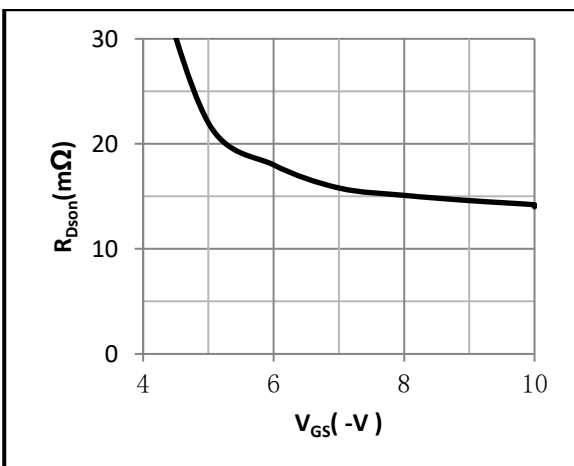
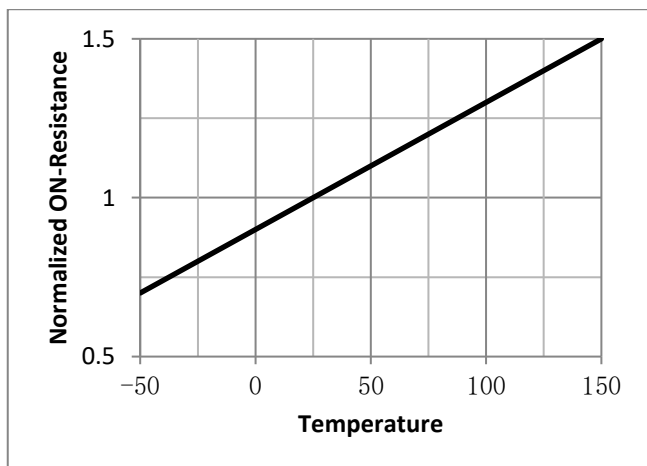

Fig.6 On-Resistance V.S Junction Temperature



•Test Circuit

Fig.1 Switching Time Measurement Circuit

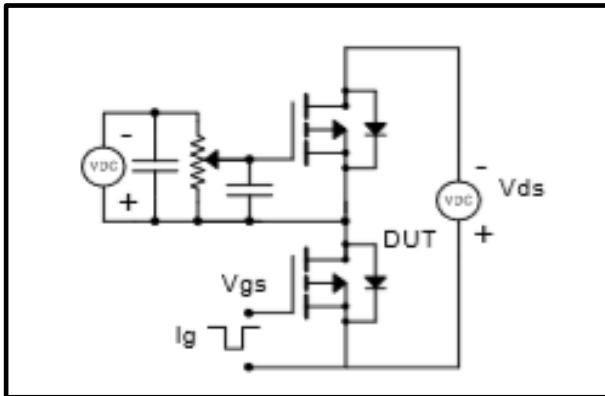

Fig.2 Gate Charge Waveform

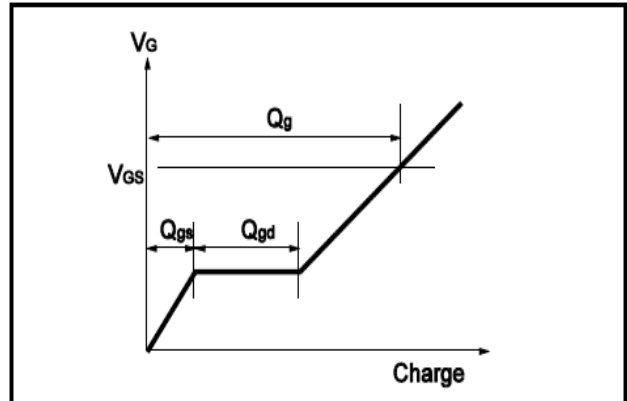

Fig.3 Switching Time Measurement Circuit

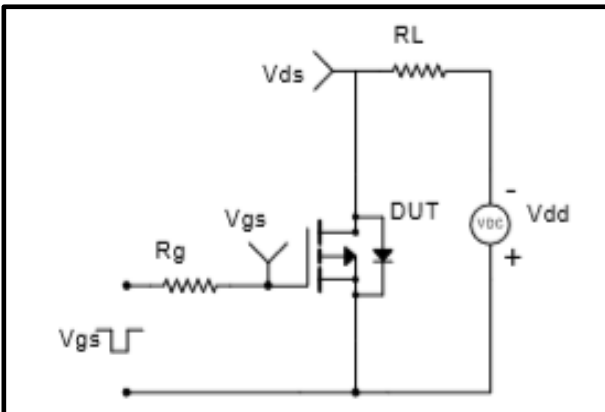

Fig.4 Gate Charge Waveform

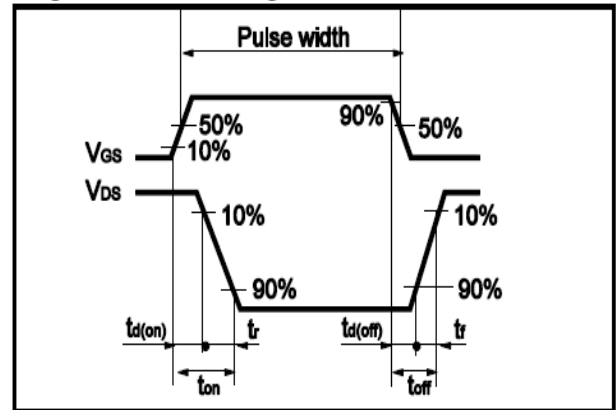

Fig.5 Avalanche Measurement Circuit

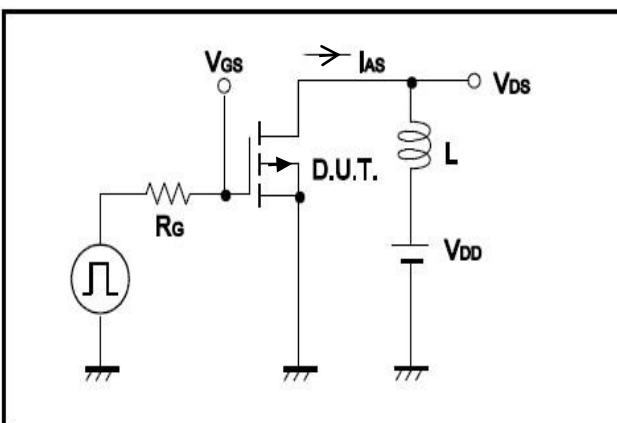
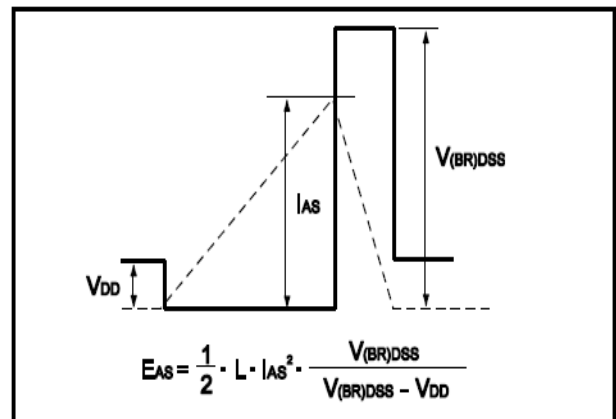
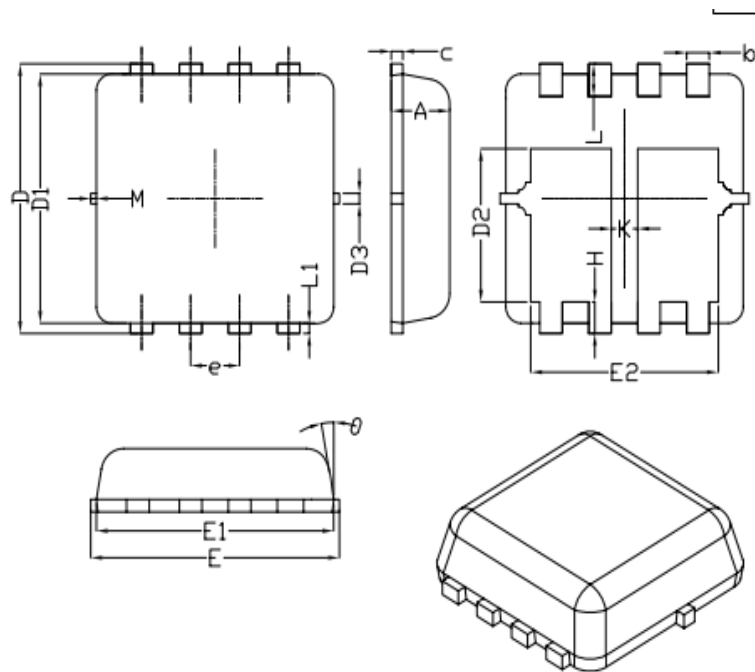

Fig.6 Avalanche Waveform



•Dimensions (DFN5×6)

Unit: mm



SYMBOL	DIMENSIONAL REQMTS		
	MIN	NOM	MAX
A	0.70	0.75	0.80
b	0.25	0.30	0.35
c	0.10	0.15	0.25
D	3.25	3.35	3.45
D1	3.00	3.10	3.20
D2	1.78	1.88	1.98
D3	---	0.13	---
E	3.20	3.30	3.40
E1	3.00	3.15	3.20
E2	2.39	2.49	2.59
e	0.65BSC		
H	0.30	0.39	0.50
L	0.30	0.40	0.50
L1	---	0.13	---
K	0.30	---	---
theta	---	10°	12°
M	*	*	0.15
* Not specified			

单击下面可查看定价，库存，交付和生命周期等信息

[>>ZMJSEMI\(真茂佳\)](#)