

• General Description

The ZM045N03N combines advanced trench MOSFET technology with a low resistance package to provide extremely low $R_{DS(ON)}$.

• Features

- Advance high cell density Trench technology
- Low $R_{DS(ON)}$ to minimize conductive loss
- Low Gate Charge for fast switching
- Low Thermal resistance

• Application

- MB/VGA Vcore
- SMPS 2nd Synchronous Rectifier
- POL application
- BLDC Motor driver

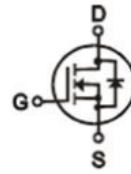
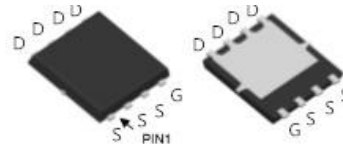
• Product Summary

 $V_{DS} = 30V$
 $R_{DS(ON)} = 4.5m\Omega$
 $I_D = 75A$

DFN5 x 6
• Ordering Information:

Part NO.	ZM045N03N
Marking	ZM045N03
Packing Information	REEL TAPE
Basic ordering unit (pcs)	3000

• Absolute Maximum Ratings ($T_C = 25^\circ C$)

Parameter	Symbol	Rating	Unit
Drain-Source Voltage	V_{DS}	30	V
Gate-Source Voltage	V_{GS}	20	V
Continuous Drain Current	$I_D @ TC=25^\circ C$	75	A
	$I_D @ TC=75^\circ C$	57	A
	$I_D @ TC=100^\circ C$	47	A
Pulsed Drain Current ①	I_{DM}	180	A
Total Power Dissipation($TC=25^\circ C$)	$P_D @ TC=25^\circ C$	80	W
Total Power Dissipation($TA=25^\circ C$)	$P_D @ TA=25^\circ C$	2.5	W
Operating Junction Temperature	T_J	-55 to 150	$^\circ C$
Storage Temperature	T_{STG}	-55 to 150	$^\circ C$
Single Pulse Avalanche Energy	E_{AS}	200	mJ

•Thermal resistance

Parameter	Symbol	Min.	Typ.	Max.	Unit
Thermal resistance, junction - case	R _{thJC}	-	-	1.6	° C/W
Thermal resistance, junction - ambient	R _{thJA}	-	-	50	° C/W
Soldering temperature, wavesoldering for 10s	T _{sold}	-	-	265	° C

•Electronic Characteristics

Parameter	Symbol	Condition	Min.	Typ	Max.	Unit
Drain-Source Breakdown Voltage	BV _{DSS}	V _{GS} =0V, I _D =250uA	30			V
Gate Threshold Voltage	V _{GS(TH)}	V _{GS} =V _{DS} , I _D =250uA	1.2		2.5	V
Drain-Source Leakage Current	I _{DSS}	V _{DS} =30V, V _{GS} =0V			1.0	uA
Gate- Source Leakage Current	I _{GSS}	V _{GS} =±20V, V _{DS} =0V			±100	nA
Static Drain-source On Resistance	R _{DS(ON)}	V _{GS} =10V, I _D =20A		4.5	6.0	mΩ
		V _{GS} =4.5V, I _D =10A		7.0	9.0	mΩ
Forward Transconductance	g _{FS}	V _{DS} =25V, I _D =10A		16		s
Source-drain voltage	V _{SD}	I _S =20A		0.8	1.28	V

•Electronic Characteristics

Parameter	Symbol	Condition	Min.	Typ	Max.	Unit
Input capacitance	C _{iss}	f = 1MHz	-	1500	-	pF
Output capacitance	C _{oss}		-	280	-	
Reverse transfer capacitance	C _{rss}		-	140	-	

•Gate Charge characteristics(T_a = 25°C)

Parameter	Symbol	Condition	Min.	Typ	Max.	Unit	
Total gate charge	Q _g	V _{DD} = 25V	-	16	-	nC	
Gate - Source charge	Q _{gs}	I _D = 8A	-	5	-		
Gate - Drain charge	Q _{gd}	V _{GS} = 10V	-	8	-		
Turn-ON Delay time	t _{D(on)}	V _{GS} =10V, V _{DS} =15V R _G =3.3Ω, I _D =15A		7.5		ns	
Turn-ON Rise time	t _r				14		ns
Turn-Off Delay time	t _{D(off)}				35		ns

Turn-Off Fall time	t_f		10	ns
--------------------	-------	--	----	----

Note: ① Pulse Test : Pulse width $\leq 300\mu s$, Duty cycle $\leq 2\%$;

Fig.1 Power Dissipation

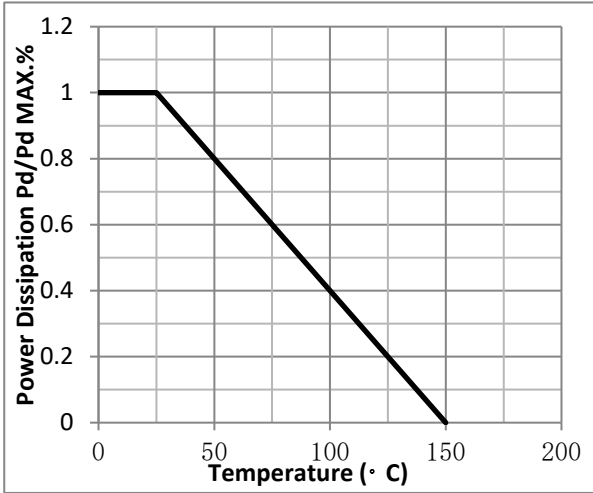

Fig.2 Typical output Characteristics

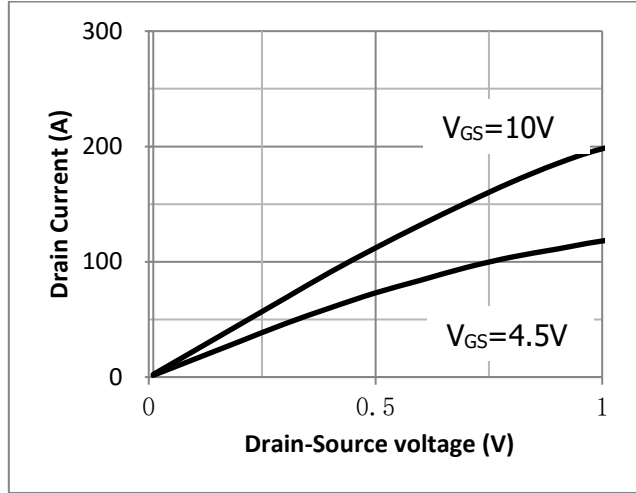

Fig.3 Threshold Voltage V.S Junction Temperature

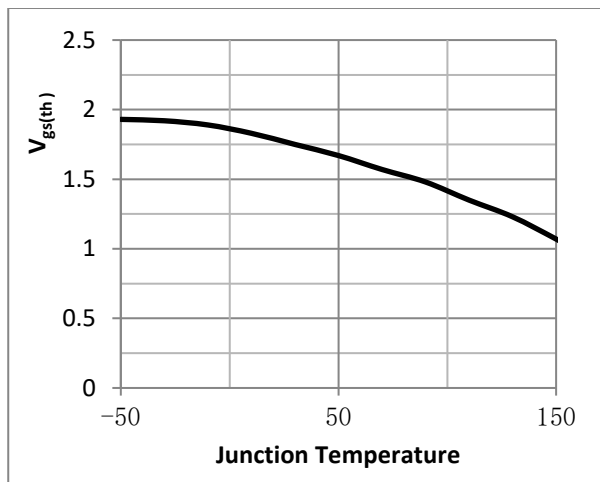

Fig.4 Resistance V.S Drain Current

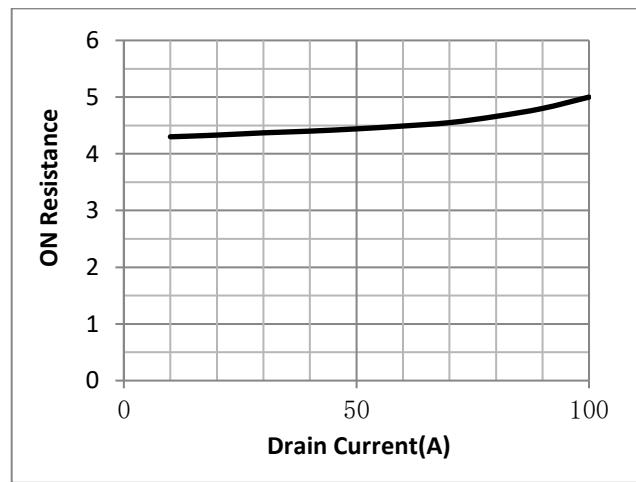

Fig.5 On-Resistance VS Gate Source Voltage

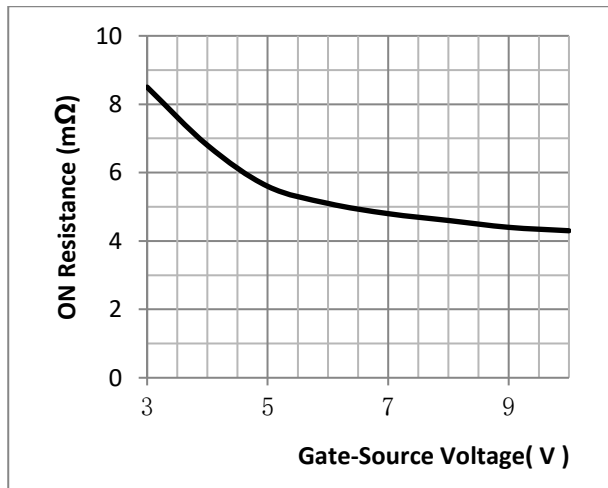

Fig.6 On-Resistance V.S Junction Temperature

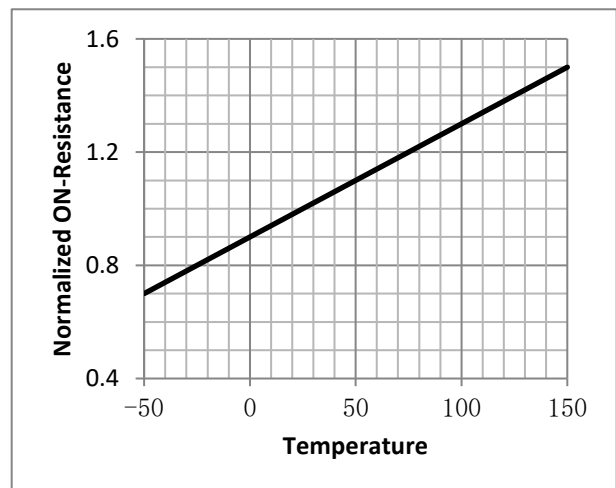

Fig.7 Switching Time Measurement Circuit

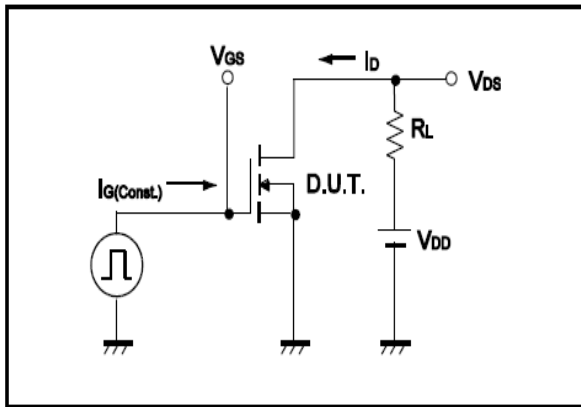

Fig.8 Gate Charge Waveform

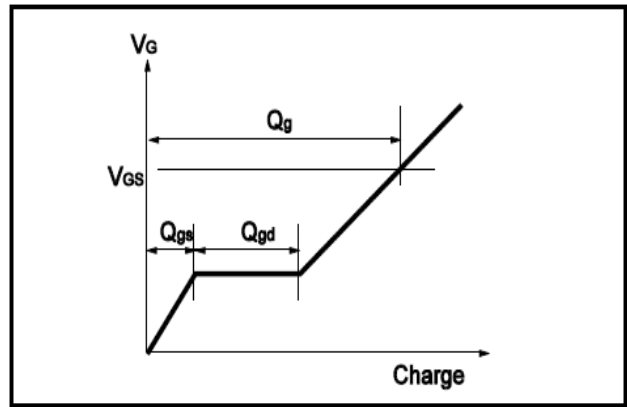

Fig.9 Switching Time Measurement Circuit

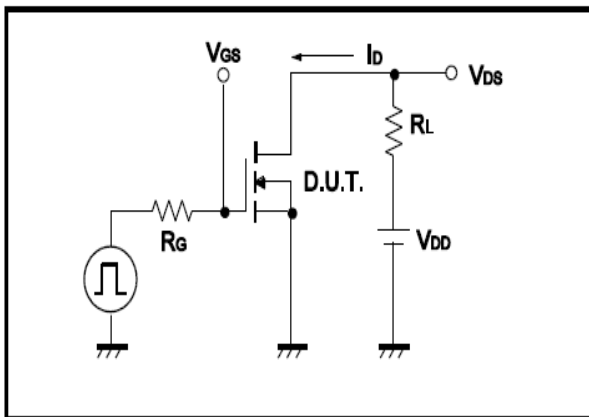

Fig.10 Gate Charge Waveform

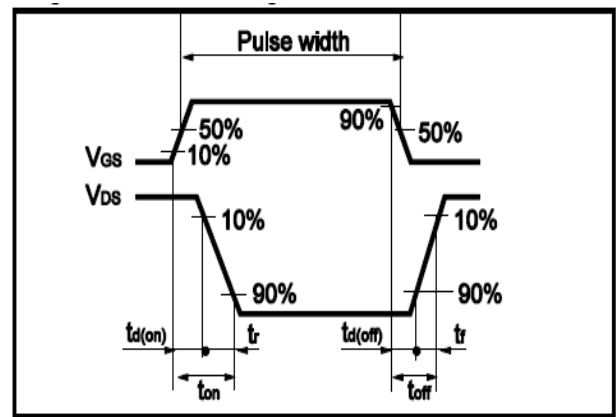

Fig.11 Avalanche Measurement Circuit

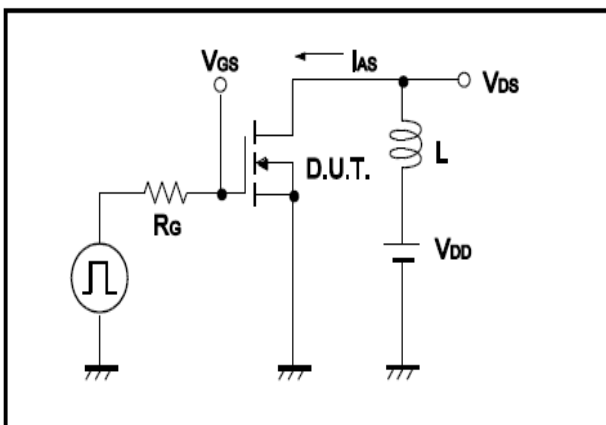
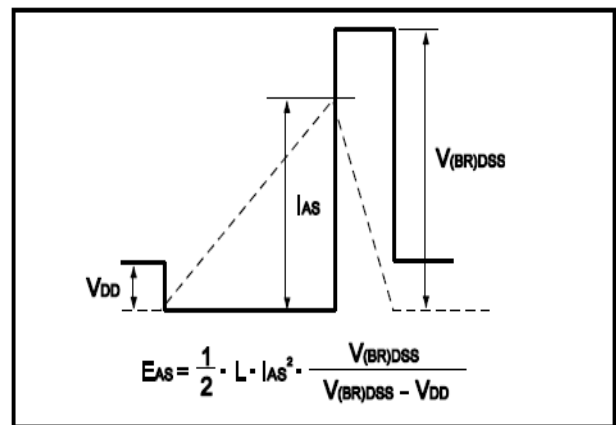
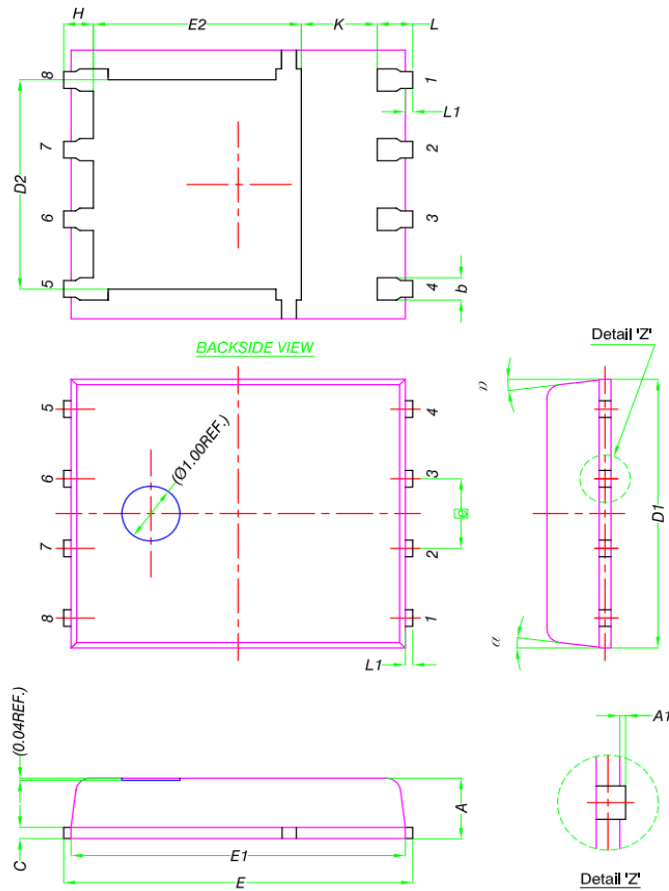

Fig.12 Avalanche Waveform



•Dimensions (DFN5x6)

Unit: mm



DIM.	MILLIMETERS		
	MIN.	NOM.	MAX.
A	0.90	1.00	1.10
A1	0	-	0.05
b	0.33	0.41	0.51
C	0.20	0.25	0.30
D1	4.80	4.90	5.00
D2	3.61	3.81	3.96
E	5.90	6.00	6.10
E1	5.70	5.75	5.80
E2	3.38	3.58	3.78
e	1.27 BSC		
H	0.41	0.51	0.61
K	1.10	-	-
L	0.51	0.61	0.71
L1	0.06	0.13	0.20
α	0°	-	12°

单击下面可查看定价，库存，交付和生命周期等信息

[>>ZMJSEMI\(真茂佳\)](#)