



**Automotive Grade Thick Film Chip Resistors
(RMF series standard)
Halogen-Free
AEC-Q200 qualified**

Document No.	TRMF-XX0S001H
Revise Date	2024/07/12
Page	1/14

1. Scope :

This specification applies for the RMF series of Automotive Grade thick film chip resistors made by TA-I.

2. Construction :

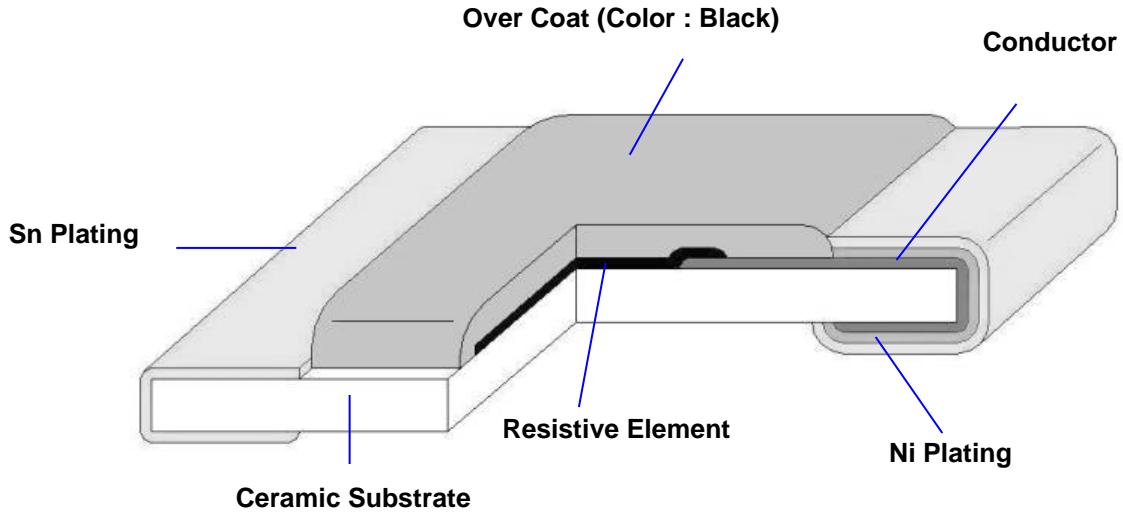

3. Type Designation :

<u>RMF</u>	<u>10</u>	<u>J</u>	<u>T</u>	<u>103</u>
Product Code	Size	Tolerance	Packaging	Nominal Resistance
RMF : Automotive Grade Chip Resistor	Power Rating			Resistance

02-0201(0603) 1/20W 04-0402(1005) 1/16W 06-0603(1608) 1/10W 10-0805(2012) 1/8W 12-1206(3216) 1/4W 13-1210(3226) 1/2W 20-2010(5025) 3/4W 25-2512(6432) 1 W	J : ±5% G : ±2% F : ±1% D : ±0.5%	T- Paper Tape E- Embossed Tape	3 digits, e.g.,: (E-24) 103 = 10kΩ 0 = 0Ω 4 digits, e.g., : (E-96) 1540 = 154Ω 43R2 = 43.2Ω
--	--	-----------------------------------	--



4. Dimensions :

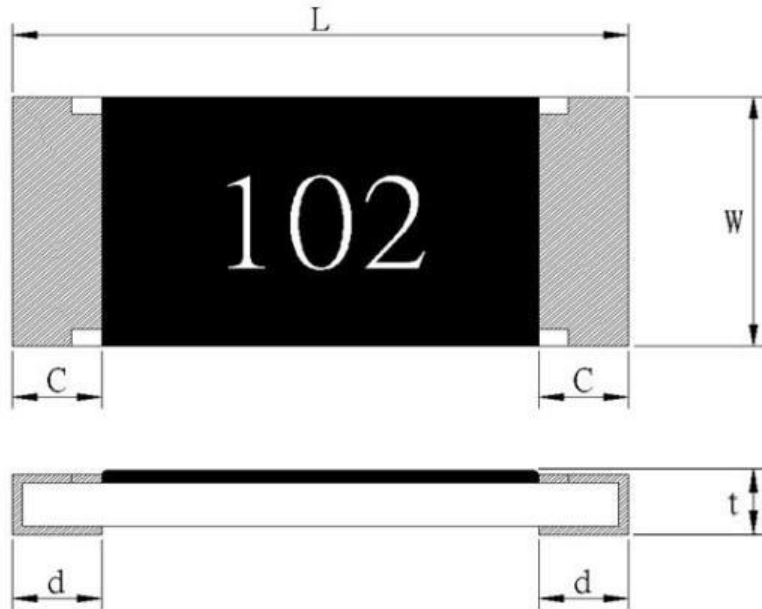

UNIT: mm

Type	L	W	C	d	t
RMF02	0.60±0.03	0.30±0.03	0.10±0.05	0.15±0.05	0.23±0.03
RMF04	$1.00^{+0.1}_{-0.05}$	0.50±0.05	0.20±0.10	0.25±0.10	0.32±0.05
RMF06	1.60±0.10	0.80±0.10	0.30±0.20	$0.30^{+0.2}_{-0.1}$	0.45±0.10
RMF10	2.00±0.10	1.25±0.10	0.40±0.20	0.40±0.20	0.50±0.10
RMF12	3.10±0.10	1.55±0.10	0.50±0.30	0.40±0.20	0.55±0.10
RMF13	3.10±0.10	2.55±0.10	0.50±0.30	0.40±0.20	0.60±0.10
RMF20	5.00±0.15	2.50±0.15	0.60±0.30	0.50±0.25	0.60±0.10
RMF25	6.30±0.20	3.20±0.20	0.60±0.30	0.50±0.25	0.60±0.10



**Automotive Grade Thick Film Chip Resistors
(RMF series standard)
Halogen-Free
AEC-Q200 qualified**

Document No.	TRMF-XX0S001H
Revise Date	2024/07/12
Page	3/14

5. Ratings & Characteristics :

Type	Power Rating at 70°C	Rating Voltage	Max. Working Voltage	Max. Over- Load Voltage	T.C.R (PPM/°C)	Resistance Range(Ω)			
						D(±0.5%) E-96&E-24	F(±1%) E-96&E-24	G(±2%) E-24	J(±5%) E-24
RMF02	1/20W	Refer 5.2	25V	50V	±200	100Ω-10KΩ	10Ω-3MΩ	10Ω-3MΩ	10Ω-10MΩ
					+600 -200		1Ω≤R<10Ω	1Ω≤R<10Ω	1Ω≤R<10Ω
RMF04	1/16W	Refer 5.2	50V	100V	±100	100Ω~1MΩ	100Ω~1MΩ	100Ω~1MΩ	100Ω~1MΩ
					±200	10Ω≤R<100Ω	10Ω≤R<100Ω	10Ω≤R<100Ω	10Ω≤R<100Ω
					+400 -200		1Ω≤R<10Ω	1Ω≤R<10Ω	1Ω≤R<10Ω
RMF06	1/10W	Refer 5.2	75V	150V	±100	10Ω-1MΩ	10Ω-1MΩ	10Ω-1MΩ	10Ω-1MΩ
					±200		1M<R≤10MΩ	1M<R≤10MΩ	1M<R≤20MΩ
					+400 -200		1Ω≤R<10Ω	1Ω≤R<10Ω	1Ω≤R<10Ω
RMF10	1/8W	Refer 5.2	150V	300V	±100	10Ω-1MΩ	10Ω-1MΩ	10Ω-1MΩ	10Ω-1MΩ
					±200		1M<R≤10MΩ	1M<R≤10MΩ	1M<R≤20MΩ
					+400 -200		1Ω≤R<10Ω	1Ω≤R<10Ω	1Ω≤R<10Ω
RMF12	1/4W	Refer 5.2	200V	400V	±100	10Ω-1MΩ	10Ω-1MΩ	10Ω-1MΩ	10Ω-1MΩ
					±200		1M<R≤10MΩ	1M<R≤10MΩ	1M<R≤20MΩ
					+400 -200		1Ω≤R<10Ω	1Ω≤R<10Ω	1Ω≤R<10Ω
RMF13	1/2W	Refer 5.2	200V	400V	±100	10Ω-1MΩ	10Ω-1MΩ	10Ω-1MΩ	10Ω-1MΩ
					±200		1M<R≤10MΩ	1M<R≤10MΩ	1M<R≤20MΩ
					+400 -200		1Ω≤R<10Ω	1Ω≤R<10Ω	1Ω≤R<10Ω
RMF20	3/4W	Refer 5.2	200V	400V	±100	10Ω-1MΩ	10Ω-1MΩ	10Ω-1MΩ	10Ω-1MΩ
					±200		1M<R≤10MΩ	1M<R≤10MΩ	1M<R≤20MΩ
					+400 -200		1Ω≤R<10Ω	1Ω≤R<10Ω	1Ω≤R<10Ω
RMF25	1W	Refer 5.2	200V	400V	±100	10Ω-1MΩ	10Ω-1MΩ	10Ω-1MΩ	10Ω-1MΩ
					±200		1M<R≤10MΩ	1M<R≤10MΩ	1M<R≤20MΩ
					+400 -200		1Ω≤R<10Ω	1Ω≤R<10Ω	1Ω≤R<10Ω

Ω THICK FILM CHIP RESISTORS

Type	Rated Current	Max Overload Current	Resistance Range
RMF02	0.5A	1A	50mΩ MAX
RMF04	1A	2.5A	50mΩ MAX
RMF06	1A	2.5A	50mΩ MAX
RMF10	2A	5A	50mΩ MAX
RMF12	2A	5A	50mΩ MAX
RMF13	2A	5A	50mΩ MAX
RMF20	2A	5A	50mΩ MAX
RMF25	2A	5A	50mΩ MAX

Operating Temp(°C): -55°C ~ +155°C

Note : Except for the above standardized products, we also provide the customized products.



5.1 Derating Curve :

For resistors operated at ambient temperature over 70°C , power rating shall be derated in accordance with figure 1.

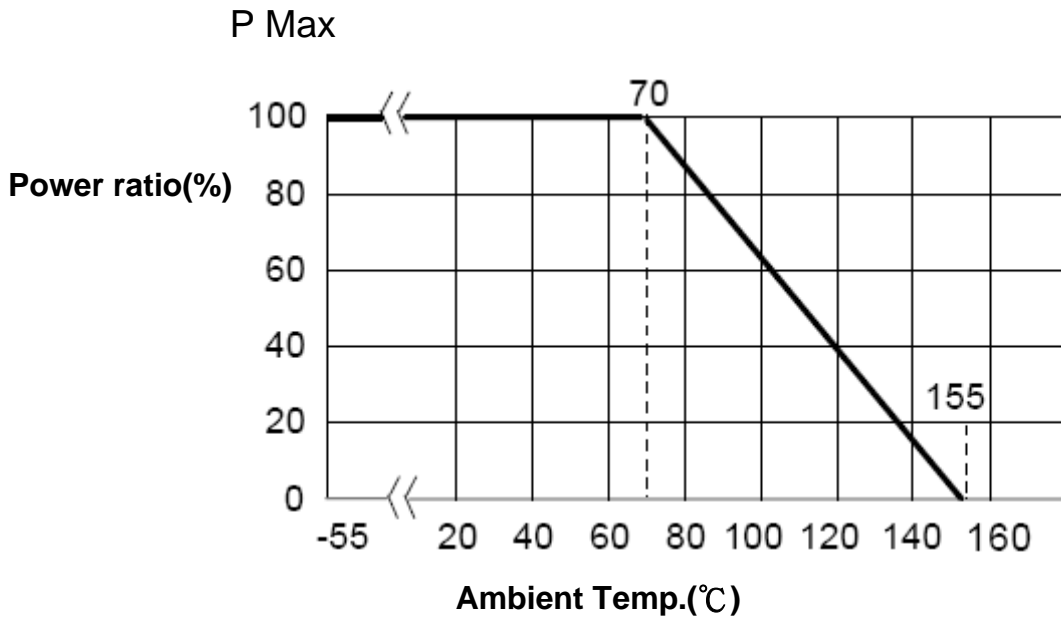

Figure 1

5.2 Rated Voltage:

The rated voltage is calculated by the following formula:

$$E = \sqrt{P * R}$$

E =Rated Voltage(V)
 P =Rated Power(W)
 R =Resistance Value(Ω)

E.G. : What is RMF06JT102 the rated voltage ?

RMF06JT102 P:1/10W ; R:102 = 1K Ω = 1000 Ω

$$E = \sqrt{0.1(W) * 1000(\Omega)} = 10 (V)$$



**Automotive Grade Thick Film Chip Resistors
(RMF series standard)
Halogen-Free
AEC-Q200 qualified**

Document No.	TRMF-XX0S001H
Revise Date	2024/07/12
Page	5/14

6. Reliability Tests:

Test Items	Reference standard	Condition of Test	Test Limits ΔR
Temperature Coefficient of Resistance	IEC 60115-1 4.8	-At +25/-55 °C and +25/+125 °C	Refer 5.0
Short Time Overload	IEC60115-1 4.13	2.5 X rated voltage for 5 sec	$\pm(1\% + 0.05\Omega)$ Remarks : 0201 : $\pm(2\% + 0.1\Omega)$ 0 Ω : 50m Ω or less
High Temperature Exposure (Storage)	AEC-Q200-REV D-Test 3 MIL-STD-202 Method 108	1000 hrs. @ T=125°C. Unpowered. Measurement at 24 \pm 2 hours after test conclusion.	0.5%,1% : $\pm(1.0\%+0.05\Omega)$ 2%,5% : $\pm(2.0\%+0.1\Omega)$ 0201 : $\pm(3\% + 0.1\Omega)$ 0 Ω : 50m Ω or less
Temperature Cycling	AEC-Q200-REV D-Test 4 JESD22 Method JA-104	1000 Cycles (-55°C to+125°C) Measurement at 24 \pm 4 hours after test conclusion. 30min maximum dwell time at each temperature extreme. 1 min. maximum transition time.	$\pm(1\% + 0.05\Omega)$ 0201 : $\pm(2\% + 0.1\Omega)$ 0 Ω : 50m Ω or less
Moisture Resistance	AEC-Q200-REV D-Test 6 MIL-STD-202 Method 106	T=24 hours / Cycle, 10 Cycles. Notes: Steps 7a & 7b not required. Unpowered .	0.5%,1% : $\pm(1.0\%+0.05\Omega)$ 2%,5% : $\pm(2.0\%+0.1\Omega)$ 0201 : $\pm(3\% + 0.1\Omega)$ 0 Ω : 50m Ω or less
Biased Humidity	AEC-Q200-REV D-Test 7 MIL-STD-202 Method 103	1000 hours 85°C/85%RH. Note: Specified conditions: 10% of operating power(not exceeding max working voltage). Measurement at 24 \pm 2 hours after test conclusion.	$\pm(3\% + 0.1\Omega)$ 0201 : $\pm(5\% + 0.1\Omega)$ 0 Ω : 100m Ω or less
Operational Life	AEC-Q200-REV D-Test 8 MIL-STD-202 Method 108	1000 hours TA=125°C at 35% rated power. Measurement at 24 \pm 4 hours after test conclusion.	0.5%,1% : $\pm(1\% + 0.05\Omega)$ 2%,5% : $\pm(3\% + 0.1\Omega)$ 0201 : $\pm(5\% + 0.1\Omega)$ 0 Ω : 100m Ω or less
External Visual	AEC-Q200-REV D-Test 9 MIL-STD-883 Method 2009	Electrical test not required. Inspect device construction, marking and workmanship.	
Physical Dimension	AEC-Q200-REV D-Test 10 JESD22 Method JB-100	Verify physical dimensions to the applicable device detail specification. Note: User(s) and Suppliers spec. Electrical test not required.	
Resistance to Solvents	AEC-Q200-REV D-Test 12 MIL-STD-202 Method 215	a:Isopropyl Alcohol : Mineral Spirits= 1 : 3 b:Terpene Defluxer c:Deionized water : Propylene Glycol Monomethyl Ether : monoethanolamine = 42 : 1 : 1	Marking and protective layer can not be detached
Mechanical Shock	AEC-Q200-REV D-Test 13 MIL-STD-202 Method 213	Wave Form : Tolerance for half sine shock pluse. Peak value is 100g's. Normal duration(D) is 6(ms)	$\pm(1\% + 0.05\Omega)$ 0 Ω : 50m Ω or less
Vibration	AEC-Q200-REV D-Test 14 MIL-STD-202 Method 204	5 g's for 20 min., 12 cycles each of 3 orientations. Note: Test from 10-2000 Hz.	$\pm(1\% + 0.05\Omega)$ 0 Ω : 50m Ω or less
Resistance to Soldering Heat	AEC-Q200-REV D-Test 15 MIL-STD-202 Method 210	Condition B : Immerse the specimens in and eutectic solder at 260 \pm 5°C for 10 \pm 1S .	0.5%,1% : $\pm(0.5\% + 0.05\Omega)$ 2%,5% : $\pm(1\% + 0.05\Omega)$ 0201 : $\pm(2\% + 0.1\Omega)$ 0 Ω : 50m Ω or less



**Automotive Grade Thick Film Chip Resistors
(RMF series standard)
Halogen-Free
AEC-Q200 qualified**

Document No.	TRMF-XX0S001H
Revise Date	2024/07/12
Page	6/14

Thermal Shock	AEC-Q200-REV D-Test 16 MIL-STD-202 Method 107	-55°C/+155°C. Note: Number of cycles required-300, Maximum transfer time-20 seconds, Dwell time-15 minutes. Air-Air.	±(1% + 0.05Ω) 0201 : ±(2% + 0.1Ω) 0Ω : 50mΩ or less
ESD	AEC-Q200-REV D-Test 17	verify the voltage setting at 500V	±(1% + 0.05Ω) 0201 : ±(2% + 0.1Ω)
Solderability	AEC-Q200-REV D-Test 18 J-STD-002	Method B, aging 4 hours at 155 °C dry heat Lead-free solder bath at 235±3 °C Dipping time: 3±0.5 seconds	> 95% area covered with tin
Flammability	AEC-Q200-REV D-Test 20 UL-94	V-0 or V-1 are acceptable. Electrical test not required.	V-0 or V-1
Board Flex (Bending)	AEC-Q200-REV D-Test 21	3mm deflection (RMF02~RMF13) 2mm deflection (RMF20~RMF25)	0.5%,1% : ±(0.5% + 0.05Ω) 2%,5% : ±(1% + 0.05Ω) 0201 : ±(1% + 0.05Ω) 0Ω : 50mΩ or less
Terminal Strength (SMD)	IEC 60115-1 4.32	Force of 1.02kg for 10±1 seconds. Remarks : RMF02 : NA , RMF04 : 0.51kg	±(0.5% + 0.05Ω) 0Ω : 50mΩ or less
Sulfuration Test	ASTM-B-809-95	Sulfur (saturated vapor) 360 hours,105±2°C, unpowered	0.5%,1% : ±(1%+0.05Ω) 2%, 5% : ±(2%+0.1Ω) 0Ω : 100mΩ or less

Note* : RCWV : Rated continuous working voltage .

7. Marking

7.1 ±2% & ±5%(E24) : RMF06 / RMF10 / RMF12 / RMF13 / RMF20 / RMF25

Resistance value is expressed by 3 digits, the first two digits represent the significant figures of nominal resistance value in Ω, and the third digit represents exponent for base of 10.

E.G. :, 102 = 10×10² = 1000Ω = 1KΩ





**Automotive Grade Thick Film Chip Resistors
(RMF series standard)
Halogen-Free
AEC-Q200 qualified**

Document No.	TRMF-XX0S001H
Revise Date	2024/07/12
Page	7/14

7.2 ±0.5% , ±1% (E96) : RMF10 / RMF12 / RMF13 / RMF20 / RMF25

Resistance value is expressed by 4 digits , the first three digits represent the significant figures of nominal resistance value in Ω , and the fourth digit represents exponent for base of 10.

E.G. : 1000 = $100 \times 10^0 = 100 \Omega$



7.3 ±0.5% , ±1% (E96): RMF06

When the marking space is too small in such small-sized resistors as RMF06, the marking can not made by 4 digits and may be made by two digits combined with one English capital.

Symbol for E96 series nominal resistance value

Symbol	E96	Symbol	E96	Symbol	E96	Symbol	E96
01	100	25	178	49	316	73	562
02	102	26	182	50	324	74	576
03	105	27	187	51	332	75	590
04	107	28	191	52	340	76	604
05	110	29	196	53	348	77	619
06	113	30	200	54	357	78	634
07	115	31	205	55	365	79	649
08	118	32	210	56	374	80	665
09	121	33	215	57	383	81	681
10	124	34	221	58	392	82	698
11	127	35	226	59	402	83	715
12	130	36	232	60	412	84	732
13	133	37	237	61	422	85	750
14	137	38	243	62	432	86	768
15	140	39	249	63	442	87	787
16	143	40	255	64	453	88	806
17	147	41	261	65	464	89	825
18	150	42	267	66	475	90	845
19	154	43	274	67	487	91	866
20	158	44	280	68	499	92	887
21	162	45	287	69	511	93	909
22	165	46	294	70	523	94	931
23	169	47	301	71	536	95	953
24	174	48	309	72	549	96	976



**Automotive Grade Thick Film Chip Resistors
(RMF series standard)
Halogen-Free
AEC-Q200 qualified**

Document No.	TRMF-XX0S001H
Revise Date	2024/07/12
Page	8/14

Symbol for multipliers

Symbol	A	B	C	D	E	F	G	H	X	Y	Z
multipliers	10 ⁰	10 ¹	10 ²	10 ³	10 ⁴	10 ⁵	10 ⁶	10 ⁷	10 ⁻¹	10 ⁻²	10 ⁻³

E.G : 01A = 100×10⁰ = 100Ω



Notes :

When the resistance value is not in the list of E96 , 3 digitals with underline in E-24 series is used as mark .

E.G. : 0603 , 120Ω , 1% Marking is 121



7.4 ±0.5% ,±1%(E96/3digitals)

The resistance value by 3 digitals is requirement for customer.

7.5 RMF06 : R represents the 「 · 」

7.6 RMF02 & RMF04





**Automotive Grade Thick Film Chip Resistors
(RMF series standard)
Halogen-Free
AEC-Q200 qualified**

Document No.	TRMF-XX0S001H
Revise Date	2024/07/12
Page	9/14

8. Taping & Reel :

8.1 Taping Dimensions

8.1.1 4 mm pitch paper :

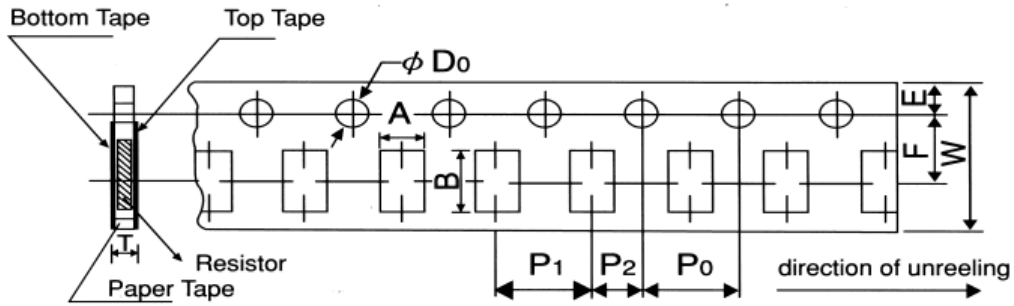

Packing	Type	A	B	W	F	E	P ₁	P ₂	P ₀	D ₀	T	
Paper	RMF06	1.1±0.1	1.9±0.1	8.0±0.2	3.5±0.05	1.75±0.1	4.0±0.1	2.0±0.05	4.0±0.1	φ 1.5	0.64±0.1	
	RMF10	1.6±0.15	2.4±0.2								+0.1	
	RMF12	2.0±0.15	3.6±0.2								-0	0.84±0.1
	RMF13	2.8±0.2	3.6±0.2									

8.1.2 2 mm pitch paper :

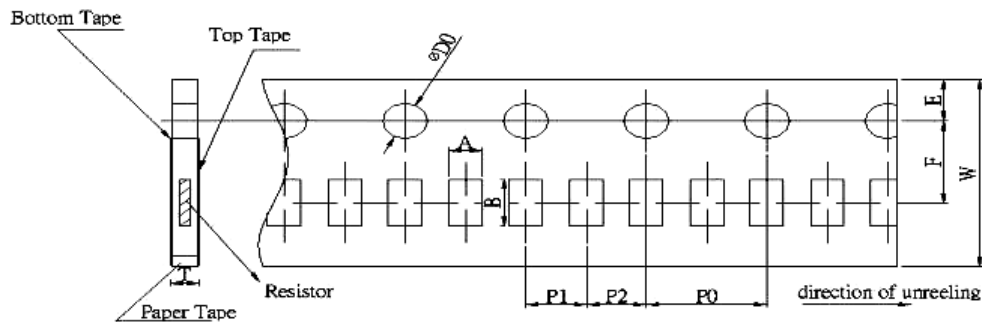

Packing	Type	A	B	W	F	E	P ₁	P ₂	P ₀	D ₀	T
Paper	RMF02	0.37±0.05	0.67±0.1	8.0±0.2	3.5±0.05	1.75±0.1	2.0±0.05	2.0±0.05	4.0±0.1	φ 1.5	0.37±0.1
	RMF04	0.7±0.05	1.2±0.05				2.0±0.1	2.0±0.1			-0



**Automotive Grade Thick Film Chip Resistors
(RMF series standard)
Halogen-Free
AEC-Q200 qualified**

Document No.	TRMF-XX0S001H
Revise Date	2024/07/12
Page	10/14

8.1.3 4 mm pitch Emboss :

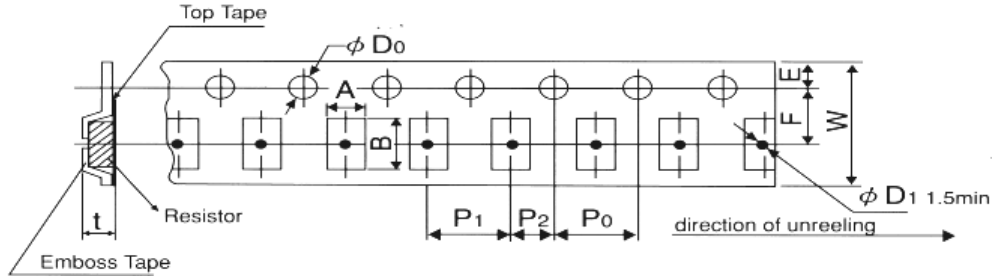

UNIT: mm

Packing	Type	A	B	W	F	E	P ₁	P ₂	P ₀	D ₀	T
Emboss	RMF20	2.8±0.2	5.3±0.2	12.0±0.2	5.5±0.05	1.75±0.1	4.0±0.1	2.0±0.05	4.0±0.05	φ 1.5	0.85±0.15
	RMF25	3.6±0.2	6.9±0.2								

UNIT: pcs

Type	Package Size	Paper Tape				Emboss Plastic Tape 4 mm pitch
		4 mm pitch		2 mm pitch		
		178mm/R	330mm/R	178mm/R	330mm/R	
RMF	02			10000		
RMF	04			10000	20000	
RMF	06	5000	10000			
RMF	10	5000	10000			
RMF	12	5000	10000			
RMF	13	5000				
RMF	20					4000
RMF	25					4000



8.2 Reel Specifications:

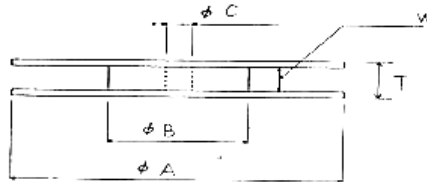
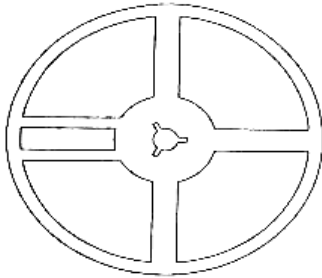

UNIT: mm

Type	ϕA	ϕB	ϕC	W	T
RMF02 / 04 / 06 RMF10 / 12 / 13	178.0 ± 2.0	60.0 ± 1.0	13.0 ± 1.0	9.0 ± 1.0	11.5 ± 1.0
RMF20 / 25				13.0 ± 1.0	15.5 ± 1.0

8.3. Peel –off force :

Peel –off force of paper and blister tape is in accordance with “JIS-C5202 ”
that is , 0.1 to 0.7 N at a peel-off speed of 300 mm / minute.

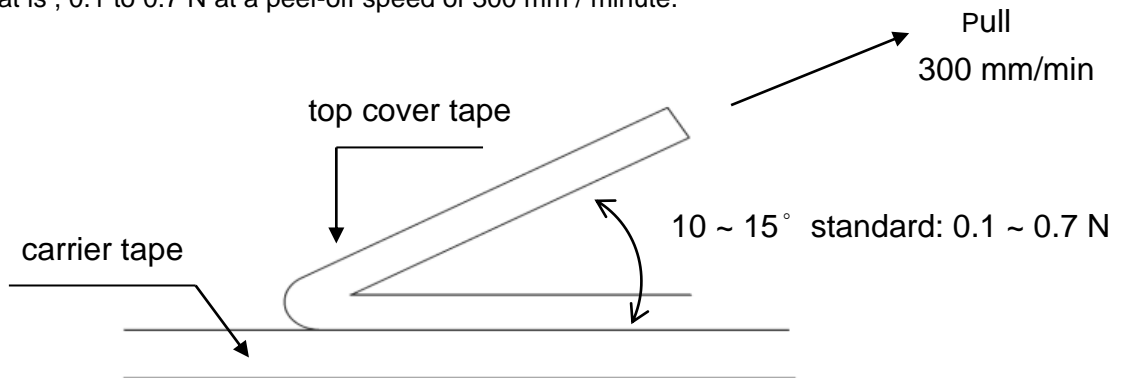



9. Recommended land patterns :

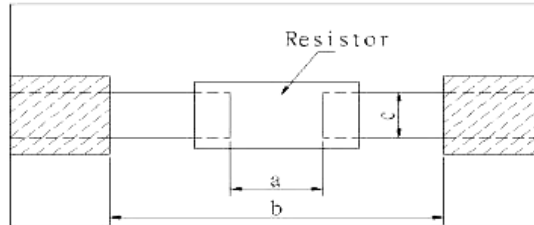

Land pattern		Dimension (mm)		
		a	b	c
Type	Size			
RMF	02 (0201)	0.25~0.3	0.7~0.9	0.3~0.4
RMF	04 (0402)	0.50~0.6	1.4~1.6	0.4~0.6
RMF	06 (0603)	0.7~0.9	2.0~2.2	0.8~1.0
RMF	10 (0805)	1.0~1.4	3.2~3.8	0.9~1.4
RMF	12 (1206)	2.0~2.4	4.4~5.0	1.2~1.8
RMF	13 (1210)	2.0~2.4	4.4~5.0	2.3~3.5
RMF	20 (2010)	3.3~3.7	5.7~6.5	2.3~3.5
RMF	25 (2512)	3.6~4.0	7.6~8.6	2.3~3.5

10. Recommend IR – Reflow profile : (solder : Sn96.5 / Ag3 / Cu0.5)

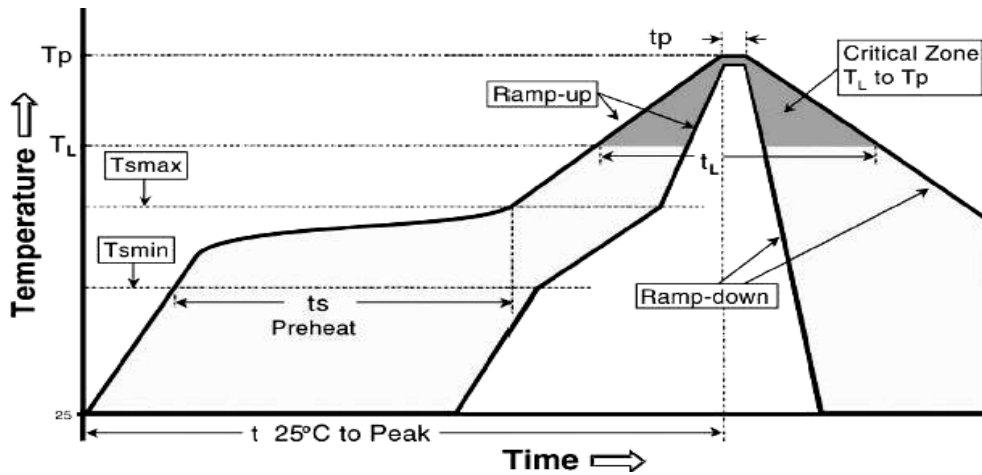

Profile Feature	Lead (Pb)-Free Assembly
Average ramp-up rate (T _{max} to T _p)	3°C / second max.
Preheat - Temperature Min (T _{min}) - Temperature Max (T _{max}) - Time (T _{min} to T _{max}) (ts)	150°C 200°C 60 -120 seconds



**Automotive Grade Thick Film Chip Resistors
(RMF series standard)
Halogen-Free
AEC-Q200 qualified**

Document No.	TRMF-XX0S001H
Revise Date	2024/07/12
Page	13/14

Time maintained above : - Temperature (T _L) - Time (T _L)	217°C 60-150 seconds
Peak Temperature (T _p)	260°C
Time within $\begin{matrix} +0 \\ -5 \end{matrix}$ °C of actual Peak Temperature (t _p) ²	10 seconds
Ramp-down Rate	6°C/second max.
Time 25°C to Peak Temperature	8mimutes max.

Remark : To avoid discoloration phenomena of chip on terminal electrodes,
please use N2 Re-flow furnace.

11. Storage Conditions

Temperature: 5°C~35°C ,Humidity:40%~75%

12. Shelf Life

2 years from manufacturing date.

13. ECN

Engineering Change Notice: The customer will be informed with ECN if there is significant modification on the characteristics and materials described in Approval Sheet.



**Automotive Grade Thick Film Chip Resistors
(RMF series standard)
Halogen-Free
AEC-Q200 qualified**

Document No.	TRMF-XX0S001H
Revise Date	2024/07/12
Page	14/14

14. Manufacturing Country & City

TA-I TECHNOLOGY CO., LTD. (Taiwan– Tao Yuan)

Tel : (+886) 3-3246169 Fax : (+886) 3-3246167

Associated companies :

(1) TA-I TECHNOLOGY (SU ZHOU) CO., LTD. (China – Su Zhou)

Tel : (+86) 512-63457879 Fax : (+86) 512-63457869

(2) TA-I TECHNOLOGY ELECTRONIC (DONGGUAN) CO., LTD. (China –Dongguan)

Tel : (+86) 769-8339-4790~3 Fax : (+86) 769-8339-4794

(3) FORTUNE TASK ENTERPRISES LIMITED.(China – Dongguan)

Tel : (+86) 769-8339-4790~3 Fax : (+86) 769-8339-4794

(4) TAI OHM ELECTRONICS (M) SDN. BHD. (Malaysia – Penang)

Tel : (+60) 4- 3900480 Fax : (+60) 4-3901481

单击下面可查看定价，库存，交付和生命周期等信息

[>>TA-I\(大毅\)](#)